

HeadCell® vs. Mechanically Induced Vortex (MIV) Grit Separation Systems

Using engineering principles to evaluate grit system design & performance.

Comparing performance of vortex grit removal systems can be a challenging task. Owners and engineers are forced to navigate a field of, what can be conflicting, performance claims made by various equipment manufacturers, using differing testing methods making these claims difficult to verify. This is especially true at a time when the authenticity of virtually all information can be questioned depending on the source and the intended reader. Comparisons based on features/benefits are also challenging as designs differ significantly, yet the basic principles of vortex flow and sedimentation apply to all technologies. Fortunately, proven engineering principles can be used to sift through the information and yield a truthful and accurate evaluation.

Benefits of Vortex Separation

All vortex type separators offer several benefits when compared to other liquid/solid separation processes. Vortex flow is used to minimize short circuiting, extend particle residence time, and sweep solids to a central location for collection.

Mathematical Principles of Vortex Separation

Forced vortex grit separators (Stacked Tray & Mechanically Induced Vortex) have a relatively low energy (headloss) requirement and have commonality in that gravitational forces exceed centrifugal forces exerted on the particles being removed as shown below in Fig. 1. If gravitational forces exceed centrifugal forces ($F_g > F_c$) then gravity governs the separation process and basic sedimentation principles apply. Systems of this type can be evaluated in the context of Stokes Law where particle settling velocity and surface overflow rate are key factors in determining vortex separator sizing and particle capture efficiency.

The efficiency of a theoretical grit separator or settling tank is expressed as the ratio of the settling velocity (V_s) of the particles to be removed to the surface overflow rate (V_o), i.e. V_s/V_o . The surface overflow rate is defined as the ratio of flow (Q) to be treated in a grit separator or settling tank to the plan area (A) of the chamber or tank, i.e. $V_o = Q/A$. Grit particles settle as discrete particles (WEF, et. al, 2017) where settling is unhindered with an independent settling velocity. Based on these well-established engineering principles summarized in Fig. 2 below, to capture a discrete sphere of silica sand that is 106 micron with 2.65 S.G. which settles at 0.99 cm/sec ($V_s = 0.99$ cm/sec) a surface overflow rate of 21,024 gpd/ft² or 14.6 gpm/ft² is required.

3rd Party Technical Papers Verify Grit Basin Sizing & Design Considerations

The claim that grit particle settling velocity and surface overflow rate do not apply to mechanically induced vortex grit separators conflicts with basic sedimentation principles and has been contradicted in papers published by independent parties in the consulting engineering and plant operations communities. One example is the 2012 WEFTEC paper (Pretorius, 2012) in which Coenraad Pretorius of Carollo Engineers reviewed traditional sizing criteria used for vortex grit basins and concluded the following:

- Use Surface Overflow Rate (SOR) as a basis of design. It is more conservative than using Froude number similarity. Design SOR can easily be adjusted for site-specific grit properties.
- Equation 6 and an assumed value for α can be used to determine ϕ . Alternatively, a value of ϕ can be assumed and used to determine $SOR = up/\phi$.
- Determine the target removal efficiency for a single grit particle size. For example, in plants with primary clarifiers, lower grit removal efficiency may be tolerated, as long as the impact is quantified and determined to be acceptable.
- Expect to capture a significant quantity of organic solids. The grit handling system should be designed to deal with this.
- Determine the peak grit load. Within reason, grit handling equipment must be sized for this load.

Product	F_c / F_g	Footprint	Energy Needs
Mechanically Induced Vortex (MIV)	<0.5	Large	Low
HeadCell® (Stacked Tray)	<2	Large	Low
Grit King® (Structured Flow)	1-10	Large	Low
SlurryCup™ & TeaCup® (Free Vortex)	10-40	Medium	Medium
Hydrocyclone (Centrifuge)	>500	Small	High

Fig.1 Characteristics of Various Grit Removal Systems

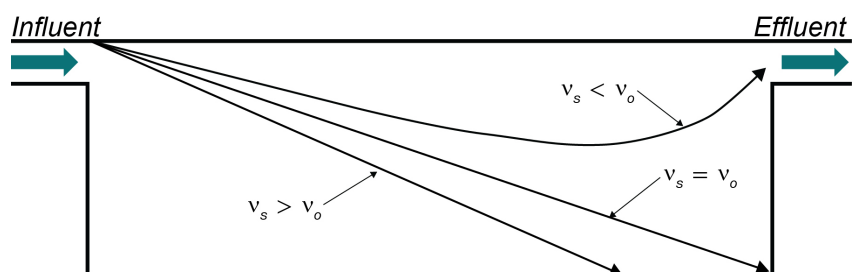

Fig. 2 Settling Velocity & Surface Overflow Rate

Debunking a Baffling Performance Claim

The use of baffles in MIV separators has been introduced in an effort to improve capture efficiency. In the case of one manufacturer, claims of achieving 95% removal of grit ≥ 105 micron is attributed to the addition of baffles. This concept was evaluated at Hampton Roads Sanitation District (HRSD) and a review of their findings was published at WEFTEC (McNamara, 2012). HRSD plant staff conducted extensive CFD analysis of more than 10 different baffle designs and conducted dye studies on those considered to have the best potential. Below is an overview of their findings:

- The CFD simulation model of the grit vortex matched field data and observations, so that it could be used for design improvement investigation.
- The grit vortex investigated in this project has hydraulic short circuiting.
- The grit vortex collection efficiency decreased with increasing hydraulic flow.
- The grit vortex unit was fairly efficient for collecting grit particles over 400 μm in size.
- The grit vortex unit was inefficient for capturing grit particles under 300 μm in size.
- The grit vortex collection efficiency decreased with decreasing grit SG.
- The vortex mechanism is not the principal component for grit removal.
- Type 1 discrete particle settling velocity is the primary component for grit removal; therefore, surface overflow rate is critical for grit efficiency.
- Removing the grit vortex impeller had no impact according to the CFD model.
- Of the baffle arrangements investigated, only Baffle 10 showed improved collection efficiency, and this improvement was minimal.

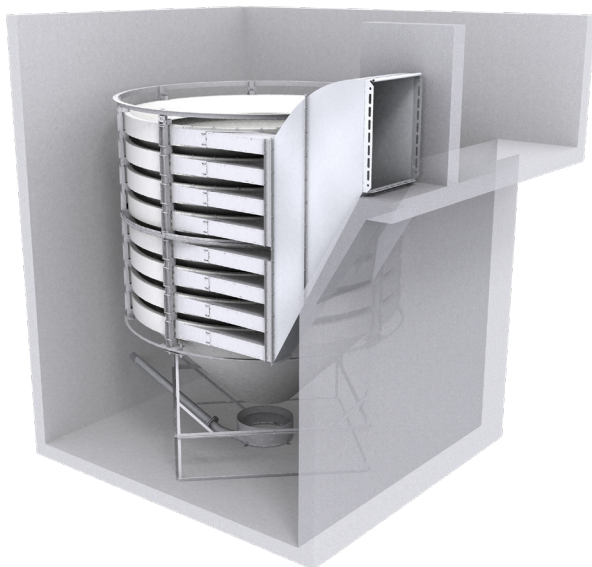

Fig. 4 HeadCell® Advanced Grit Separation System

Conclusions

In summary, when gravitational forces exceed centrifugal forces in vortex grit separators, (i.e. it is a low energy or low headloss device) then gravity governs the separation process and surface overflow rate is the key design criteria. Baffling can be used to increase residence time and reduce short circuiting in vortex separators, however, in practice improvements due to baffling are minimal. At the time of this writing, there is no independent testing to support claims of 95% removal of grit ≥ 105 micron when surface overflow rate exceeds 21,024 gpd/ft² or 14.6 gpm/ft² with or without the use of baffles in an MIV.

The table below (Fig. 3) provides an overview of the surface overflow rate in various diameter MIV systems. One MIV manufacturer has published an equation in an attempt to explain an alternative principal of operation. This equation has been reviewed by independent parties and found to contain inaccuracies. For more information on this equation contact Hydro International.

Flow Capacity	Chamber Diameter	Chamber Area	Detention Time	Overflow Rate
MGD	(ft.)	(ft ²)	(sec.)	(gpm/ft ²)
1	6	28.3	67	24.6
2.5	7	38.5	45	45.1
4	8	50.2	38	55.3
7	10	78.5	36	61.9
12	12	113.0	41	73.7
20	16	201.0	49	69.1
30	18	254.3	50	81.9
50	20	314.0	47	110.5
70	24	452.0	53	107.9
100	32	804.2	66	86.7

Fig. 3 Mechanically Induced Vortex Surface Overflow Rate

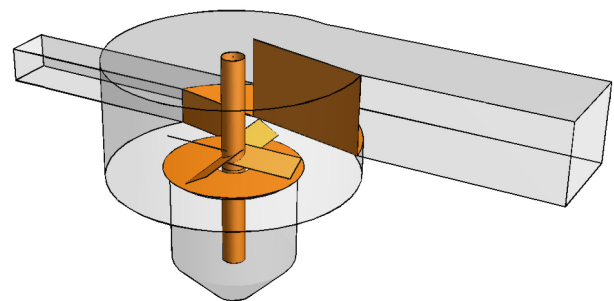

Fig. 5 Mechanically Induced Vortex Grit System

References

- WEF, et. al. (2017) Guidelines for Grit Sampling and Characterization. Alexandria, VA: Water Environment Federation.
- Pretorius, C. (2012) A Review of Vortex Grit Basin Design. Proceedings of the Water Environment Federation (WEF). Alexandria, VA. WEF.
- McNamara, B. et. al. (2012) How to Baffle a Vortex. Proceedings of the Water Environment Federation (WEF). Alexandria, VA. WEF.

Learn more

To learn more about how the HeadCell® can improve your plant, visit hydro-int.com, or contact us:

Americas

1 (866) 615 8130
questions@hydro-int.com

Asia Pacific

+61 436 433 686
enquiries@hydro-int.com

Europe & RoW

+44 (0)1275 878371
enquiries@hydro-int.com

Middle East

+971 506 026 400
enquiries@hydro-int.com