

TurboStar[®]

Directional Mixer



AQUA-AEROBIC SYSTEMS, INC.
A Metawater Company

TurboStar®

Directional Mixer

The TurboStar® directional mixer is used in municipal and industrial wastewater applications to introduce directional linear mixing into lagoons, equalization basins, sludge holding and/or activated sludge systems. The unit provides thorough circulation and mixing of basin contents. It is excellent for shallow depths and channels. TurboStar is an ideal solution for upgrading, retrofitting, supplementing, or replacing under-performing mixer technologies.

Features and Specifications

- Robust materials of construction, consisting of 304 stainless steel and hot-dipped galvanized steel
- Self-cleaning propeller ensures consistent high performance
- Engineered three-bladed spiral propeller for maximum efficiency
- Durable pontoons with galvanized framework
- Robust design for easy installation
- No submerged seals or bearings
- Available in 3 - 30 HP (2.2 - 22 kW)
- Float and bridge mounting options for flexible installation in any basin



TurboStar® in Operation

How it Works

The TurboStar mixes and circulates by rotating a three-blade helical propeller. Ideal for anywhere directional mixing is needed. Only 3 moving parts to make for easier maintenance.

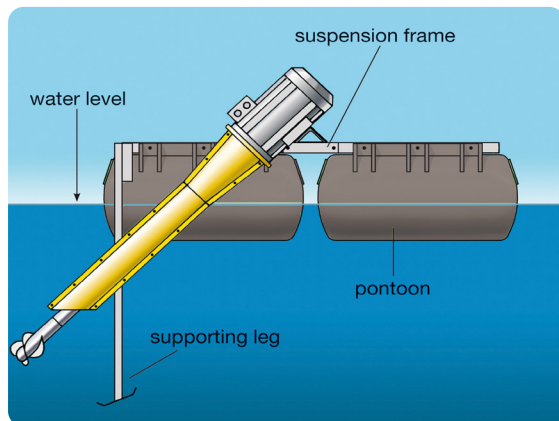

Mechanisms of Mixing

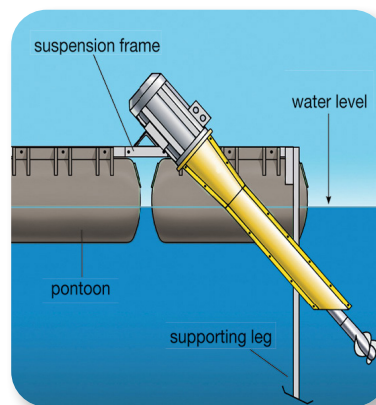

Flotation Mount

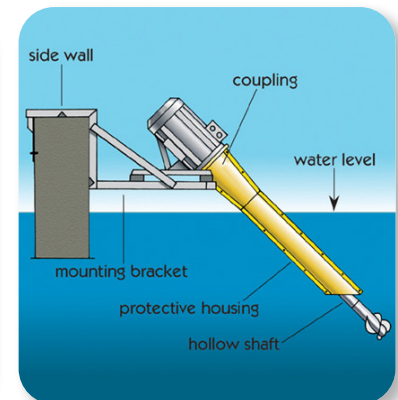

Wall Mount

Benefits

- Negligible noise level
- Nearly universal installation into any basin
- Can be installed without dewatering or taking a basin offline
- Minimal maintenance
- No underwater parts to maintain



AQUA-AEROBIC SYSTEMS, INC.
A Metawater Company

www.aqua-aerobic.com

6306 N. Alpine Road, Loves Park, IL 61111-7655
p 815.654.2501 | f 815.654.2508 | solutions@aquaaerobic.com