

TREATMENT PLANT OPERATOR

# tpo™

DEDICATED TO WASTEWATER & WATER TREATMENT PROFESSIONALS

tpomag.com  
MAY 2017

**IN MY WORDS:**  
**Directions in water research**  
PAGE 42

## The Old and *the New*

**JUMPING BROOK PLANT  
TUBE SETTLERS  
DRIVE DOWN TURBIDITY**  
PAGE 38

Matt Walsh  
Production Supervisor  
Neptune Township, N.J.

**HOW WE DO IT:**  
**Converting to  
hypochlorite disinfection**  
PAGE 20

**TECH TALK:**  
**Applying vibration analysis**  
PAGE 30





See Us at  
**ACE17**  
June 11-14  
**BOOTH**  
2449

# ProSeries-M<sup>®</sup>

## PRECISION CHEMICAL METERING

— FOR THE TREATMENT OF MUNICIPAL WATER & WASTEWATER. —

**Now Shipping!**

**HYBRID DIAPHRAGM  
METERING PUMP**

**ProSeries-M<sup>®</sup>**  
**MD-3**



**MD-3 DELIVERS A NEW LEVEL OF PERFORMANCE AND FUNCTION IN CHEMICAL METERING**

**MD-3 Features Include:**

- The best turnaround in the industry at 2000:1.
- Flow rate: .03–57 GPH (.11–216 LPH). Maximum working pressure: 145 psig (10 bar).
- Smooth chemical dosing, no pulsation dampener needed.
- A single model number will handle all your needs.
- Equipped with Blue-White's exclusive DiaFlex<sup>®</sup> diaphragms.
- Multiple U.S. and international Patents Pending.

# CHEM-PRO<sup>®</sup> M

**METERING  
INJECTOR PUMP**



**PRECISE CHEMICAL METERING  
EVEN AT HIGH PRESSURES**

**CHEM-PRO<sup>®</sup> M Benefits:**

- Chem-Pro<sup>®</sup> M handles system pressures to 175 PSI (12 bar).
- Excellent accuracy and outputs to 40 GPH (153 LPH).
- Operator-friendly user interface. LCD shows Output Volume, Motor % Speed, Input Signals, Service & Alarm Status.
- High resolution motor adjustment 0.5–100%. Output capabilities with 0.1% increments.



**PRECISION CHEMICAL METERING FOR OVER 60 YEARS**

**Blue-White**

[www.proseries-m.com](http://www.proseries-m.com) • [www.blue-white.com](http://www.blue-white.com)

5300 Business Dr., Huntington Beach, CA 92649 USA • 714-893-8529 • [sales@blue-white.com](mailto:sales@blue-white.com)

FREE INFO – SEE ADVERTISER INDEX





## WE TAILOR OUR SCREENING EQUIPMENT TO FIT YOUR NEEDS.

**All wastewater treatment plants are not alike.** That's why plant designers prefer our *Raptor*<sup>®</sup> line of screening products, the innovative all-in-one units that screen, wash, convey and dewater screenings efficiently, capturing more fine solids and long fibers than other available screens. *Raptor*<sup>®</sup> products are adaptable to a wide range of configurations, giving you more choices for better performance in your unique application. They are preferred among plant operators for their simple operation, ease of use, and minimal maintenance. When performance counts, count on the industry leader for more than 85 years—Lakeside Equipment Corporation.

Speak to one of our experts at 630.837.5640, email us at [sales@lakeside-equipment.com](mailto:sales@lakeside-equipment.com), or visit [www.lakeside-equipment.com](http://www.lakeside-equipment.com) for more product information.







Cleaner Water for a Brighter Future<sup>®</sup>













### *Raptor*<sup>®</sup> Screening Products

- Fine Screen
- Micro Strainer
- Rotating Drum Screen
- Wash Press
- Septage Acceptance Plant
- Septage Complete Plant

AdEdge Water Technologies, LLC	25	<input type="checkbox"/>	
	Aerzen USA	45	<input type="checkbox"/>
Airmaster Aerator LLC	4	<input type="checkbox"/>	
All-Star Products	21	<input type="checkbox"/>	
	AllMax Software, Inc.	31	<input type="checkbox"/>
American Pleasure Products, Inc.	77	<input type="checkbox"/>	
American Water Works Association	65	<input type="checkbox"/>	
AmTech Tank Lining & Repair	91	<input type="checkbox"/>	
Analytical Technology, Inc.	118	<input type="checkbox"/>	
	Aqua-Aerobic Systems, Inc.	11	<input type="checkbox"/>
	BDP Industries	73	<input type="checkbox"/>
BinMaster Level Controls	117	<input type="checkbox"/>	
	Blue-White Industries	2	<input type="checkbox"/>

Boerger, LLC	55	<input type="checkbox"/>	
Bright Technologies, Division of Sebright Products, Inc.	83	<input type="checkbox"/>	
Byo-Gon, Inc.	117	<input type="checkbox"/>	
Cam Spray	87	<input type="checkbox"/>	
CEM Corporation	67	<input type="checkbox"/>	
Central Life Sciences	17	<input type="checkbox"/>	
	Centrisys Corporation	81	<input type="checkbox"/>
	ClearSpan Fabric Structures	77	<input type="checkbox"/>
	CNP - Technology Water and Biosolids Corp.	85	<input type="checkbox"/>
	Deep Trekker Inc.	93	<input type="checkbox"/>
Electrolytic Technologies LLC	116	<input type="checkbox"/>	
	Enviro-Care Company	59	<input type="checkbox"/>
Eurus Blower, Inc.	95	<input type="checkbox"/>	
Fatboy Outdoors	113	<input type="checkbox"/>	
Force Flow	89	<input type="checkbox"/>	

Ford Hall Company, Inc.	79	<input type="checkbox"/>	
Fournier Industries, Inc.	91	<input type="checkbox"/>	
	Gardner Denver Inc.	61	<input type="checkbox"/>
Garland Manufacturing Company	89	<input type="checkbox"/>	
	Hach	5	<input type="checkbox"/>
Hayward Flow Control	15	<input type="checkbox"/>	
HEMCO Corporation	117	<input type="checkbox"/>	
	Huber Technology, Inc.	9	<input type="checkbox"/>
Hydro International	63	<input type="checkbox"/>	
	JDV Equipment Corporation	83	<input type="checkbox"/>
	Keller America Inc.	7	<input type="checkbox"/>
Kifco, Inc.	116	<input type="checkbox"/>	
	Komline-Sanderson	69	<input type="checkbox"/>
	Kuhn North America, Inc.	8	<input type="checkbox"/>
	Lakeside Equipment Corporation	3	<input type="checkbox"/>
	Myron L Company	57	<input type="checkbox"/>
	Nasco Whirl-Pak	117	<input type="checkbox"/>
North Carolina Rural Water Association	116	<input type="checkbox"/>	
Park Process	116	<input type="checkbox"/>	
	Penn Valley Pump Co., Inc.	41	<input type="checkbox"/>
ProComSol, Ltd	85	<input type="checkbox"/>	

Pulsed Hydraulics, Inc.	116	<input type="checkbox"/>	
Red Meters	116	<input type="checkbox"/>	
Red Valve Co. / Tideflex Technologies	35	<input type="checkbox"/>	
Rhino Linings Corporation	19	<input type="checkbox"/>	
Robuschi USA	119	<input type="checkbox"/>	
Ronk Electrical	116	<input type="checkbox"/>	
	Roto-Mix, LLC	93	<input type="checkbox"/>
Ruthman Companies	37	<input type="checkbox"/>	
	SAF-T-FLO Chemical Injection	47	<input type="checkbox"/>
	SALCOR, Inc.	95	<input type="checkbox"/>
	ScreenCo Systems LLC	116	<input type="checkbox"/>
<b>SEEPEX.</b> ALL THINGS FLOW	SEEPEX Inc.	71	<input type="checkbox"/>
Shand & Jurs	29	<input type="checkbox"/>	
	Simple Solutions Distributing	116	<input type="checkbox"/>
Singer Valve Inc.	79	<input type="checkbox"/>	
Sunbelt Rentals	27	<input type="checkbox"/>	
Superior Tank Co., Inc.	75	<input type="checkbox"/>	
USALCO, LLC	81	<input type="checkbox"/>	
	Vaughan Company, Inc.	120	<input type="checkbox"/>
Walker Process Equipment, A Div. of McNish Corp.	87	<input type="checkbox"/>	
	Watson-Marlow Fluid Technology Group	53	<input type="checkbox"/>
<b>CLASSIFIEDS</b>	115	<input type="checkbox"/>	



**NEW!**

# INFUSION AERATION.

Technology Raises D/O Levels and Saves Energy.

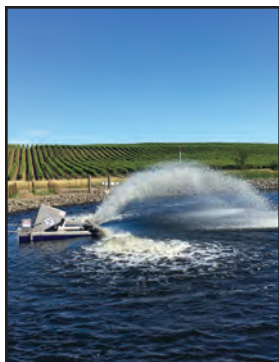

Our new infusion aeration technology aerators improve treatment efficiency and provide maximum mixing, while dramatically raising the dissolved oxygen levels. Using low h.p. motors enables huge energy savings. Call us today for complete details.



888-813-3680 • www.airmasteraerator.com

**FREE Information from Advertisers** (check the Free Info boxes above)

PRINT NAME: \_\_\_\_\_ TITLE: \_\_\_\_\_

FACILITY NAME: \_\_\_\_\_

MAILING ADDRESS: \_\_\_\_\_

CITY: \_\_\_\_\_ STATE: \_\_\_\_\_ ZIP: \_\_\_\_\_

PHONE: \_\_\_\_\_ CELL PHONE: \_\_\_\_\_

FAX: \_\_\_\_\_ EMAIL: \_\_\_\_\_

Scan and email to: [nicole.labeau@colepublishing.com](mailto:nicole.labeau@colepublishing.com) / Fax to: 715-546-3786  
 Mail to: COLE Publishing Inc., P.O. Box 220, Three Lakes WI 54562



# WELCOME TO THE POWER OF CLARITY



Be Right™

Only Hach provides a solution of connected instruments and software to end uncertainty in your water, 24/7. Streamline your operations and costs. Ensure compliance. When data becomes actionable insight — that's **The Power of Clarity**.

[hach.com/clarity](https://hach.com/clarity)

FREE INFO - SEE ADVERTISER INDEX





### on the cover

Residents of New Jersey's Monmouth and Ocean counties enjoy high-quality water supplied by production supervisor Matt Walsh and colleagues at the 15-year Directors-Award-winning Jumping Brook Water Treatment Plant in Neptune Township and the 36 mgd Swimming River plant in Colts Neck. (Photography by James Robinson)

## top performers:

### WASTEWATER PLANT Page 22

#### All the Right Pieces

A dedicated and well-equipped staff keeps the Kimmswick Wastewater Treatment Facility running smoothly and looking sharp.

By Ted J. Rulseh

### WASTEWATER OPERATOR Page 32

#### Magnificent Mentor

Ken Burgener shares his love of science and the clean-water profession with students who represent the next generation of operators and lab technicians.

By Jim Force

### WASTEWATER PLANT Page 12

#### It's the Culture

Safe practices are built right into work procedures and team members' attitudes at the Glenbard Wastewater Authority.

By David Steinkraus

### WATER PLANT Page 38

#### The Old and the New

The Jumping Brook Water Treatment Plant used tube settlers to drive down turbidity and earn a 15-year Directors Award from the Partnership for Safe Water.

By Steve Frank

### LET'S BE CLEAR Page 8

#### Looking Sharp

If you want the treatment plant team to have "firefighter status," then it helps to make the plant look just as good as the firehouse.

By Ted J. Rulseh, Editor

### @TPOMAG.COM Page 10

Visit daily for exclusive news, features and blogs.

### HOW WE DO IT Page 20

#### A Safer Way

The largest clean-water plant in Anchorage makes the switch from chlorine gas disinfection to sodium hypochlorite generated on site.

By Ted J. Rulseh

### TECH TALK Page 30

#### Catch the Vibe!

Falling costs and greater simplicity in vibration monitoring systems enable plant operators to do predictive maintenance on high-value and basic equipment.

By Chris Hansford

### PLANTSCAPES Page 36

#### Growing Diversity

A constructed grassland on water plant site that was once a farm is now home to abundant native plants and a rich variety of wildlife.

By Jeff Smith

### IN MY WORDS Page 42

#### Just One Water

The newly formed Water Environment & Research Federation sets research priorities that

focus on a more integrated approach to water management.

By Ted J. Rulseh

### TECHNOLOGY DEEP DIVE Page 44

#### Beyond Settling

Hydro MicroScreen technology combines fine screening and primary treatment, helping plants save space and enhance efficiency.

By Ted J. Rulseh

### SUSTAINABLE OPERATIONS Page 46

#### Target Net Zero

The wastewater treatment plant in Wyoming's Jackson Hole takes progressive steps to fit in with its environmentally sensitive surroundings.

By Doug Day

### HEARTS AND MINDS Page 48

#### Going With the Flow

Hands-on activities teach Maine middle school students about the water cycle, runoff prevention and watershed preservation.

By Craig Mandli

### ANNUAL COMPANY DIRECTORY Page 50

### PRODUCT NEWS Page 110

Product Spotlight – Wastewater: Scale allows operators to accurately gauge polymer usage; Product Spotlight – Water: B-frame circuit breaker offers smaller footprint, installation flexibility.

By Craig Mandli

### INDUSTRY NEWS Page 112

### WORTH NOTING Page 114

People/Awards; Events

---

coming next month: June 2017

### FOCUS: ACE Show Issue/ Odor Control and Disinfection

- » Let's Be Clear: Shielding low-income users from major rate increases
- » Top Performers:
  - Wastewater Plant: Utility of the future in Fairfax, Virginia
  - Water Plant: Adapting to membranes in Cottage Grove, Oregon
  - Wastewater Operators: Heroic actions in Columbia, South Carolina
  - Water Operator: Eric Gonzales, SUEZ North America
- » How We Do It: Water distribution pumping strategies
- » Sustainable Operations: Food waste to energy in New York City
- » In My Words: A novel approach to training the next generation
- » Tech Talk: The finer points of jar testing
- » PlantScapes: Tree farm in North Tonawanda, New York
- » Technology Deep Dive: Ionization technology for odor control





# SUCCESS, in the end, means KELLER from the beginning

Keller America manufactures level and pressure instrumentation built to provide years of low maintenance, worry free operation for water and wastewater professionals who need to monitor and control processes where reliable measurements are critical. For the very best in level and pressure instrumentation, think Keller... from the beginning.

## **Preciseline high-accuracy digital pressure transmitter**

- Built to order in the United States
- Custom cable lengths and ranges up to 15,000 PSI
- Dual outputs - One analog and one digital RS485
- Guaranteed lightning protection at no additional cost
- Standard 3-day lead time





## WIDE DISCHARGE, IMPROVED MATERIAL BREAKUP



Adjustable Hammer Shroud

### SLC 100 SERIES PROTWIN® SLINGER®



- All-new discharge provides faster unloading, more consistent spreading
  - Twin-auger design eliminates material bridging
  - Fully enclosed oil bath for low maintenance and long life
  - Optional scales for precise monitoring and nutrient tracking
- 3200, 4100 and 5000 gallon capacities • truck & trailer models

Kuhn North America • Brodhead, WI • (608) 897-2131 [KuhnNorthAmerica.com](http://KuhnNorthAmerica.com)   

FREE INFO – SEE ADVERTISER INDEX



DEDICATED TO WASTEWATER & WATER TREATMENT PROFESSIONALS

Published monthly by COLE Publishing, Inc.

1720 Maple Lake Dam Rd., PO Box 220, Three Lakes, WI 54562

Call toll free 800-257-7222 / Outside of U.S. or Canada call 715-546-3346  
Mon.-Fri., 7:30 a.m.-5 p.m. CST

Website: [www.tpomag.com](http://www.tpomag.com) / Email: [info@tpomag.com](mailto:info@tpomag.com) / Fax: 715-546-3786

**SUBSCRIPTION INFORMATION:** A one year (12 issues) subscription to TPO™ in the United States and Canada is FREE to qualified subscribers. A qualified subscriber is any individual or company in the United States or Canada that partakes in the consulting, design, installation, manufacture, management or operation of wastewater and water treatment facilities. To subscribe, return the subscription card attached to each issue, visit [tpomag.com](http://tpomag.com) or call 800-257-7222.

Non-qualified subscriptions are available at a cost of \$60 per year in the United States and Canada/Mexico and \$150 per year to all other foreign countries. To subscribe, visit [tpomag.com](http://tpomag.com) or send company name, mailing address, phone number and check or money order (U.S. funds payable to COLE Publishing Inc.) to the address above. MasterCard, VISA and Discover are also accepted. Include credit card information with your order.

**ADDRESS CHANGES:** Submit to TPO, P.O. Box 220, Three Lakes, WI, 54562; call 800-257-7222 (715-546-3346); fax to 715-546-3786; or email [nicole.labeau@colepublishing.com](mailto:nicole.labeau@colepublishing.com). Include both old and new addresses.

Our subscriber list is occasionally made available to carefully selected companies whose products or services may be of interest to you. Your privacy is important to us. If you prefer not to be a part of these lists, please contact Nicole at [nicole.labeau@colepublishing.com](mailto:nicole.labeau@colepublishing.com).

**ADVERTISING RATES:** Call 800-994-7990 and ask for Phil or Kim or email [phil.hahn@colepublishing.com](mailto:phil.hahn@colepublishing.com) or [kim.bruss@colepublishing.com](mailto:kim.bruss@colepublishing.com). Publisher reserves the right to reject advertising which in its opinion is misleading, unfair or incompatible with the character of the publication.

**EDITORIAL CORRESPONDENCE:** Address to Editor, TPO, P.O. Box 220, Three Lakes, WI, 54562 or email [editor@tpomag.com](mailto:editor@tpomag.com).

**REPRINTS AND BACK ISSUES:** Visit [www.tpomag.com](http://www.tpomag.com) for options and pricing. To order reprints, call Jeff Lane at 800-257-7222 (715-546-3346) or email [jeff.lane@colepublishing.com](mailto:jeff.lane@colepublishing.com). To order back issues, call Nicole at 800-257-7222 (715-546-3346) or email [nicole.labeau@colepublishing.com](mailto:nicole.labeau@colepublishing.com).

**CIRCULATION:** 68,317 copies per month.

© 2017 COLE PUBLISHING INC.

No part may be reproduced without permission of publisher.



let's be clear

## Looking Sharp

IF YOU WANT THE TREATMENT PLANT TEAM TO HAVE 'FIREFIGHTER STATUS,' THEN IT HELPS TO MAKE THE PLANT LOOK JUST AS GOOD AS THE FIREHOUSE

By Ted J. Rulseh, Editor

If you had to describe a hierarchy for public officials' status among community residents, firefighters would be near the top; water and wastewater treatment operators would be near the bottom.



That's not to say such rankings are justified, that's just how it happens to be in many if not most cases. In the past, this column has promoted The Fire Chief Project, with two aims:

- Raise operators to the status of the fire chief
- Make kids grow up wanting to be operators

### VISUAL APPEAL

There are a variety of steps to take toward making that happen. One of them is to make the treatment plant look as good (or almost as good) as the firehouse. Think about it for a moment. In a typical community, the

firehouse is in the middle of town, an architecturally attractive building with a manicured landscape, flower beds, maybe a display of a restored antique fire engine behind glass.

Meanwhile, the treatment plant sits at the end of a road outside of town, or in an industrial area next to the river, likely surrounded by a chain-link fence. A sign with the facility name routed into plain boards is all that greets visitors.

Of course, this is a stereotype, and not really a fair one. Some treatment plants have strong visual appeal, reflecting the community's vision and the operators' pride. And not every firehouse is a showpiece — some are simply nondescript buildings with big garage doors.

A simple fact remains, though: Many water and wastewater plants could use a lot of sprucing up. The regular PlantScapes article in TPO encourages that. Over the years we've featured plants that added murals, gardens, tree plantings, walking paths and various other amenities.

### NATURAL SETTINGS

When it comes to beautifying, treatment plants have some natural advantages and some built-in challenges. One key challenge is dealing, in many cases, with a site that is



outside the normal traffic flow and out of the public eye, and wouldn't attract much attention no matter how attractively landscaped.

One natural advantage is that plants often have large properties that lend themselves to ambitious projects like arbore-tums, prairie plantings and boardwalks alongside neighboring rivers or marshes for birdwatching and wildlife viewing.

This month's PlantScapes article describes how the operators of the Philips Street Water Treatment Plant near Kokomo, Indiana, created a field of native grasses, wildflowers and trees to attract nesting birds and other wild creatures.

### WHY IT MATTERS

Of course, even the simplest aesthetic improvements take time and money, both in short supply these days. Fire departments, it could be argued, have the advantage of "free" labor — the firefighters can work on the landscape during hours at the station not dedicated to activities like training and equipment maintenance. Water and wastewater plants don't have that luxury.

An alternative is to engage with a local garden club, high school FFA chapter or other community group to revitalize the grounds. Outside of that, a strong argument can be made for the community to invest in site plant improvements.

It's well known that water and wastewater plants need periodic upgrades, along with continued investment for maintenance. There often comes a time when the community must ask residents for a rate increase to cover those expenses.

An attractive facility — even if rarely seen except when public groups or school classes take tours — adds to the perception that the service being provided is indispensable and deserves financial support.

Getting approval is much easier if the public sees the water or wastewater plant as an essential facility that supports high quality of life. An attractive facility — even if rarely seen except when public groups or school classes take tours — adds to the perception that the service being provided is indispensable and deserves financial support.

### TELL YOUR STORY

What have you done, in ways big or small, to improve the appearance of your facility? What challenges did you face? Where did you find the funds? Who did the actual work? Tell about your experiences in an email to editor@tpomag.com. We'll report them in a future issue. [tpo](mailto:editor@tpomag.com)



*inspiring,  
stimulating,  
motivating*

Savored by wastewater and water treatment professionals everywhere.

Get your fill for free. Subscribe at [tpomag.com](http://tpomag.com)

## PROTECT SYSTEMS DOWNSTREAM



### RPPS Star Centerfeed Fine Screen

**Superior** screenings removal  
with openings as small as 1 mm

**Patented** design increases  
throughput by 40%

**Original** designer of  
the Rotamat

**Award** winning  
service & support

**Simple**  
to operate

See how it works at:  
[huberforum.net/star](http://huberforum.net/star)  
[solutions@hhusa.net](mailto:solutions@hhusa.net)  
704-990-2053

**HUBER**  
**TECHNOLOGY**  
WASTE WATER Solutions



Visit the site daily for new, exclusive content. Read our blogs, find resources and get the most out of *TPO* magazine.



## PUBLIC OUTREACH

### The Importance of Tours

Treatment plants like the Jones Island Water Reclamation Facility in Milwaukee, Wisconsin, are starting to remedy the public's general unfamiliarity with the wastewater industry through quality public relations programs and enhanced tours of facilities. Take a look at the 91-year-old treatment plant through the eyes of a native Milwaukeean who previously had little clue about what happened beyond the drain.

[Tpmag.com/featured](#)

## RETAIN EMPLOYEES

### Use a Clear Job Ladder

Restructuring your treatment plant's job ladder could be the key to giving employees the incentive they need to stay in the wastewater industry, according to guest blogger Jeff Kalmes. In the last 12 years, Kalmes climbed the rungs from operator to lab tech before ultimately becoming the plant superintendent at the Town of Billerica Wastewater Treatment Plant in Massachusetts.

[Tpmag.com/featured](#)



## OVERHEARD ONLINE

“With its innate ability to generate electricity, the little powerhouse might one day pave the way for making wastewater drinkable.”

*The Little Bacterium That Could*  
[Tpmag.com/featured](#)

## ANALYZING WASTEWATER

### Assessing Public Health

Most people see wastewater treatment plants as vital components of modern infrastructure, but professor Rolf Halden of Arizona State University's Biodesign Institute sees them as windows into our behavior and well-being. He's leading a research team that analyzes sewage samples from wastewater treatment plants to identify behavioral trends and assess potential public health threats.

[Tpmag.com/featured](#)



## Emails & Alerts

Visit [TPOmag.com](#) and sign up for newsletters and alerts. You'll get exclusive content delivered right to your inbox, and you'll stay in the loop on topics important to you.



## Join the Discussion

[Facebook.com/TPOmag](#)

[Twitter.com/TPOmag](#)



# THE WAIT IS OVER

THE FUTURE OF WASTEWATER TREATMENT IS HERE.



Following more than a decade of successful application worldwide, the **AquaNereda® Aerobic Granular Sludge System** is now available in the United States. This advanced biological treatment technology utilizes unique features of aerobic granular biomass including superior settling properties when compared to conventional activated sludge. Additional advantages translate into a flexible, compact and energy efficient process.

- Up to 75% Less Footprint
- Energy Savings Up to 50%
- Virtually No Chemicals Required for Nutrient Removal
- SVI Values of 30-50 mL/g and MLSS of 8,000 mg/l
- No Secondary Clarifiers, Selector Zones or Return Sludge Pumping
- Robust Process without a Carrier

Aqua-Aerobic Systems, Inc. is the exclusive U.S. provider of Nereda® technology developed by Royal HaskoningDHV.

**ACE**<sup>17</sup>  
WORLDWIDE CONFERENCE & EXHIBITION  
**Booth 1401**



**AQUA-AEROBIC SYSTEMS, INC.**  
A Metawater Company

[www.AquaNereda.com](http://www.AquaNereda.com) | 815-654-2501

FREE INFO – SEE ADVERTISER INDEX



# It's the *Culture*

SAFE PRACTICES ARE BUILT RIGHT INTO WORK PROCEDURES AND TEAM MEMBERS' ATTITUDES AT THE GLENBARD WASTEWATER AUTHORITY

STORY: **David Steinkraus**  
PHOTOGRAPHY: **Rob Hart**

LOOK AROUND ANY WORKPLACE AND THE SAFETY materials are hard to miss. There are safety posters, videos, course announcements, booklets, stickers, tip sheets and more.

But safety takes more than that. True workplace safety requires action. At the Glenbard Wastewater Authority in Glen Ellyn, Illinois, employees have worked for more than three years without a major lost-time injury.

That earned the facility the George Burke Jr. Safety Award from the Central States Water Environment Association and a Water Environment Federation Safety Award for 2016, but the accomplishment didn't stop there. As of November 2016, the authority had reached 1,300 injury-free days, and even that was not a record. "Our previous record is 1,680 days," says Gayle Lendabarker, executive secretary. That ended in 2009 with a shoulder injury.

## IT TAKES A CULTURE

The secret is straightforward: "You have to create a safety culture," says Erik Lanphier, the authority's executive director. "You get people to commit, you educate them, and then you continuously support their efforts. Safety has always been one of our top priorities."

Since he started working at Glenbard in 1999, there has been an active safety review committee, an initiative of a former manager who came from an industrial background and wanted to apply the safety lessons he learned.



"I really bought into safety," Lanphier says. "I've been in this industry since 1989. I know the hazards of it. I've seen people get hurt in it. I've been hurt in it."

The Safety Committee includes a representative from each department. Each meeting has a formal agenda and includes discussions about safety and what each department is doing. Employees can submit safety suggestions, and near misses and unsafe conditions are reported.

"We also reward the employees," Lanphier says. "Every two months we give people a \$20 gift card for not having any lost-time injuries. And we do that with local businesses so our money is recirculated through the community."





Jon Braga (left) and Austin Cecelia, mechanics, check the combined heat and power engine-generator (Generac) at the Glenbard Wastewater Authority.

Anyone can submit a safety suggestion, and the safety committee evaluates each one. Employees receive points for making suggestions, and the number of points governs the size of another gift card they can earn.

Any suggestion that shows an immediate risk to health and life is turned into a report of an unsafe condition. That report first goes to the employee's supervisor, who must sign it, and then to the most appropriate person to fix the problem, who also must sign. Remedial work must be done within 48 hours.

The authority also holds tailgate events, in which a group assembles to

## Glenbard Wastewater Authority, Glen Ellyn, Illinois

BUILT: | 1982

POPULATION SERVED: | 104,000

SERVICE AREA: | 22 square miles

FLOWS: | 16.02 mgd design; 12 mgd average

TREATMENT LEVEL: | Tertiary

TREATMENT PROCESS: | Advanced high-purity oxygen activated sludge

RECEIVING WATER: | East Branch, DuPage River

BIOSOLIDS: | Land-applied, Class B

ANNUAL BUDGET: | \$4.1 million

WEBSITE: | [www.gbww.org](http://www.gbww.org)

GPS COORDINATES: | Latitude: 41°50'49.05"N; longitude: 88°2'43.12"W



address one issue. For example, as the time approaches for maintenance on the UV disinfection system, a supervisor may review the process of pulling out the lamps and dipping them in a solution of 85 percent phosphoric acid to remove fouling. New employees go through a checklist of training videos covering topics from use of personal protective equipment to electrical and vehicle safety.





Erik Lanphier, left, executive director, and David Goodalis, operations superintendent.

## HEADING OFF DANGER

Glenbard takes near misses seriously, and fortunately they are infrequent. At some facilities, a near miss may be a reason to reprimand an employee. Glenbard sees it differently. Near misses are discussed openly at staff meetings. If employees know that near misses will not mean disciplinary action, they feel free to report them so that dangerous conditions or behaviors can be corrected.

“You have to create a safety culture. You get people to commit, you educate them, and then you continuously support their efforts.”

**ERIK LANPHIER**

About a decade ago, the time came for a regular UV lamp inspection. “I thought we had safety glasses on the door that were UV protective,” Lanphier says. “So I put on the safety glasses, and for eight hours I was looking at UV bulbs. By about 2 o’clock, I felt like there were pins being pushed into my eyeballs. I couldn’t see, so one of the guys took me to an optometrist. He told me I had essentially sunburned my eyes. Fortunately that’s a short-term problem, but it does make you realize that you can’t take safety for granted. Safety is not a given. It’s something you have to work for.”

That sort of incident qualifies as an unsafe condition, requiring remediation. All the safety glasses now have UV-protective coatings.

*(continued)*

## TWO GOVERNMENTS, ONE SERVICE

The Illinois villages of Glen Ellyn and Lombard sit next to each other about 19 miles straight west of downtown Chicago.

They are lost in a suburban landscape where one community blends into the next, yet they are not at all the same as their neighbors, because years ago city leaders created an agreement that led to a single wastewater treatment plant serving both communities. The authority is wholly owned and controlled by the governments that established it.

“I’ve found only one other wastewater authority in the state, and it is run much differently than we are,” says Erik Lanphier, executive director of the Glenbard Wastewater Authority.

The initial agreement to share services was signed in 1968, and the impetus for it was the development of the southern part of Lombard.

That section of the village is almost opposite the site of the present wastewater plant, and without cooperation, Lombard had no way to move wastewater to its own treatment plant on its north side. In 1978, the two villages officially created the Glenbard Wastewater Authority, and in 1984 they set up an executive oversight committee

on which each community is represented by the village president, one trustee, the village manager and the Public Works director.

The villages review their agreement periodically. They review the overhead fees annually because the authority pays the village of Glen Ellyn, the lead agency, for personnel services and other expenses. “These two communities are diametrically different,” says Lanphier. “Glen Ellyn is home rule and Lombard is not. Lombard is unionized and Glen Ellyn is not.”

The authority structure enables the communities to work together for one purpose despite their differences. Once a month, leaders of the communities meet and solve common problems. That creates an attitude that can be expanded to other issues both face. It helps the authority staff, too, because they hear the ideas and approaches of both governments, Lanphier says.

All that positive energy has not gone unnoticed. The authority has received calls from other local governments that want to copy its successes, such as the safety program. Says Lanphier, “That’s the intent: to take that positive energy and hope other people will bite into it.”



**System2™**  
Sealing Technology  
creates a backup  
secondary seal  
between upstream  
seat and ball

# A Seal Above the Rest

The new **Hayward TBH Series True Union Ball Valve** with **System2™ Sealing Technology\*** delivers extended lifetime performance vs. conventional thermoplastic ball valves.

The revolutionary System2™ Sealing Technology incorporates a “floating seat” design, thus utilizing the valve’s upstream seat as a backup to the downstream seat while actually enhancing the sealing of the downstream seat.



## KEY FEATURES

- **Technology:** System2™ Sealing Technology provides longer cycle life
- **Performance:** 250 psi/PN16, non-shock at 70°F/23°C full pressure rating
- **Dependability:** Consistent operating torque with adjustment free design
- **Safety:** Lockout/Tagout mechanism that secures directly to valve body for enhanced security
- **Comfort:** Ergonomic handle for improved grip and comfort
- **Flexibility:** ISO mounting flange for easiest thermoplastic valve to actuate

Visit us online at [haywardflowcontrol.com](http://haywardflowcontrol.com) or call **1.888.429.4635** for more information or to arrange a product demonstration on the new TBH Series Ball Valve from Hayward.

\* Patent Pending





## TEAM MAKES IT WORK

The credit for the authority's safety record belongs to the entire plant staff, which includes:

- Erik Lanphier, executive director
- Gayle Lendabarker, executive secretary
- David Goodalis, operations superintendent
- Operators Chris Dillmann, Andy Pakosta, Joe Kovac and Jason Neighbors
- Richard Freeman, electrical superintendent, and Joseph Solita, plant electrician
- Philip Dziewior, instrumentation technician
- Jay Dahlberg, maintenance superintendent, and mechanics Jon Braga, Henry Altott and Austin Cecelia
- Laurie Frieders, environmental resource coordinator
- Matt Streicher, assistant director and engineer
- David Peters, lab technician

The same team ensures that the treatment process performs efficiently and that the plant consistently meets its permit. The team does considerable work in-house. Solita, for example, has an industrial background and is comfortable doing long conduit runs. Freeman is in charge of the SCADA system, helped develop it, and can write code for it. "Having such expertise on site has saved the authority about \$150,000 during the last two years," says Lanphier.

## UNOX HELPS THE PROCESS

Wastewater comes to the plant from the villages of Glen Ellyn and Lombard, an unincorporated area of DuPage County, and Illinois American Water, a private water services company. Water moves to the plant through a 60-inch line. After the water passes through bar screens (Headworks International), a pair of pumps (Flygt - a Xylem brand) lift it to provide gravity flow through the rest of the primary process. Influent next reaches the grit building with a vortex separation system (Smith & Loveless) and a grit classifier (Huber Technology).

After passing through the two primary clarifiers, wastewater flows into a high-purity oxygen activated sludge process that helps ensure a high dissolved oxygen level in the effluent discharged to the DuPage River, locally

classified as an impaired waterway. The 10-train, four-stage UNOX deck, equipped with Lightning mixers, is fed with oxygen from a Union Carbide 32-ton-per-day cryogenic oxygen plant on site. The covered basins and the process itself effectively control odors, and some homes are as close as 30 feet from portions of the plant.

After passing through carbonaceous BOD reduction and a set of intermediate clarifiers, Archimedes screw pumps (Lakeside Equipment Corporation) send water back to the UNOX deck for second-stage aeration. The eight trains in the second treatment stage reduce ammonia. After flowing through the four final clarifiers, water passes through 10 sand filters before UV disinfection (Ironbrook UV Corp).

Biosolids are gravity thickened and then fed through belt presses (Alfa Laval Ashbrook Simon-Hartley). The authority can store 2,000 cubic yards on site. The material is land-applied.

## INFORMING THE PUBLIC

Glenbard maintains good relations with plant neighbors and customers. "Instead of taking a problem to a village board, neighbors are not hesitant to call here first when they have a question," Lendabarker says. "That shows the rapport we have with the community."

When trucks haul biosolids, the authority sends letters to surrounding homes, mainly those on the main access road, and posts the information on its website. The team encourages residents to sign up for the plant's email

*(continued)*

Glenbard Wastewater Authority PERMIT AND PERFORMANCE (2016 Annual Average)			
	INFLUENT	EFFLUENT	PERMIT
<b>CBOD</b>	162.5 mg/L	1.9 mg/L	10 mg/L monthly avg. 20 mg/L daily max.
<b>TSS</b>	192 mg/L	3.5 mg/L	12 mg/L monthly avg. 24 mg/L daily max.
<b>Fecal Coliform</b>	—	1	400 per 100 mL



After flowing through the four final clarifiers like this one, wastewater passes through 10 sand filters.



# STRIKE

# IN THE WATER

STRIKES MIDGE FLIES DOWN



## STOP THE SWARM IN WASTEWATER MANAGEMENT FACILITIES

Strike® Professional Midge Control is the easy and environmentally compatible solution to midge fly infestations. Available in multiple formulations, Strike® products control midge and filter flies by eliminating the next generation of flies with an EPA-approved insect growth regulator. Strike® products do not contain any dangerous toxins, posing no threat to non-target organisms. With a short half-life, Strike® products are typically undetectable in water tests, making it easy to count on them for control.

For more information visit  
[StrikeProducts.com](http://StrikeProducts.com)



**STRIKE**  
Professional Midge Control





From left, David Goodalis, Erik Lanphier and Jon Braga discuss the day's priorities.

“ Instead of taking a problem to a village board, neighbors are not hesitant to call here first when they have a question. That shows the rapport we have with the community.”

**GAYLE LENDABARKER**

service. “We do a lot of tours here with schools, from elementary schools through college,” Lanphier says.

The authority works with the Glen Ellyn Environmental Commission on projects that include a drive to encourage grocery stores to stop using plastic bags, suggesting solar-powered trash compactors for the central business district, and establishing a rain barrel purchase program.

## FUTURE PROJECTS

The authority has just let bids for a \$17 million project that will install a new lower wet well with pre-rotation basins to increase the flow velocity in incoming lines. The project will also install new variable-speed Flygt pumps. Another phase will be replacement of the tertiary sand filters with disc filters (Kruger).

As part of a working group for the DuPage River, the authority will contribute more than \$2 million to improving the watershed. That includes projects such as removing dams and in general working to recreate the stream flows that existed before urbanization. Both villages are on board with this initiative.

“When you really think about who is responsible for the streams, no one is responsible for the streams unless you get one of these groups involved,” Lanphier says. “We believe we should work toward fixing what is broken rather than spend more tax dollars on point source discharge solutions that we are not sure will work.” **tpp**

## featured products from:

**Alfa Laval Ashbrook  
Simon-Hartley**  
866/253-2528  
[www.alfalaval.us](http://www.alfalaval.us)

**Flygt - a Xylem Brand**  
855/995-4261  
[www.xylem.com/pumping](http://www.xylem.com/pumping)

**Generac Industrial Power**  
888/436-3722  
[www.generac.com](http://www.generac.com)

**Headworks International, Inc.**  
713/647-6667  
[www.headworksintl.com](http://www.headworksintl.com)

**Huber Technology, Inc.**  
704/949-1010  
[www.huberforum.net](http://www.huberforum.net)  
(See ad page 9)

**Ironbrook UV Corp**  
905/478-1022  
[www.ironbrookuv.com](http://www.ironbrookuv.com)

**Kruger USA**  
919/677-8310  
[www.krugerus.com](http://www.krugerus.com)

**Lakeside Equipment Corporation**  
630/837-5640  
[www.lakeside-equipment.com](http://www.lakeside-equipment.com)  
(See ad page 3)

**Smith & Loveless, Inc.**  
800/898-9122  
[www.smithandloveless.com](http://www.smithandloveless.com)



# Protection, Worldwide.

Global provider of high performance coatings, linings and foam



With more than 25 years of product innovation and a global network of distributors and applicators, the world has come to know and trust Rhino Linings® products' quality, strength and durability.

Join our global network or find an authorized Rhino Linings applicator near you.



[rhinolining.com/industrial](http://rhinolining.com/industrial) | 1-800-422-2603



Always use the proper safety gear and protective clothing when using Rhino Linings products. All businesses are independently owned and operated. ©2017 Rhino Linings Corporation. All rights reserved. TPO 7474

FREE INFO - SEE ADVERTISER INDEX



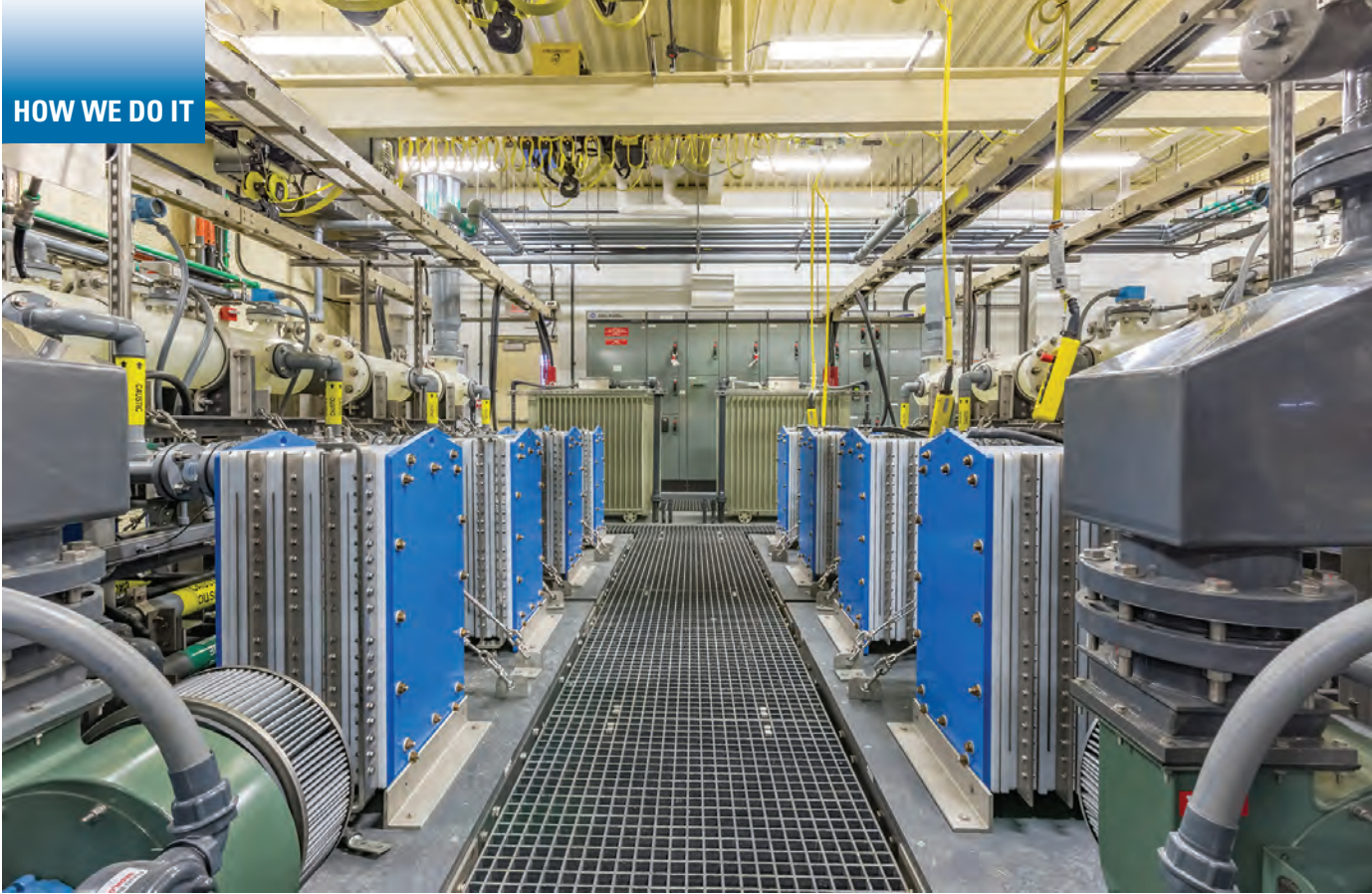

The on-site sodium hypochlorite generation system (Electrolytic Technologies) is designed to be compatible with the utility's current operations and for ease of expansion to meet future demand.

# A Safer Way

THE LARGEST CLEAN-WATER PLANT IN ALASKA MAKES THE SWITCH FROM CHLORINE GAS DISINFECTANT TO SODIUM HYPOCHLORITE GENERATED ON SITE

By Ted J. Rulseh

For years, the Anchorage Water & Wastewater Utility had used chlorine gas as the disinfectant at its water and wastewater treatment plants.

In the late 1990s, the utility changed direction. "Our main concern was risk to the community," says David Persinger, P.E., director of the AWWU treatment division. "In Alaska, everything comes by truck or barge. The chlorine cylinders were barged in.

"Our port is just north of downtown Anchorage. So the 2,000-pound cylinders, usually 12 at a time, had to be transported on a truck through the downtown and some residential areas to get out to our main treatment plant. Then there were heightened security issues that came about after 9/11. There are also process safety management and EPA risk management issues with chlorine gas."

In view of all that, the utility looked at alternative disinfectants. For the Asplund Wastewater Treatment Facility, the largest wastewater plant in Alaska (58 mgd design, 26 mgd average), the utility chose an on-site sodium hypochlorite generation system supplied by Electrolytic Technologies. The disinfection upgrade earned the utility a Best Projects Award and a Safety Award from *Engineering News-Record*, North West Region.

## PART OF A PROGRAM

The Asplund plant upgrade, completed in December 2015, finished the utility's transition away from chlorine gas at all its treatment facilities. First to change over, starting in 2000, were the two water treatment plants with

design capacities of 35 and 4 mgd. They received on-site systems (Severn Trent ClorTec) generating 0.8 percent sodium hypochlorite.

Next came the utility's two smaller wastewater treatment plants. The 2.5 mgd plant with secondary and tertiary treatment serving the Eagle River community and outlying areas north of Anchorage was converted to UV disinfection. The 0.6 mgd Girdwood treatment plant with secondary and tertiary treatment, serving a ski resort and vacation home community about 30 miles south of Anchorage, switched to a 12.5 percent solution of purchased hypochlorite.

For the Asplund primary treatment plant serving Anchorage proper and discharging to Cook Inlet, the utility evaluated UV, ozone and hypochlorite. "We narrowed it down to on-site-generated hypochlorite, either 0.8 percent or 12.5 percent," Persinger says. "We noted that 0.8 percent requires a much bigger building footprint and is a bit less efficient in energy, water and salt consumption. In addition, with the volumes we would be using, 0.8 percent would require quite a bit of storage and a pretty high feed rate. That narrowed it down to the 12.5 percent solution."

## EFFECTIVE SOLUTION

The utility ultimately installed the Klorigen hypochlorite generation system from Electrolytic Technologies, a system designated by the U.S. Department of Homeland Security as a Qualified Anti-Terrorism Technology. The company custom designed the technology to accommodate the util-



ity's needs, including compliance to local seismic design standards. It can generate 5,000 gpd.

The system was installed in two phases. "We completely rebuilt our disinfection building," says Persinger. "About half of that building had been dedicated to cylinder storage and the gas feed system, and the other half was a workshop area.

"The initial phase was to build out the storage and feed system for the hypochlorite process. We installed the storage tanks, the pumps and all the instrumentation required to feed the disinfection process. Once that was completed, we functioned with purchased hypochlorite while the contractor installed the generation equipment in the other half of the building."

The new system is designed to be compatible with the utility's current operations and for ease of expansion to meet future demand. It is unique in including a gas split mechanism that sends part of the generated chlorine gas directly to the point of application and the rest to the hypochlorite conversion skid.

“Because we didn't want to import caustic ... to supplement our hypochlorite production, we went with the hybrid system. The excess chlorine gas produced is fed directly into the effluent stream for disinfection, and then we vary the flow of hypochlorite to meet our disinfection residual requirement.”

DAVID PERSINGER, P.E.

### HYBRID PROCESS

"It's an ion-selective membrane process that basically splits salt so that you end up with chlorine gas on one side of the membrane and caustic on the other," says Persinger. "In conventional installations, generally more gas is produced than caustic to recombine, so the result is an imbalance. Most of those systems require transport of supplemental caustic so that 100 percent of the chlorine gas can be converted to sodium hypochlorite.

"Because we didn't want to import caustic, due to logistical and safety issues, to supplement our hypochlorite production, we went with the hybrid system. The excess chlorine gas produced is fed directly into the effluent stream for disinfection, and then we vary the flow of hypochlorite to meet our disinfection residual requirement."

The system uses extremely pure salt and softened water. The process uses sodium bisulfite to neutralize the depleted brine solution produced before that solution is recirculated to the front end of the process. Hydrochloric acid is used in the automated cleaning process that periodically removes chemical deposits.

AWWU personnel worked closely with the installation contractor and the on-site engineer in charge of construction management to become familiar with the technology and the safety precautions required during operation.

"We also had quite a bit of training from the vendor," says Persinger. "After completion of the project, we did in-house startup and commissioning training. Anytime we have an issue with the equipment, we involve as many people from our maintenance shop as possible, so they can understand the issue and get to know the system better." **cpo**

### Share Your Ideas

TPO welcomes news about interesting methods or uses of technology at your facility for future articles in the How We Do It column.

Send your ideas to editor@tpomag.com or call 877/953-3301

## All Star Certified IP55 Enclosure

ALL STAR . . . .  
the only company offering a *Certified IP55* enclosed regenerative blower.



Test results performed by F2Labs an independent testing laboratory *certified* the All Star IP55 enclosure meets international standards for electrical enclosures. Now you can provide your customers with a product that will perform in the most demanding applications. From fine powders to washdown (even immersion), the All Star IP55 blower is the most reliable and dependable blower today.

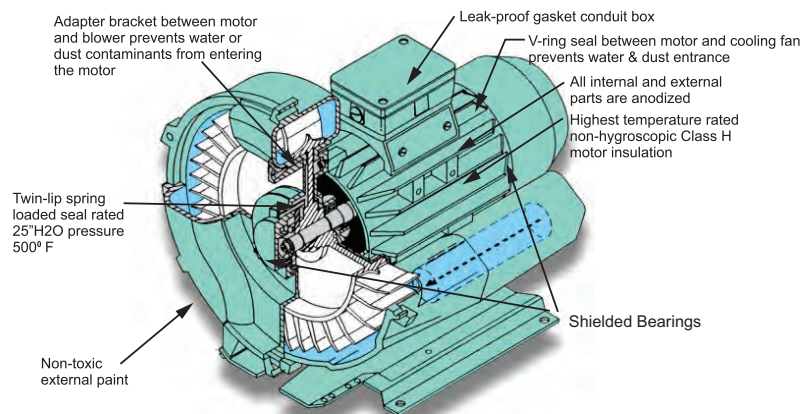

Anodized aluminum parts available

Registered and approved by one or more of these standards agency



<http://www.all-star-usa.com>





# All the *Right Pieces*

A DEDICATED AND WELL-EQUIPPED STAFF KEEPS THE KIMMSWICK WASTEWATER TREATMENT FACILITY RUNNING SMOOTHLY AND LOOKING SHARP

STORY: **Ted J. Rulseh**

PHOTOGRAPHY: **Denny Medley**

YOU COULD EASILY SAY THE KIMMSWICK WASTEWATER Treatment Facility has all the parts in place for award-winning performance.

The eight plant operations and maintenance team members bring experience, high-level certifications and dedication to excellence. And the plant's equipment maintenance program is built on computerized management and an impressive supply of in-stock replacement parts for critical equipment.

It's a formula for a plant that runs smoothly and in consistent permit compliance while sustaining an exceptional level of cleanliness that visitors routinely notice. The team is also methodically upgrading a 150-mile collections system and steadily driving down I&I.

These and other accomplishments earned the plant, owned by the Rock Creek Public Sewer District, a 2015 Plant of the Year award in the Small Facility Division from the Missouri Water Environment Association. It was the district's second such award (the first was in 2009). The district won the 2010 MWEA Biosolids Management Award and the 2015 George W. Burke Safety Award from the Water Environment Federation.

"As a district we try to promote a good morale, and as management we listen to any concerns the team members have," says Jason Seger, operations manager. "I like to refer to us as one big family. We've all been here a lot of years, and we spend more time together than with our own families. We have our up days and down days, but we all care about each other, and we've got each other's backs. You can see that on a day-in, day-out basis."

## FAR-FLUNG BORDERS

The Rock Creek District, about 20 miles south of St. Louis on Interstate 55, was formed in the 1980s. "We were approached by Department of Natural Resources in 1999 to consolidate two privately owned sewer companies," Seger says. "At that point, we went from 800 customers to 8,000 pretty much overnight."

Several old package plants were closed, and the flow was rerouted to the Kimmswick plant. In the bargain, the district inherited a large amount of



The award-winning Kimmswick Wastewater Treatment Facility maintains an exceptional level of cleanliness.

old clay pipe that has been the target of an aggressive CIPP lining program. Today, the district covers 32 square miles, serving the cities of Kimmswick and Imperial, and parts of Arnold and High Ridge. A small pump station is located in Festus.

The treatment plant, built in 2004, replaced 11 older activated sludge package plants, the largest a 1.5 mgd facility. The new plant has a 4.8 mgd design flow and treats 1.9 mgd on average using a continuous-flow sequencing batch reactor (Sanitaire - a Xylem Brand).

Wastewater enters a 50-foot-deep pump station, from which six submersible pumps (Flygt - a Xylem Brand) deliver it to a fine screen (Lakeside Equipment Corporation). The flow then passes through an aerated grit basin (Walker Process Equipment, A Div. of McNish Corp.) before entering a splitter box that delivers it equally to four aeration basins.

"The flow goes into the basins continuously, 24 hours a day," says Seger. "Our cycle is 4.8 hours. We have an aeration phase and a mixing phase. We have Flygt mixers in each basin for nitrogen and phosphorus removal. Then we go into a settling phase, followed by decant. We have one basin decanting at all times."





Plant team members (from right) Jason Seger, Mike Mudra and Brian Koester work with the gravity belt thickener (Alfa Laval Ashbrook Simon-Hartley).

“A wastewater treatment plant is not a mom-and-pop shop where you hire your cousin and your brother. We need trained and certified people who can represent the district well.”

JASON SEGER

Air is delivered to fine-bubble diffusers by three 100 hp blowers (Gardner Denver), two in operation at any given time and one reserved as backup. SBR effluent discharges to the Mississippi River. In April through October, effluent is pumped up to a TrojanUV3000Plus disinfection system (TrojanUV) before discharge. In other months the effluent is discharged by gravity flow to the river.

“We have some elevation issues being close to the river,” Seger says. “We were built up on 20 feet of dredged river sand to get above the 500-year floodplain. We didn’t have any room to make the UV system work by gravity, so during the disinfection season we have to pump the effluent up to the disinfection building.”

### SOLIDS SIDE

Waste activated sludge is delivered to a holding tank. When the tank is full (about one week), the material is fed at 0.7 to 0.9 percent solids to a gravity belt thickener (Alfa Laval Ashbrook Simon-Hartley). The thickened material, at 2.5 to 3 percent solids, is sent to three aerobic digesters in series, each holding 330,000 gallons.

Digester 3 has a submersible pump that sends the material to the waste activated sludge lift station for feeding back through the thickener, which

## Kimmswick Wastewater Treatment Facility, Rock Creek Public Sewer District, Arnold, Missouri



BUILT: | 2004

POPULATION SERVED: | 11,500 connections

SERVICE AREA: | Cities of Kimmswick and Imperial, parts of Arnold and High Ridge

EMPLOYEES: | 8

FLOWS: | 4.8 mgd design, 1.9 mgd average

TREATMENT LEVEL: | Secondary

TREATMENT PROCESS: | Continuous-flow sequencing batch reactor

RECEIVING WATER: | Mississippi River

BIOSOLIDS: | Land-applied

ANNUAL BUDGET: | \$1.8 million (operations)

WEBSITE: | [www.rockcreekpsd.com](http://www.rockcreekpsd.com)

GPS COORDINATES: | Latitude: 38°22'1.67"N; longitude: 90°21'40.95"W





### Kimmswick Wastewater Treatment Facility PERMIT AND PERFORMANCE

	INFLUENT	EFFLUENT	PERMIT
<b>BOD</b>	140-150 mg/L	6 mg/L	45 mg/L weekly avg. 30 mg/L monthly avg.
<b>TSS</b>	140-160 mg/L	2 mg/L	45 mg/L weekly avg. 30 mg/L monthly avg.
<b>Ammonia</b>	N/A	0.3 mg/L	Monitor
<b>Fecal coliform</b>	N/A		1,030 cfu/100 mL weekly avg. 206 cfu/100 mL monthly avg.

yields product at 5 percent solids for land application. “We upgraded our solids facility in 2009,” Seger says. “We have a Jetch aeration system with a mixer and blowers. We were spending \$110,000 to \$115,000 hauling 3 percent solids. By getting up to 5 percent, we’ve cut that back to about \$75,000.”

Contractor Midwest Injection hauls the biosolids and applies it on a nearby 90-acre farm that grows corn and soybeans. Annual volume is about 250 dry tons.

### PARTS ON HAND

Seger leads a team of three plant operators (Class C license holders Alex Portwood and Scott Sabo, and Class A licensee Jason Nance) and four maintenance specialists (Class A licensees Mike Mudra and Brian Koester, Class D licensee Paul Luther, and Dave Lanter).

The team takes pride in good housekeeping at the plant, and the MWEA awards program evaluator took notice. “He said he had never seen a wastewater treatment plant so clean, so focused on safety, and with everything working correctly,” Seger recalls.

The Rock Creek Public Sewer District team includes, from left, Dave Lanter, Mike Mudra, Paul Luther, Jason Nance, Brian Koester, Alex Portwood, Scott Sabo and Jason Seger, operations manager.

“As a district we try to promote a good morale, and as management we listen to any concerns the team members have. I like to refer to us as one big family.”

**JASON SEGER**

“Our approach is that if you have a plant where everything is a mess, then people who come out — DNR staff or tour groups — will assume that the effluent is a mess, as well. Our philosophy is to maintain good housekeeping. The team members take a lot of pride. Whether it’s cutting the grass, pulling weeds or picking up after themselves, they treat it like their homes. The operators take care of the buildings, hosing them down and keeping everything clean. The maintenance people keep the garage clean. It’s an ‘everybody cares’ atmosphere.”

On the maintenance side, an extensive planned maintenance program is built around a JOB Cal computerized maintenance management system (Hach). “We have everything on the software,” Seger says. “The system generates work orders, and I distribute them. The maintenance team also does an impeccable job seeing or hearing anything suspicious and acting accordingly.” The program includes vibration analysis as part of predictive maintenance on the blowers.

*(continued)*





# ARSENIC IS **NOT** A GAME

## Ready to make the right move?

AdEdge is your one-stop resource for arsenic treatment systems for any size community. We now supply Bayoxide E33 adsorptive media and E33 media replacements for the largest and the smallest systems. As always, AdEdge offers competitive pricing, experienced engineers, and unparalleled support.

With AdEdge's arsenic treatment systems' global success history, why would you go anywhere else?

When you're ready to make the right move, call us at **866.823.3343**.



[www.AdEdgetech.com](http://www.AdEdgetech.com)

**ACE**<sup>17</sup>  
Booth 1042



The large spare parts inventory provides insurance against long spells of unplanned downtime.

“A couple of years ago, we looked at every piece of critical equipment,” Seger says. “Take the fine screen for example. The gear reducer is a major component for that screen. If the gear reducer went down, it would take about two months to get a replacement. In that time, somebody would have to be here 24 hours a day with a manual rake.

“We keep a booster pump for our gravity belt thickener because if that would go out and the haulers were here, well, you know the rest. If we knew a part could go out and we couldn’t get that part for a week or two, then we needed to have it here.” The parts inventory also includes fuses for the decanter, impellers for the biosolids pump, motors for the motorized air valves for the SBR, and assorted switches, belts and other routine items.

## UPGRADING THE PIPING

Effective maintenance isn’t limited to the plant. The team is steadily improving the collections system and some 5,000 manholes. In 2009, the district completed a systemwide manhole inspection and smoke tested the entire collections system.

Manholes were graded on a scale from 1 (best condition) to 5 to establish repair priorities. “For manhole rehabilitation we use a technology called SpectraShield,” says Seger. “We used to do spot repairs like band seals or chemical grouting, but we learned that once the water table rose, we were more or less pushing the defects to different areas of the manhole.

“So we asked: What can we do to rehab these manholes and walk away? SpectraShield is that product. It’s spray-applied in layers to about an inch thick. They line it from top to bottom, and we get a 10-year guarantee. Once that manhole is lined, we’re done with it for a long time.” As for the piping, the district contracts for CIPP lining at a rate of about 1,500 to 2,000 feet per year.

## ON CAMERA

Visual inspection is a key part of the Rock Creek Public Sewer District’s collections system rehabilitation program. The district owns a van-based mainline inspection system (Aries Industries) along with two Aries push cameras for inspecting private laterals.

The lateral inspection program is among the first of its kind in Missouri, notes Jason Seger, operations manager for the district. “We enacted an ordinance so that anytime a home transfers ownership, we have the right to go in and TV the private lateral,” Seger says.

“We found, after spending upwards of \$4 million on our collections system, that we were still having surcharged manholes. I read in different publications that up to 50 or 60 percent of the I&I can come from the private side.

“So now, anytime a home changes ownership, we work with the title company, and before they can close on that home, we have to inspect the lateral. If the lateral is cracked or loose, if we can see traces of infiltration, or if the sump pump is hooked up to the lateral, the owners have 60 days to get that repaired, at their cost.”

The district’s experience is that when a lateral needs repair, the home buyer and seller have a relatively easy time negotiating the cost into the transaction. “At the end of the day it’s helping them, and it’s helping us as well,” Seger says. “We’re taking care of the whole collections system, private and public.”

Jason Seger, operations manager, believes good housekeeping reflects the dedication to the quality of the effluent.

*(continued)*





# Our experience and knowledge elevates us heads and shoulders above the competition.

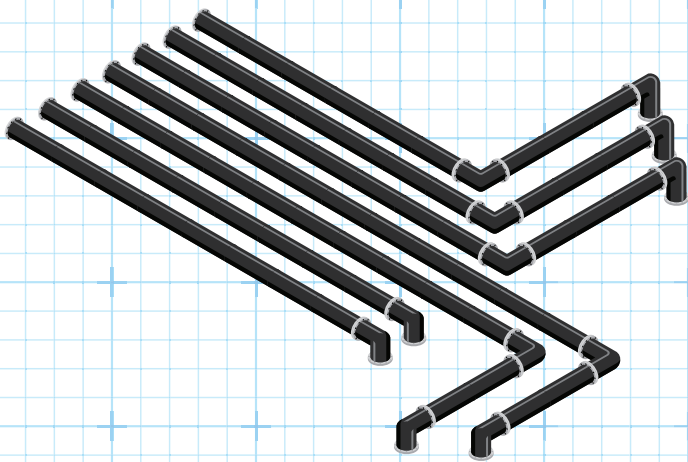

**US**

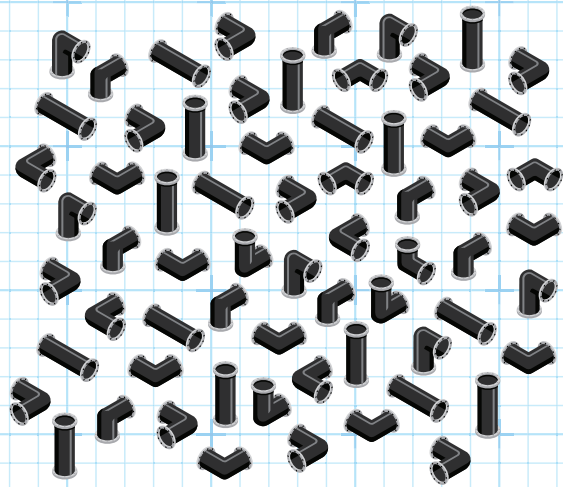

**THEM**

## FITTING SOLUTIONS FOR BYPASSES OF ALL SHAPES AND SIZES

When it comes to fluid handling, sometimes more simply is better. More projects. More experience. More variety. Whether for a pipe-only project or a more traditional sewer bypass, we rise to the challenge, delivering right-sized solutions for your application. From engineered design to on-site setup, management and teardown, we've got you covered. For your next project, turn to the experts who can offer you more.

**24/7 EMERGENCY RESPONSE | 800-736-2504 | [SUNBELTRENTALS.COM](http://SUNBELTRENTALS.COM)**

FREE INFO - SEE ADVERTISER INDEX





Collection system improvement is a priority for the Rock Creek district. Alex Portwood works in a mainline sewer inspection van equipped with a CCTV system (Aries Industries).



“The team members take a lot of pride. Whether it’s cutting the grass ... or picking up after themselves, they treat [the plant] like their homes.”

**JASON SEGER**

“We pride ourselves on training and education,” Seger says. “A wastewater treatment plant is not a mom-and-pop shop where you hire your cousin and your brother. We need trained and certified people who can represent the district well.” In line with that, the district encourages team members to earn progressively higher licenses and pays for their training and testing.

As for the recognition from the MWEA, “It means a lot to me personally, and it means a lot to our crew. I could commend the guys on multiple things, but especially their diversity. They can do anything out here as well as anybody. I sit here and hand out work orders, but the crew is what makes this organization work. Management is like the car. The crew here is the engine that drives it.” tpo

The results have been noticeable. “I can remember when we would reach 14 to 15 mgd at the plant after rain events,” says Seger, who has been with the district for 16 years. “We had a huge rain last August, and again in September, and the plant never saw more than 8 mgd. We never had a permit violation, and we never washed out solids. Even a few years ago, when it wasn’t uncommon to get 8 to 12 mgd in a rain event, the SBR would handle the flow relatively well. It never got to the point where we failed a test. We were still meeting the permit.”

### STAYING SHARP

One reason behind the plant’s performance is a supportive administration and district board, Seger says. Don Daniel, MBA, district administrator, is supported by Annette Hastings, office manager, and Denee Welch, accounts receivable.

“I can tell you the board members do whatever they can to give us the resources to stay within our effluent limitations and keep the environment clean,” Seger says. “They give us resources to deploy where they can be most effectively used.”

A well-educated and credentialed staff also supports performance excellence. Seger himself values education. He started his career in 2000 by taking wastewater operator training at the Environmental Resource Training Center at Southern Illinois University Edwardsville. He has since earned a bachelor’s degree in business administration from Columbia College and a master’s in public administration from Lindenwood University.

### featured products from:

**Alfa Laval Ashbrook  
Simon-Hartley**  
866/253-2528  
www.alfalaval.us

**Aries Industries, Inc.**  
800/234-7205  
www.ariesindustries.com

**Flygt - a Xylem Brand**  
855/995-4261  
www.xylem.com/pumping

**Gardner Denver Inc.**  
866/376-8181  
www.gardnerdenver.com/  
gdproducts  
(See ad page 61)

**Hach**  
800/227-4224  
www.hach.com  
(See ad page 5)

**Jetech, Inc.**  
269/965-6311  
www.jetech.com

**Lakeside Equipment Corporation**  
630/837-5640  
www.lakeside-equipment.com  
(See ad page 3)

**Sanitaire - a Xylem Brand**  
855/995-4261  
www.xylem.com/treatment

**SpectraShield Liner Systems**  
800/284-2030  
www.spectrashield.com

**TrojanUV**  
888/220-6118  
www.trojanuv.com

**Walker Process Equipment,  
A Div. of McNish Corp.**  
800/992-5537  
www.walker-process.com  
(See ad page 87)



# Are You Looking For Easy Maintenance Flame Arresters?

[www.ljtechnologies.com/arrester](http://www.ljtechnologies.com/arrester)



## SPIRAL VS SQUARE



- Spiral wound technology allows for a straight through vapor path for less clogging and reduced pressure drop.
- Removable arrester core (Tube Bank) to facilitate easier inspection, cleaning, and/or replacement.
- Core is of unitized construction, which ensures flame quenching capability.
- Wide range of material construction; Aluminum, 304SS, and 316SS.
- Vertical & Horizontal Configurations.
- Easy removal versus drawer type that can potentially seize inside the housing when closed.
- Can provide taps for temperature sensor mounting.
- Can incorporate Proximity Switch for Flame Trap Assembly for notification of thermal valve pallet closing.
- Factory Mutual/ATEX Approvals in 2" through 12" sizes.

The Shand and Jurs Model 97570 is a combination of our 94020 Conservation Vent and 94306 Flame Arrester in a single, easy to configure package providing for pressure and vacuum relief, as well as positive flame stop on low pressure digesters gas systems.

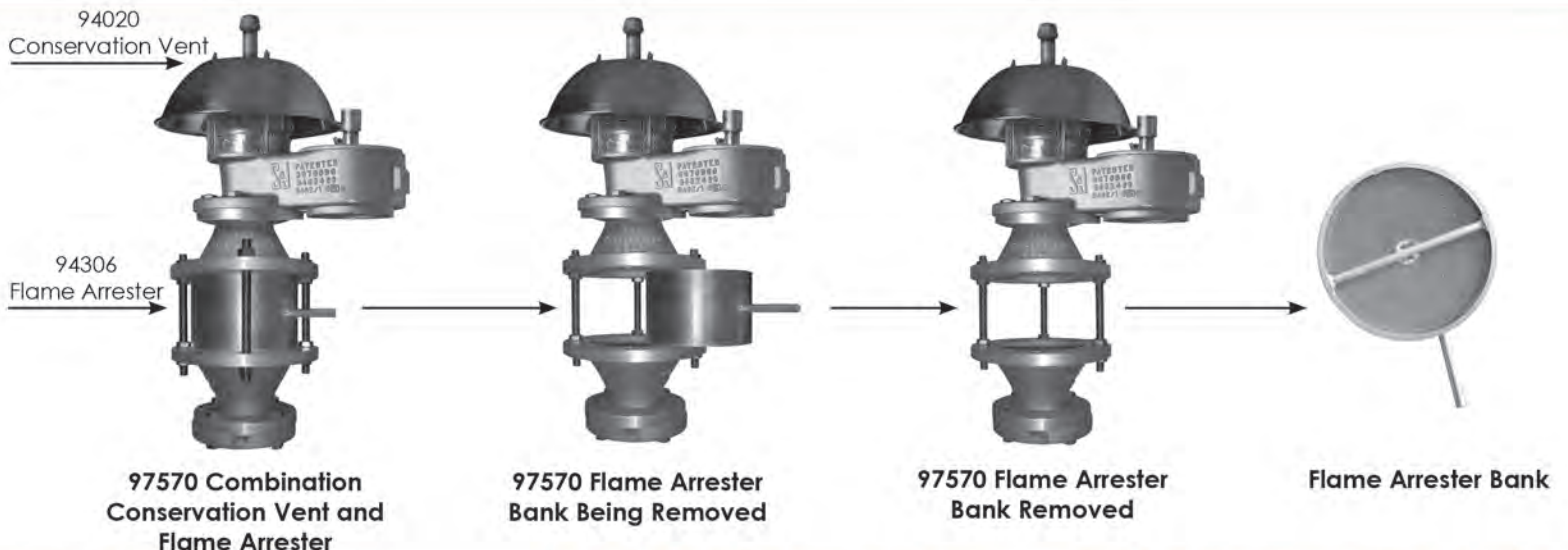



# Catch the Vibe!

FALLING COSTS AND GREATER SIMPLICITY IN VIBRATION MONITORING SYSTEMS ENABLE PLANT OPERATORS TO DO PREDICTIVE MAINTENANCE ON HIGH-VALUE AND BASIC EQUIPMENT

By Chris Hansford

Water and wastewater plant maintenance has undergone a revolution. Operators have moved from routinely servicing machinery at predetermined intervals regardless of condition to applying predictive maintenance.

Until recently, costly and complex technology and low awareness of alternative solutions have limited predictive maintenance to large or high-value filtration and treatment systems. Now, the falling price of technology makes it easier than ever to monitor the operating condition of more basic yet still critical assets such as pumps, motors and fans.

Vibration is a classic indicator of wear, imbalance or misalignment in shafts, bearings and other rotating parts. There are two key advantages to vibration monitoring for detecting wear rates or changes in operating conditions over time. First, it provides information that helps engineers determine if and when essential maintenance will be required. Second, it lets them easily identify at an early stage the exact component where a fault is developing.

Work can then be planned at the most appropriate time, and replacement parts can be ordered only when actually needed. This helps reduce stocking of spare parts and, more important, eliminates unplanned downtime, minimizes maintenance costs, extends service intervals, and prolongs asset operating life.

## SENSOR TYPES

Accelerometers are the most widely used tool for detecting changes in vibration levels. An accelerometer incorporates a piezoelectric crystal bonded to a mass. Under an accelerating force such as vibration, the mass compresses the crystal and generates an electrical signal directly proportional to the force applied. This signal, once amplified and conditioned, can then be used by data acquisition or control systems.

Accelerometers fall into two categories: AC and 4-20mA. While both work on the same principle, AC accelerometers are typically used with data collectors for routine or periodic monitoring of assets, while 4-20mA devices are normally used with PLCs to provide the option of continuous monitoring and remote data capture. Both can detect imbalance, bearing condition and misalignment, but AC accelerometers can also identify cavitation, looseness, gear defects and belt problems.

## GAINING ACCEPTANCE

As maintenance and plant engineers increasingly favor prevention over cure, techniques such as vibration monitoring are being used more widely,

and that trend is likely to continue. A recent report from MarketsandMarkets, for example, estimated that global demand for vibration monitoring systems will reach nearly \$1.5 billion by 2020, a compound annual growth rate of more than 6.5 percent.

This growth is being driven in part by the relatively low cost of vibration sensors. With their compact size and simplicity of installation, sensors can now be fitted to almost every water and wastewater plant asset, no matter how small. Similarly, it is now much easier to fit multiple sensors to larger, more complex filtration or treatment systems. The challenge is how best to manage the large volumes of data generated and use it to run an efficient maintenance program.

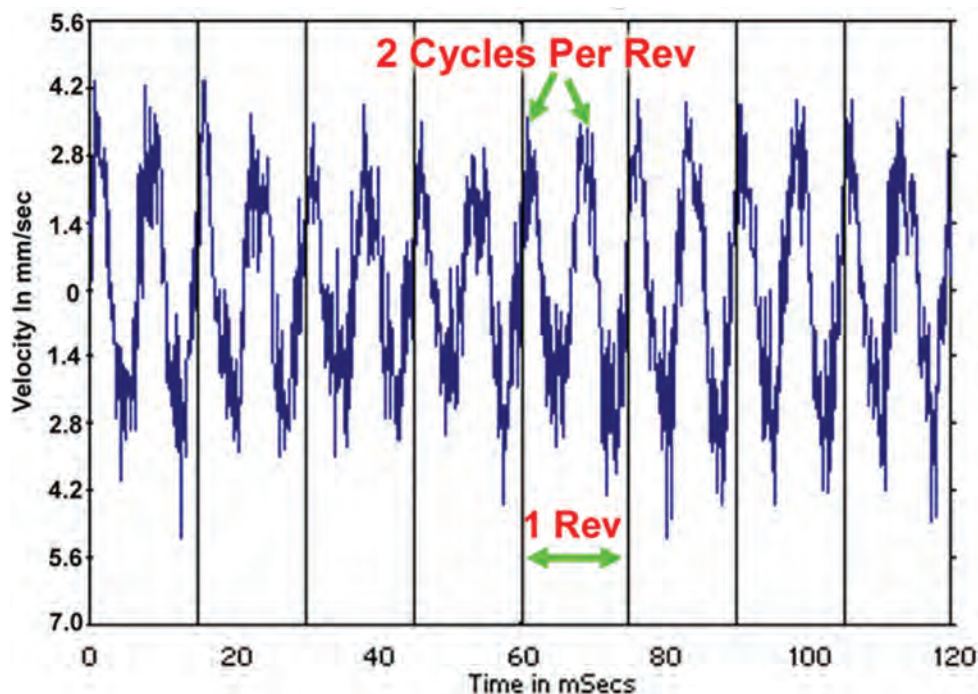

Vibration signatures from equipment help operators detect equipment operating out of specification so that repairs can be made before a failure occurs.

Data can be gathered in two ways:

- Offline, usually with a hand-held data collection instrument that interrogates a permanently fixed sensor or simply uses a hand-mounted accelerometer temporarily positioned on, for example, a motor or pump casing.
- Online, where data is automatically transferred to a centralized control system for real-time monitoring. Though more expensive, this method is generally more reliable and efficient.



For offline monitoring, maintenance teams must develop the most efficient data collection route through the plant. This is normally determined by the criticality of equipment: The most essential assets are checked more frequently than those of lower importance. The maintenance route is programmed into the data collector to guide each operator through the correct routine.

Online and offline techniques can be combined. For example, it may be appropriate for high-value assets to be continuously monitored with a direct link back to a local or remote control center, while lower-value assets are monitored offline at set intervals.

### ANALYZING DATA

Regardless how data is captured, it is critical to analyze the correct frequency spectra. These are dictated by the fault frequencies of the fastest-turning component or components in the machinery being monitored.



Vibration sensors (accelerometers) must be mounted correctly in order to yield useful information about machine operating conditions. They can detect conditions such as imbalance, bearing wear, misalignment, cavitation, looseness, gear defects and belt problems.

A slow-turning sludge scraper system, for example, will have a narrower and lower frequency spectrum than a high-speed blower fan. Once the range of frequencies is known, the measurement resolution is set within the vibration software for spectrum analysis so that the fault frequencies of rotating components are correctly isolated and not, for example, mistaken for natural background machine resonance.

Correctly recorded and analyzed data can play an important role in plant efficiency. Readings from an aeration blower fan, for instance, may reveal that the bearings were incorrectly aligned during installation, that an out-board bearing was never locked down correctly, or that grid couplers are incorrectly lubricated.

The results of an inspection can also throw up surprises. For example, a vibrating blower fan may suggest that the rotor needs balancing, while in reality the vibration could be caused by an unrelated issue, such as the buildup of debris on the fan blades. In each case, the simple process of monitoring vibration levels will allow a potential fault to be identified and rectified before it causes a larger problem.

### DEPLOYING WITH CARE

Finally, it's important to recognize that an accelerometer will only produce accurate and repeatable measurements if mounted correctly. This is especially true of temporarily positioned or hand-held sensors, where users must take care to mount each device onto a flat, smooth, unpainted surface

# AllMax Software can save you time and make your job easier!

## Contact us today to find out *how*.



Antero™  
Maintenance



Operator10®  
Water & Wastewater



Synexus™  
Pretreatment

# AllMax

Software

[www.allmaxsoftware.com](http://www.allmaxsoftware.com)

800-670-1867

[sales@allmaxsoftware.com](mailto:sales@allmaxsoftware.com)

FREE INFO - SEE ADVERTISER INDEX

that is wider than the base of the accelerometer itself.

The surface should also be free of grease, oil or other contaminants, be close to the source of vibration, and be perpendicular to the axis of rotation. Standard accelerometers normally record vibration in one axis, although compact versions are available for measuring vibration in two or three axes simultaneously.

Although vibration monitoring may not always be seen as the most important maintenance option, the growing need to maximize uptime and extend the operating life of all plant assets makes this measurement technique an increasingly valuable weapon in the water and wastewater plant operator's armory.

#### ABOUT THE AUTHOR

Chris Hansford is managing director of Hansford Sensors, a manufacturer of vibration and condition monitoring devices based in the U.K. **tpo**



# MAGNIFICENT MENTOR

KEN BURGNER SHARES HIS LOVE OF SCIENCE AND THE CLEAN-WATER PROFESSION WITH STUDENTS WHO REPRESENT THE NEXT GENERATION OF OPERATORS AND LAB TECHNICIANS

STORY: **Jim Force** | PHOTOGRAPHY: **Sallie Shatz**

KEN BURGNER WAS PROUD TO LEARN THAT A STUDENT HE HAD mentored had won a prestigious award in the Intel International Science and Engineering Fair in June 2015.

For her work on aquaponics, 10th-grader Stephanie Vaughn won a water technology award and a \$1,000 cash prize, presented by the Saudi Arabian King Abdul-Aziz & His Companions Foundation, for Giftedness and Creativity. Her project showed that invasive plants could be used to reduce nutrients in wastewater and indicated that biofuels could be extracted from the water hyacinths and water lettuce grown in her experiment.

It was one of the high points in Burgener's work with students during his tenure as laboratory director at North Davis Sewer District in Syracuse, Utah, near Salt Lake City.

"When I started in the profession, I realized the importance of working with the next generation to help them understand the importance of wastewater treatment," he says. The science fairs have been a perfect way to make the connection between the students' curiosity and clean water, he believes.

For his more than 25 years of teaching and mentoring thousands of young people, Burgener received the 2016 Water Environment Federation Individual Public Communication and Outreach Award. He received a similar honor from the state of Utah earlier in the year.

Burgener believes the best way to educate the public is through students: "The public needs greater awareness of the importance of water and wastewater treatment, and our global responsibility to these professions," he says. "We can't do what we do without the public. But I feel that we can



Ken Burgener, laboratory director at the North Davis Sewer District, Syracuse, Utah

have a greater impact on students than we usually can with their parents."

## GETTING STARTED

After earning a bachelor's degree in horticulture and a master's in agronomy from Brigham Young University, Burgener joined the clean-water profession as laboratory director at St. George, Utah, in the early 1990s. That's where his public education "itch" got started: "I began to realize the importance of working with students, especially at science fairs."

When he moved to the lab at North Davis, he began working with universities, recruiting students from nearby Weber State and Brigham Young as interns. "We had 11 interns over the years, and most of them went on to productive careers in science, working in companies, as medical doctors, or with the Centers for Disease Control. It's kind of neat seeing these kids do well in their careers."

Burgener also organized and conducted student tours of the treatment facilities and struck up close relationships with schools. "That started in 2008," he says. "Now the school districts are looking for significant science projects for the students and contacting me, recommending kids and sending them to me. We sit down and discuss their interests and come up with projects."

The impressive list of projects includes topics such as *E. coli*, viruses and energy recovery in waste treatment. In addition to Stephanie Vaughn's project, Burgener mentored Jed Donald Grow and Andrew Quinn Ross of Clearfield High School, who won the Ricoh Sustainable Development Award at the Intel Science Fair in 2013 for research on





“When I started in the profession, I realized the importance of working with the next generation to help them understand the importance of wastewater treatment.”

**KEN BURGNER**



Burgener has recruited 11 interns since he joined the lab at the North Davis district. He enjoys working with students as they progress to productive careers.

Burgener is passionate about education. He talks to students about the science of wastewater treatment and demonstrates its value with real-world examples.

## Ken Burgener, North Davis Sewer District, Syracuse, Utah

POSITION: | **Laboratory director**

EXPERIENCE: | **25 years**

RESPONSIBILITIES: | **Manage compliance sampling and analysis; supervise four lab technicians**

EDUCATION: | **Bachelor's degree in horticulture, master's in agronomy, Brigham Young University**

CERTIFICATION: | **Grade 4 (highest) wastewater operator**

RECENT AWARDS: | **2016 WEF Individual Public Communication and Outreach Award, 2016; 2016 Utah Public Education and Awareness Award**

GOALS: | **Increase public awareness of the importance of water and wastewater treatment**

GPS COORDINATES: | **Latitude: 41°5'0.16"N;  
Longitude: 112°6'37.12"W**





## EMPHASIS ON EDUCATION

Ken Burgener has logged over 25 years in the clean-water profession, 21 as laboratory director of the North Davis Sewer District.

He has served as chairman and as a member of the Water Environment Association of Utah (WEAU) Laboratory Committee and other WEAU committees, and has been inducted into the 5S (Select Society of Sanitary Sludge Shovelers) for his service. In 2002 he received the Water Environment Federation Laboratory Analyst Excellence Award. During his tenure, North Davis has been named WEAU's Outstanding Laboratory six times.

On the public education side, his WEF communication and outreach cited him for:

- Judging and advising for many science fairs at elementary, junior high and high schools.
- Developing and administering WEAU's annual \$1,000 donation to the Science and STEM Fairs of the state of Utah for science fair winners with projects related to water.
- A booth at STEM job fairs to encourage students to pursue science-based careers.
- Serving as mentor and adviser to local and national science fair entrants. Award-winning students have used the North Davis lab and other facilities to work on their projects.
- Setting up aquariums, aquaponics demonstrations, displays and posters at the plant to help tour groups understand microbiology and wastewater treatment.
- Promoting the lab and treatment plant for tours and education.

Burgener has been the WEAU Public Education Committee chairman for many years and has administered the Stockholm Junior Water Prize competition. He says he is a true "science geek," and proud of it.



Students tour the North Davis Sewer District facility. As part of the visits they take part in presentations and discussions on the importance of water and its treatment.

acquisition of bioelectricity from wastewater, with applications for hydrogen generation. "It was a significant award — \$12,500," Burgener says.

### TOUR IN DEPTH

Many treatment plants offer tours, but Burgener's involve more than just a view or two from the catwalk. He gives students things to relate to, things to remember. When they arrive, they meet with Burgener in the media room, equipped to show videos and slide presentations.

Burgener makes sure his presentations are current and the topics relevant. "Teachers like discussions on current topics; it makes them want to come back," he says. "Cyanobacteria has been in the news lately, so I say, 'Come on out and let's really talk about cyanobacteria.'" The plant has an aquarium: Kids understand the idea of clean water when they see the fish swimming around. The aquarium cost about \$1,000 — well worth it in Burgener's view.

Then there's Penelope the dinosaur. Burgener uses her to explain that the kids today are drinking "dinosaur water" — water that has been around since the earliest times on Earth. At that point, of course, the students learn about the water cycle.

Ken Burgener uses a display in the district headquarters to show young people things that should not be flushed into the wastewater system.





Burgener maintains a working fuel cell in the media room. It's a previous student's project and illustrates the scientific nature of water and wastewater treatment. "We try to get the kids past the yuck factor," Burgener says. "We pique their interest, and it causes them to think. They come away with a different kind of feeling."

The tours take about two hours, and the groups are limited to 30 students. Operators help with the treatment plant side of the visits. "We have one group at the plant, and another in the lab," Burgener says. "Then we shift. If we had more time, we would conduct more tours. The peak year was 2013, when 3,000 to 4,000 kids went through and the plant team sometimes gave two to three tours a day."

### THE SCIENCE SIDE

Kevin Cowan, NDSD director, observes, "Ken eats, drinks and sleeps science. It's his hobby as well as his profession." So it's no surprise that Burgener stresses the science of wastewater treatment.

"People don't think about wastewater having a lot of science associated with it," he says. "But we use as much science as any industry out there. Physics, chemistry, biology, agronomy — wastewater has it all."

“We try to get the kids past the yuck factor. We pique their interest, and it causes them to think. They come away with a different kind of feeling.”

**KEN BURGNER**

In his locale, kids know about rocket fuel but few realize that at the wastewater plant, the waste from local rocket fuel production has to be treated. "At first, kids are curious, even disbelieving, but when you talk it through and tell them how exciting it is, they understand," Burgener says.

Much of what he talks about connects to the students' classroom experience: "Biology, math, protozoans, metazoans, aquaponics, nutrients. It's all part of the STEM curriculum [science, technology, engineering and math]. Students love to see real-world examples."

### SOURCE OF INSPIRATION

What inspired Burgener to be so passionate about education? He recalls a professor at the University of Utah talking about endocrine disruptors. "He opened my eyes about why we needed to be talking about this to the public," he says.

And what about the state of public education in the wastewater field? "Honestly, I'd have to give us a grade C or D. I find most people in wastewater just don't do a good job of reaching out and talking about what we're doing. Flush it and forget it is just not real life. We need to be constantly talking about wastewater treatment as a positive, not a negative. Compared to Third-World countries, we're pretty well-off here, but we can't be complacent. Instead of withdrawing, we need to go out and be proactive."

Burgener is grateful for the support of the local wastewater board, and from Cowan: "Our board chair wanted to have interns. You need people who sup-

port you, who understand what you're doing. The future depends on how we educate our students." If that is done right, he maintains, it will be easier to generate support for the profession in the future.

Cowan says Burgener's public education work has had a positive impact on the district. "He loves his job and loves to tell people about it," Cowan says. "He's facilitating the story that our district is going green."

Burgener's recent projects include helping a student develop a science project dealing with the impact of waste on a local natural area. "We have a popular hiking canyon nearby," he says. "But it gets a lot of pet waste and even human waste. The student wants to study the impact of those wastes on the natural environment."

Who knows which student's projects will be next to win accolades on an international stage? **tpo**

## Red Valve® An Extra Dose of Protection for Your Community.



**Introducing the Dechlorinating Overflow Security Assembly (DOSA), an innovative system for water tank overflow and drain pipes.**

The non-clogging DOSA Overflow Pipe Assembly prevents intrusion of birds, rodents, insects and cold air drafts, increases tank security and automatically removes chlorine residuals during discharges. DOSA is constructed of dual Tideflex® Nozzles and an internal adjustable dechlorination tube, completely encased in an epoxy coated steel or stainless steel body. Call us today to learn more.

Tideflex® Check Valves



Tideflex® Standpipe Mixing System



Tideflex® Reservoir Mixing System

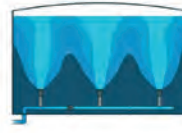

Tideflex® Elevated Tank Mixing System



Red Valve Company, Inc.



[www.redvalve.com](http://www.redvalve.com) | 412.279.0044

FREE INFO - SEE ADVERTISER INDEX





A covey of seven quail approaches a feeder in the grassland that was created at the Phillips Street Water Treatment Plant.

## Growing Diversity

A CONSTRUCTED GRASSLAND ON WATER PLANT SITE THAT WAS ONCE A FARM IS NOW HOME TO ABUNDANT NATIVE PLANTS AND A RICH VARIETY OF WILDLIFE

By Jeff Smith

Creating a field of native grasses, wildflowers and trees to attract nesting birds and other wildlife has been rewarding for operators of Indiana American Water's Phillips Street Water Treatment Plant near Kokomo, Indiana.

Since 2007, when the 2 mgd treatment plant was built on the site of a former dairy farm, species including quail, red-winged blackbirds, warblers, grasshopper sparrows, killdeer and other birds have established nests and thrive on the constructed grassland habitat. Bright-colored wildflowers such as the yellow snakeroot attract pollinating honeybees and butterflies. Plenty of grasshoppers, crickets and other insects provide food for the birds.

The treatment plant, its backwash pond and residuals lagoon occupy 9 acres of the 67-acre site, nearly 2 miles from town. The facility's wellfields are scattered over the remaining 56 acres of the once dormant farmland, which is now a grassland.

"We could have farmed it out or made it into one big field of grass that would require mowing and time to maintain," says Ryan Smith, operations superintendent. "But that would have been labor- and cost-intensive."

Instead, Smith led a team of workers who in two days planted native warm-season grasses, including big bluestem, sideoats grama, prairie dropseed and switchgrass. Wildflowers such as purple-cone flower, black-eyed Susan, prairie dock and wild bergamot were mixed in to provide balance over the entire 56 acres.

Because only a couple of growing seasons had passed since the last harvest on the farmland, no new tilling was required. Mowing the wellfield to reduce the weeds was the only soil preparation before planting.

Smith's team used an 8-foot-wide grass drill with double-disc furrow openers to ensure that the seeds were inserted about an inch below the surface. The heavier wildflower seeds were mixed with the light and fluffy grass seed to provide even distribution of about 6 pounds per acre.

Since the seeds grow down in the first year to establish their roots and then they grow upward slowly, it took patience to get the pay-off. "It took about three years for our grasses and flowers to take effect and for the field to give good cover," says Smith. Other than a rare and very selective controlled burn to remove weeds, no maintenance is required. Normal rainfall provides ample watering.

“We could have farmed it out or made it into one big field of grass that would require mowing and time to maintain. But that would have been labor- and cost-intensive.”

RYAN SMITH

After the grassland root system was well established, Smith's team collaborated with the local chapter of the Hoosier Bobwhite Quail Forever to improve the habitat by planting more than 400 seedlings of deciduous trees, shrubs and pines. Nearly 15 species of greenery now form a fence line and create additional food and cover for game and non-game wildlife.

Several coveys of quail were introduced to the grassland to join other naturally occurring ground-nesting birds and critters. Predators such as hawks, raccoons and fox also took up residence and thrive in the habitat. "After a couple of hatchings over two or three years, we take a dozen or so





The constructed grassland with the Phillips Street Water Treatment Plant shown in the background.

new quail out there to help build up the number of birds,” Smith says.

Recovery of the quail has been slow but positive, says Smith, a member of the local Quail Forever chapter. Operators and maintenance staff who regularly visit the unmanned facility sometimes see quail near the plant filling their gizzards with gravel. “We don’t normally see them flying around, and we’re not going to hunt them, but they are there,” says Smith.

Smith was operations supervisor of the Phillips Street Plant during construction, but has since moved on to become operations superintendent of Indiana American Water’s 10 mgd Noblesville Treatment Plant. But he still stops by the Phillips Street Plant occasionally to make sure the grassland remains healthy. He observes, “It was a good way to give back to Mother Nature and the right thing to do.” **tpo**

**Everyone  
talks about  
creating a  
greener  
environment.**

**You actually *do* it.**

Find the tools you need to keep  
your communities **green** at  
[www.colepublishing.com](http://www.colepublishing.com).

*Publishing environmental trade magazines since 1979.*



**THE  
RUTHMAN  
FAMILY  
OF MANUFACTURERS**

[ruthmancompanies.com/ruthman-companies](http://ruthmancompanies.com/ruthman-companies)

**MUNICIPAL  
VERTICAL TURBINE PUMPS**

**FROM: DEMING®**

**AXIAL FLOW  
LARGE VOLUME PUMPS**

**FROM: FPI™**

**HORIZONTAL AND VERTICAL  
CENTRIFUGAL  
PUMPS**

**FROM: GUSHER®**

**HEAVY DUTY  
SLUDGE & SLURRY  
PUMPS**

**FROM: NAGLE™**

**INDUSTRIAL  
VERTICAL TURBINE PUMPS**

**PROCESS  
FROM: SYSTEMS, INC.™**





A pipe gallery in the Jumping Brook Water Treatment Plant.

# The Old and *the New*

THE JUMPING BROOK WATER TREATMENT PLANT USED TUBE SETTLERS TO DRIVE DOWN TURBIDITY AND EARN A 15-YEAR DIRECTORS AWARD FROM THE PARTNERSHIP FOR SAFE WATER

STORY: **Steve Frank**

PHOTOGRAPHY: **James Robinson**

HIGH-QUALITY DRINKING WATER IS SO TAKEN FOR granted now that it's hard to imagine the lack of good water affecting a Revolutionary War battle.

Sixteen miles northwest of Neptune Township in central New Jersey lies the 1,800-acre Monmouth Battlefield State Park. On June 28, 1778, Gen. George Washington and the Continental Army ambushed the British there and fought them to a standstill.

That may not sound like much to brag about, but it was a turning point in the American Revolution and water played a role. The highly disciplined British army had beaten the Continental Army almost every time. But over

the winter of 1777-'78 at Valley Forge near Philadelphia, Washington's army had drilled and practiced to become a formidable force.

The 11,000-man British army had abandoned Philadelphia, marching northeast across New Jersey to catch transport ships to take them to safety in New York. Washington and his newly trained force harassed the redcoats, burned bridges, and filled wells and creeks with the bodies of horses and soldiers to make the water unusable. The intense summer heat and lack of good water caused men to drop on both sides, but the American Army stiffened and showed the British they could fight.

Now, residents of Monmouth and Ocean counties have plenty of good



water, thanks to the 30 mgd coming from the Jumping Brook Water Treatment Plant in Neptune Township and its sister facility, the 36 mgd Swimming River Water Treatment Plant in Colts Neck. These plants are part of the American Water family of facilities in New Jersey, the largest state in American Water's regulated operations.

In 2016, the Jumping Brook plant, owned by New Jersey American Water, received a 15-year Directors Award from the Partnership for Safe Water.

### SEASONAL DEMAND

Matt Walsh is production supervisor at Jumping Brook, and Patricia Ramsden is manager of what is known as the Coastal North system, which includes the Jumping Brook and Swimming River plants. Walsh comes from a water operations background. He has 25 years in the water business, and is going on 15 years with American Water.

"Between Jumping Brook and Swimming River, we service 366,000 customers," Walsh says. The influx of summer tourists visiting the Jersey shore has a dramatic effect on demand.

The Jumping Brook plant takes its name from the nearby stream running on the property that was used as a raw water supply in the past. The original plant, which dates back to 1901, belonged to Monmouth Consolidated Water. "It was on the same property we now occupy, but in a different location," Walsh says. "Jumping Brook runs out back. The original plant took water from that stream."

### STABLE SOURCE

That stream can't provide nearly enough water now, so the facility buys source water from the New Jersey Water Supply Authority. That water is stored in Glendola Reservoir about a mile and a half from the plant.

"Glendola Reservoir is basically a big tank in the ground. It's pumped storage," says Walsh. "It's in Wall Township and feeds the plant via gravity. We have a limnologist who comes in and does all the analytics on the reservoir. He monitors everything from bacteria to biological growth. He provides information and recommendations for things we can do to maintain source quality."

"We have air blowers in the reservoir. At certain times of the year we'll turn them on and off to help control algae formation and keep the water moving. It's a great advantage. The limnologist is very familiar with our reservoirs. He tells us when we have odor-forming bacteria. By observing temperature and weather, he'll tell us when he thinks that's going to subside."

If the taste and odor become a problem, powdered activated carbon can be fed into the raw water main. "Just recently we installed source water monitoring," Walsh says.

With source water quality under increasing challenges, American Water has installed monitoring capability at all its facilities. The turbidity of raw water coming from the reservoir ranges from 2 to 5 NTU. The water supply authority fills the reservoir on the side opposite of where Jumping Brook takes its raw water feed.

### UPGRADING TECHNOLOGY

"The Jumping Brook plant is unique," says Walsh. "We have what we call the old plant and the new plant. The old plant has two Aldrich purification units that date from the 1960s and can treat about 5 mgd each. In the 1980s, a growing population pushed the plant to expand, and the plant added four solids-contact clarifiers from Infilco Degremont (SUEZ) that can produce 5 mgd each, bringing total capacity to 30 mgd."

"It's tricky when you're an operator here," says Walsh. "You have two different animals to contend with. Both process trains feed into the same clearwell, but they're separate processes."

The Aldrich units are referred to as all-in-one units. They take water into a center ring and mix it with chlorine gas as an oxidizer.

“We have a limnologist who comes in and does all the analytics on the reservoir. He monitors everything from bacteria to biological growth. He provides information and recommendations for things we can do to maintain source quality.”

MATT WALSH

### Jumping Brook Water Treatment Plant, Neptune Township, New Jersey



BUILT: | 1901, expanded 1960s and 1980s

SERVICE AREA: | Monmouth and Ocean counties

CUSTOMERS: | 366,000 (Jumping Brook and Swimming River)

SOURCE WATER: | Glendola Reservoir

TREATMENT PROCESS: | Aldrich purification units, solids-contact clarifiers

GPS COORDINATES: | Latitude: 40°12'16.32"N; longitude: 74° 3'55.57"W

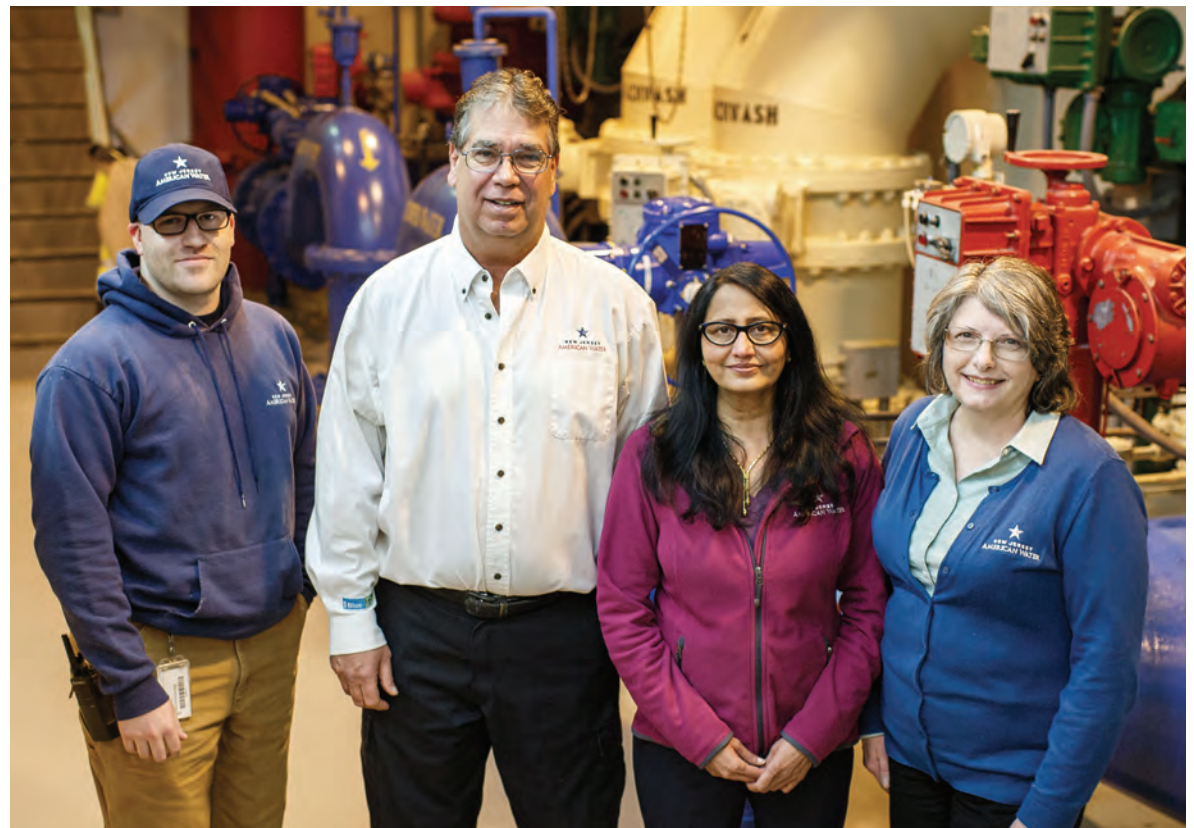

The team at the Jumping Brook treatment plant includes Colin Toon, operator maintenance mechanic; Matt Walsh, production supervisor; Ilaben Patel, specialist water quality/environmental compliance; and Judy Habrack, supervisor water quality/environmental compliance.





Chlorine levels are checked regularly at the facility (titrator by Evoqua Water Technologies).

“We have evaporators,” says Walsh. “We take liquid chlorine and turn it into gaseous chlorine. We feed so much chlorine that, if we were to feed the gas directly off the cylinder, we would freeze the line. We added tube settlers to the purification units. Settled water turbidity was around 1 NTU. With the introduction of the tube settlers, we now have 0.1 NTU.”

“This greatly enhances our filter runtimes and our filter lives. We’re putting a lot less turbid water on top of the filters with the introduction of the tube settlers, so we don’t have to wash the filters as often.”

The four solids-contact filters are in a separate building from the Aldrich units. Walsh describes them as temperamental: “If you quickly increase the flow through them, the solids could spill over onto the top of the filters. You have to be gentle with them.”

Both plants pretreat with chlorine and use polyaluminum chloride as a coagulant. Then they settle solids, adding polymer to speed settling. Going into the clearwell, the water is dosed with chlorine fluoride and a corrosion inhibitor. “We went to chloramines three years ago because of the trihalomethanes,” Walsh says.

### ALWAYS LEARNING

The Jumping Brook and Swimming River plants each have four operators who work rotating shifts to staff their plants 24 hours a day. The two plants are in the same American Water operating unit and work closely together. Six maintenance



The turbidity of raw water coming from the Glendola Reservoir ranges from 2 to 5 NTU. The water leaves the plant at 0.1 NTU.

“ Sometimes (people) think the water falls out of the sky and it miraculously falls into their faucet. But when you sit down with them and you’re enthusiastic, like the majority of our employees are, you can have a conversation with people.”

**MATT WALSH**

mechanics are available to the two plants from 7:30 a.m. to 4 p.m. Monday through Friday.

The plants also share seven operator/maintenance/mechanics who float between them, working rotating 24-hour shifts. They fill in for operators in addition to performing minor maintenance.

Six of the plant operators hold New Jersey T1 (entry-level) water plant operator licenses. Ten hold T2 licenses, three hold T3 licenses, and two hold T4 licenses, the state’s highest level of certification.

The higher certification operators hold, the more training contact hours (TCH) they must get to maintain their licenses. TCH requirements must



be fulfilled every three years. Operators can get some TCHs in-house, but must also go elsewhere for other training.

Because they handle chlorine, the facility is under New Jersey Toxic Catastrophe Prevention Act regulations, which require specialized training for all staff members. Because the facility is not owned by a municipality, it also falls under OSHA rules, and that drives mandatory training. For example, employees must take a 40-hour Hazardous Waste Operations and Emergency Response training course when they start the job and an eight-hour refresher every year.

### STAYING SAFE

Walsh notes that American Water is an extremely safety-conscious company. "I do weekly tailgate talks on safety, and we have a near-miss reports hotline that anybody can call. In addition, everyone has the ability to stop work for safety. If employees see something, they can say something. They know that I care about each and every one of them as persons. They know I want them to go home safe at night.

"It's funny," Walsh adds. "When you wear an American Water shirt and you're out and about in the public, you find that people have questions for

you. Sometimes they think the water falls out of the sky and it miraculously falls into their faucet. But when you sit down with them and you're enthusiastic, like the majority of our employees are, you can have a conversation with people. And by the end of the conversation, they're saying, 'Wow, I didn't know that went on.'" **tpo**

### featured products from:

**Evoqua Water Technologies LLC**  
www.evoqua.com

**SUEZ**  
800/446-1150  
www.degremont-technologies.com

**KOHLER Power Systems**  
800/544-2444  
www.kohlerpower.com

### READY FOR THE WORST

After Hurricane Sandy hit the eastern U.S., Matt Walsh learned a lesson about the need for water treatment plant reliability.

The storm hit in late October 2012. "Our whole beach area, which is a barrier island, was devastated," recalls Walsh, production supervisor at the Jumping Brook Water Treatment Plant. "There were houses in the street. There were services and no houses. It was a big to-do — years of construction. Our water towers survived, but there were no services available. The town was wiped out."

The Jumping Brook and Swimming River water plants were far enough inland to be spared the worst impacts. "We experienced high winds," says Walsh. "We had two small generators and some emergency power, but what we could do with them was limited. We have a natural gas pump and a diesel pump that could supply about 8 million gallons during a power outage. When the power is out for an extended time, we can bring in 30 mgd, but we can only put out 8 mgd."

Recently the plant completed final testing of a 1.75 MW diesel generator (Mitsubishi engine, KOHLER generator). "So now, we can power every one of our pumps in the event of a power outage and put 30 mgd out the door," says Walsh.

Hurricane Irene also affected all of New Jersey and flooded the area of the Swimming River Reservoir. The high water also affected source water quality. But many of American Water's plants are interconnected, and they can cross-support each other.



Are you forced to do more with less?  
So, when do you find time for pump servicing?

PVP Pumps save Time  
and Money. Here's how.

PVP Double Disc Pumps™ operate up to 10 times longer and cost up to 70% less to maintain. When you factor in the total life cycle expense (labor costs, maintenance and repair), you will find PVP's Double Disc Pumps are a better value. Our pumps offer...

- PVP pumps operate at lower speeds with no sacrifice in performance: Lower wear rate = Longer life.
- Our *Maintain-in-Place* design reduces downtime and lowers maintenance costs.
- Seal-less, gland-less, oil-less design lowers operating costs.
- PVP pumps can run dry indefinitely without damage.
- Fewer moving parts means less need for repairs or maintenance.



### The PVP Life Cycle Cost Advantage

Are you operating rotary lobe or progressive cavity pumps? Then you are familiar with their repair and maintenance costs. Penn Valley's Double Disc Pumps employ a non-close tolerance design that provides for an extremely long operating life.

Learn the facts. Contact us today and discover how PVP's positive displacement pumps are your most cost-effective, long-term value.



Toll Free: 800-311-3311 • PennValleyPump.com



# Just One Water

THE NEWLY FORMED WATER ENVIRONMENT & RESEARCH FOUNDATION SETS RESEARCH PRIORITIES THAT FOCUS ON A MORE INTEGRATED APPROACH TO WATER MANAGEMENT

By Ted J. Rulseh

**T**he days of looking at water as separate entities — wastewater, drinking water, groundwater, stormwater — are rapidly fading. Consensus is forming that there’s just one water, that all those sources are connected.

In line with that, a year ago the Water Environment Research Foundation (WERF) and the WateReuse Research Foundation (WRRF) merged to create the Water Environment & Reuse Foundation (WE&RF).

This not-for-profit organization brings together a \$200 million portfolio of research. But now that this new entity exists, where will its research emphasis fall? A key decision-maker is Jeff Mosher, chief research and strategic planning officer.

Mosher has been in the water field since 1990, previously working on regulatory development as a contractor to the U.S. EPA and on science and technology related to water, water quality, and water treatment. For the last 11 years, he served as executive director of the National Water Research Institute. Before that, he worked with the Association of Metropolitan Water Agencies and WRRF. He talked about his new organization’s research priorities in an interview with *Treatment Plant Operator*.

**tpo:** How would you describe the approach WE&RF is taking toward research?

**Mosher:** The purpose of the merger was to approach water in a more integrated way. Water issues are connected. WE&RF is thinking about managing all the water resources within the urban environment more effectively. I believe one outcome is to build more resiliency into water resources management, both on the supply and demand sides, including water for the environment.

“We have an initiative called sustainable integrated water management. That’s where we look at ideas on how to manage water supplies holistically, whether that’s wastewater, stormwater, recycled water or groundwater. It also includes green infrastructure.”

JEFF MOSHER

**tpo:** What criteria are you using to establish research priorities?

**Mosher:** We have taken a two-phase approach. In the first phase, we’ve developed a 2017 research plan integrating the current activities of WERF and WRRF into one research program. That is an interim step.

**tpo:** What does the second phase of research planning look like?

**Mosher:** In the longer term we are undertaking a visioning process to help foresee the future of water supply and water management, and to develop research concepts reflecting that vision. We also plan to reach out to our partners, including our subscribing members. That process may include a crowdsourcing approach where we take our initial ideas and vet them with multiple stakeholders. Based on this interaction and feedback, we’ll develop an updated research program to start in 2018 that reflects the shared views developed in the visioning effort.

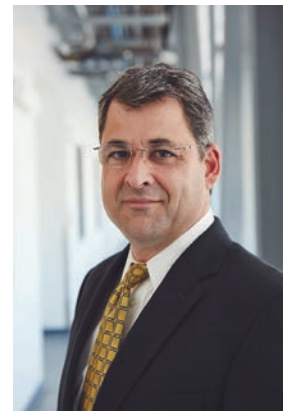

Jeff Mosher

**tpo:** How would you describe WE&RF’s immediate research priorities?

**Mosher:** We’re very interested in resource recovery. For example, we want wastewater utilities to recover water, nutrients and energy. Water reuse, including potable reuse, is a large focus. Also, utilities need to be energy efficient and should consider solar power and other initiatives to integrate renewable energy into treatment facilities. Beyond that, there is real potential for wastewater facilities to become net zero-energy facilities, generating more energy than they use.

**tpo:** What about resource recovery looking beyond energy?

**Mosher:** Nutrient recovery is an important area. We need to remove nutrients from wastewater before discharge to the environment — there are effluent standards for phosphorus and nitrogen — but can we recover those nutrients? And are there other materials in wastewater, such as metals, that can be recovered?

**tpo:** What about research initiatives that take a more holistic view?

**Mosher:** We have an initiative called sustainable integrated water management. That’s where we look at ideas on how to manage water supplies holistically, whether that’s wastewater, stormwater, recycled water or groundwater. It also includes green infrastructure. An example of that is on-site water treatment: collecting water from a building or a district, treating it on site and using it for non-potable



purposes such as flushing toilets. It's a question of transforming how we approach watershed management — integrating it with urban, agriculture, forestry, industrial and others uses.

**tpo: How does stormwater fit into the picture of water reuse?**

**Mosher:** One question is whether we can treat the initial flushes of stormwater that may contain more contamination using things like passive filters. There's also a push for decentralized stormwater capture — collecting stormwater on a city block, storing it underground in a manufactured container, and using it for irrigation or directing it to groundwater recharge.

**tpo: Where does potable reuse fit into the research picture?**

**Mosher:** We have a very strong program on recycled water, and there is tremendous interest in expanding potable reuse in many states. That includes indirect potable reuse where we recharge the water into the ground or use it to augment drinking water reservoirs. There's also a trend toward direct potable reuse, in which the water is not put in an environmental buffer.

**tpo: What are the challenges to attaining widespread adoption of DPR? Cost? Public acceptance? Technology?**

**Mosher:** It is a combination. DPR is not just a treatment process. It's a question of managing the wastewater collection system differently, operating the wastewater plant differently, better monitoring, the use for advanced treatments, and operator training.

**tpo: What is involved in running the collection system differently?**

**Mosher:** If you think about how we manage drinking water, we do source protection. We protect watersheds, reservoirs and rivers to keep pollutants out of the water supply. We can apply similar concepts to managing collection systems by building on our current wastewater pretreatment programs.

**tpo: How would operation of the wastewater treatment plant have to change?**

**Mosher:** Traditionally, wastewater treatment discharge requirements are based on weekly or monthly averages. On the drinking water side we deal in maximums — such as the maximum turbidity coming out of the filters. Those maximums cannot be exceeded. There are ways for wastewater operators to modify their treatment and monitoring. For example, it's possible to put an equalization basin at the end of the treatment process to equalize the water quality before it goes to advanced treatment. They could also run the activated sludge process differently to increase removal of trace organic compounds like pharmaceuticals.

**tpo: What do you observe about public acceptance of DPR?**

**Mosher:** The key is to go out to your stakeholders early and talk to them about the reason why you want to do this. Once they understand the treatment processes and the benefits, you can get a vast majority of a community to support these projects.

**tpo: What areas of research is WE&RF exploring in relation to DPR?**

**Mosher:** We want to better understand the treatment technologies. Part of that is using new and innovative technologies, and innovation is an area where we are very strong. For example, those technologies could be more cost-effective or more energy efficient. Other important aspects are how to monitor and operate the DPR systems.

**tpo: What aspects of monitoring are critical for DPR?**

**Mosher:** We need to monitor for compliance, but also for treatment

performance and reliability. Online monitoring will tell us in near real time that the processes are performing as they should. We want immediate feedback to be available to the operators. So we're researching what kind of monitoring we need for each specific unit process in a DPR system. We envision a multiple-barrier concept — for example, not just one treatment for pathogens but three or four barriers. We then monitor each barrier and have procedures to collect and retreat off-spec water.

**tpo: What does all this mean for the people who operate collection systems, wastewater treatment plants and advanced water treatment facilities?**

**Mosher:** State regulators have been very good about working with utilities who are thinking about potable reuse. They often ask: Are the operators trained? Do they have the right certifications? Do they know how to run the advanced treatment? That's part of what is going to ensure success: having great operators who are appropriately trained and experienced.

**tpo: What kinds of additional certifications would operators need?**

**Mosher:** We are researching training approaches for DPR operators and the added certification programs that would be needed. We already have

“State regulators often ask: Are the operators trained? Do they have the right certifications? Do they know how to run the advanced treatment? That's part of what is going to ensure success: having great operators who are appropriately trained and experienced.”

JEFF MOSHER

water and wastewater certifications. To those we could add programs for advanced treatment, or we could develop a certification program for advanced treatment. In other words, if you have a water certification, then you would get a more advanced water certification. That would be up to the states.

**tpo: What about actual training in the site-specific processes?**

**Mosher:** There are organizations developing training programs for these advanced treatment systems, whether that's advanced oxidation or membrane technology. Sending operators to those programs will be a part of it. Then when these operators are being hired or promoted, the utilities will train them on their specific equipment.

**tpo: What about dealing with specific pollutants in wastewater that need to be removed for DPR?**

**Mosher:** A lot of research is going into characterizing trace organic chemicals — chiefly the pharmaceuticals that pass through people and go into the wastewater collection system. We need appropriate analytical methods to detect them, to understand their public health significance, and to what levels we need to treat them. It's the same with pathogens. We need to understand how much treatment is required to produce safe water.

**tpo: What kinds of analytical tools are on the horizon or already here?**

**Mosher:** There are some exciting new monitoring methods coming down. One is next-generation sequencing, which is used to assess microbials in settings from an advanced wastewater treatment process to a drinking water distribution system. This method gives us a list of the full range of microbiologicals present. It's a game changer in terms of our ability to understand the microbial community in a plant or distribution system.

It really comes down to applying these techniques as they become available to see if they can help in assessing chemicals and pathogens. We have current methods, but it is possible that new methods will give us a better understanding. tpo



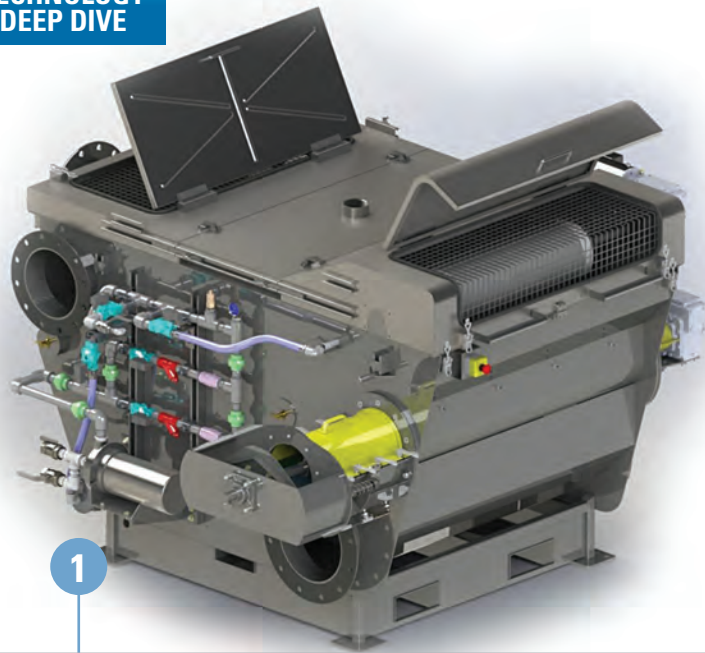

1. The Hydro MicroScreen system is designed to do the same work as a primary clarifier in a smaller footprint.
2. The screen itself looks identical to a window screen except that the mesh size can be varied.
3. The material removal rides on top of the screen; it later falls off by gravity.

# Beyond Settling

HYDRO MICROSREEN TECHNOLOGY COMBINES FINE SCREENING AND PRIMARY TREATMENT, HELPING PLANTS SAVE SPACE AND ENHANCE EFFICIENCY

By Ted J. Rulseh

Primary clarifiers have been basic equipment in wastewater treatment for decades, and they remain effective.

Now, Hydro International offers an alternative form of primary treatment that uses a screening process instead of gravity settling to get the job done. The company says its Hydro MicroScreen system can do the same work as primary clarifiers in a significantly smaller footprint with lower power input and at lower cost of installation.

The technology uses a rotating belt screen to separate out solids, which in smaller plants can include grit and fine screenings as well as the material that comprises primary sludge. The company says the system removes 50 to 60 percent of TSS, along with 20 to 40 percent of BOD and 10 percent of phosphorus by removing their particulate forms.

The process allows engineers and operators to choose from a range of screen mesh sizes and thereby customize the removal rate and optimize the efficiency of downstream processes including nitrification. It is suited for a variety of industrial uses. Matt Bokenkroger, industrial sales manager, talked about the technology in an interview with *Treatment Plant Operator*.

**tpo:** What problems in the marketplace are addressed by this technology?

**Bokenkroger:** First, land values were becoming astronomical so that

plants couldn't obtain land affordably, or the land they acquired was so degraded that it cost significant money to upgrade it. And second, plants were looking to manage solids so as to feed material directly to energy recovery systems. Those include anaerobic digesters, as well as gasification and pyrolysis processes, which are starting to make waves.

**tpo:** So your technology is basically replacing the primary clarifier?

**Bokenkroger:** That's correct. For small plants, under about 4 mgd peak flow, we can combine fine screening, grit removal and advanced primary clarification in one component.

“Because we have a fairly steep but not too steep angle of incline, close to 90 percent of the material falls off by gravity. The rest falls off with low-volume, high-pressure wash water and a secondary scraper.”

MATT BOKENKROGER

**tpo:** In simple terms, how does the screening process work?

**Bokenkroger:** The equipment is typically installed in a stainless steel vessel. The influent level is controlled by the rotational speed of the screen. Heavy solids require a higher screen speed. Lighter solids loading would require a lower screen speed. In either case, the water level stays the same. A level transducer monitors the inlet water cavity, and an algorithm directs the screen to speed up or slow down. In that way we maintain a uniform, thick mat of solids on the screen.



**tpo:** What does this screen look like?

**Bokenkroger:** It looks identical to a window screen, except we can vary the mesh size. If the screen has a 100-micron mesh, then it has 100-micron squares. The screen doesn't stretch or expand. It has greater than 300 pounds per square foot loading capacity, which will never be reached. The material we remove doesn't get trapped inside the screen. It rides on top of it. Because we have a fairly steep but not too steep angle of incline, close to 90 percent of the material falls off by gravity. The rest falls off with low-volume, high-pressure wash water and a secondary scraper.

**tpo:** What happens to the material that is removed?

**Bokenkroger:** Under the screen we have a built-in auger. The auger conveys the material to a discharge point. Along with the auger we can add a dewatering press, if the customer wants it. If there is no press, we expect material at 3 to 5 percent solids, similar to primary clarifier sludge. With a press we expect 20 to 25 percent solids. That material will pass a paint filter test and has been approved to go to landfill. However, being a renewable energy proponent, I would prefer to see the liquid slurry go to digestion or the compressed material to gasification.

**tpo:** How would the footprint of this technology compare to primary clarifiers in different-size treatment plants?

**Bokenkroger:** For large-scale plants, the technology would have as low as 10 percent of the footprint of primary clarifiers and use 20 percent of the power. For a 2 mgd or 3 mgd facility, it's closer to 50 percent of the footprint and 50 percent of the power. We did a theoretical project with an engineering firm for a plant in Oklahoma that had six primary clarifiers. Our MicroScreen would have fit within one-third the space of one of the primary clarifiers.

**tpo:** How can this technology affect downstream processes?

**Bokenkroger:** There are so many variables, but to cite one example, in a biological nutrient removal process, it can reduce sludge wasting and make it easier to maintain the desired food-to-microorganism ratio. Many facilities have found that they can dial down their aeration requirement.

**tpo:** What has been done to ensure that this system is reliable?

**Bokenkroger:** The system was originally designed for use in tanneries, where they can have from 2 to 12 pH, from 0.2 to 3 percent solids loading, and average H<sub>2</sub>S content at 100 to 125 ppm. For municipal plants, our system is several times more robust than what they need. We also designed the components to be maintenance-friendly. For example, on rotational components, we wired the bolts to reduce maintenance. We've also hard-plumbed the grease ports to the top of the unit.

**tpo:** What safety features does this system include?

**Bokenkroger:** Our screen is 100 percent designed to meet OSHA standards for rotational equipment. The access ports where operators can see the screen are guarded with wire mesh. If they lift a lid to get inside, the rotation stops instantly. They

can then perform whatever maintenance or service is needed, and the moment the lid is closed, operation automatically starts again.

**tpo:** How can the equipment be customized to meet a given plant's requirements?

**Bokenkroger:** We offer screen porosities from 70 microns to 5,000 microns. A 70-micron screen has 13 percent open area, while a 1,000-micron screen has 50 percent open area. Most municipal plants just want primary clarification, and we can do that reliably with a 300- to 400-micron screen, unless they also want grit removal, in which case we need a 158-micron screen. Industrial users would often choose a smaller mesh. They want to remove as much material as possible to reduce BOD and TSS surcharges from municipal treatment plants. **tpo**



Whether a marathon-runner or a sprinter, MBR or SBR system, the reliable and proven performance of AERZEN Turbo Blowers exceeds all expectations.



**AERZEN**  
EXPECT PERFORMANCE

AERZEN Turbos impress with up to 80% efficiency. As the core unit in compound systems they generate energy savings of up to 30%. AERZEN Turbo Blowers feature a small footprint and are engineered to integrate seamlessly, with other aeration blower technologies, as the base load blower.

Request a quote from an Aerzen Turbo Blower Specialist:  
(610) 380-0244 [inquiries@aerzenusa.com](mailto:inquiries@aerzenusa.com)

Download The Aerzen Turbo Blower Brochure

[www.aerzenusa.com](http://www.aerzenusa.com)

PD Blowers | Hybrid Blowers | Turbo Blowers



# Target Net Zero

THE WASTEWATER TREATMENT PLANT IN WYOMING'S JACKSON HOLE TAKES PROGRESSIVE STEPS TO FIT IN WITH ITS ENVIRONMENTALLY SENSITIVE SURROUNDINGS

By Doug Day

The first challenge for the Jackson Wastewater Treatment Plant was to reduce energy use by 10 percent. With that achieved, the goal was to treat each gallon 40 percent more efficiently.

The plant exceeded that goal by nearly two times and ahead of schedule. Now Johnny Ziem, wastewater manager, is looking to keep moving the bar and achieve net zero energy at the 5 mgd design/2.2 mgd average lagoon treatment plant in scenic Jackson Hole, Wyoming.

## WATER MIXING

The latest project, installed in summer 2015, is a GridBee mixing system (Medora Corporation) to improve lagoon aeration efficiency. "We were operating 750 hp of aeration/mixing equipment, and we are now running 250 hp," says Ziem. "This helped reduce our carbon footprint by about 1 million kWh. Even with the low power cost of 4.3 cents per kWh, we saved about \$55,000 the first year alone."

The \$561,000 project was funded by the town of Jackson with help from the non-profit Teton County Wastewater Funds and Energy Conservation Works. Lower Valley Energy gave the township a rebate check of \$224,592, covering about 40 percent of the project cost. Including the rebate and first-year savings the payback appears to be six years or less as the system is fine-tuned.

“We’re taught that we should keep dissolved oxygen around 2.25 mg/L. Now we tend to shoot for 1 to 1.5 mg/L. That’s a good example of seeing what changes you can do with the situation that you have.”

**JOHNNY ZIEM**

The mixers are the latest in a list of projects that started when the town council looked at its operations in 2006 and decided to cut overall energy use by 10 percent by 2010, called the 10x10 Initiative. "That was a really good start on this path of really watching our energy, tweaking our use, looking at multiple ways we can save energy that also allows us to avoid some major costs," says Ziem.

## GOING SOLAR

In 2008, the plant installed 144 panels in a 27 kW solar array from Creative Energies in Lander, Wyoming. Two years later, a second phase added 702 panels for an additional 165 kW. "At the point, we had the biggest solar farm in Wyoming," notes Ziem. More solar was to come, but not before the plant took other actions to become more efficient.



Fourteen GridBee mixers (Medora Corporation) pull in water from all corners of the lagoons and redistribute it across the surface to provide mixing.

PHOTOS COURTESY OF THE TOWN OF JACKSON WASTEWATER TREATMENT PLANT

In 2010, old floating mixers that aerated five of the ponds were upgraded to Triton Aire-02 mixers (Aeration Industries) that mix much more efficiently and use less energy. That enabled the plant to meet its original goal of 10 percent energy savings.

The next year, to further reduce electricity use during part of the year, the plant got to work on the two 250 hp blowers for the coarse-bubble diffusion system in the second five lagoons. The plant added a high-speed turbo-blower from HSI (Atlas Copco) for aeration in the five winter months when less air is needed.

Around that time the town board issued a new challenge: The 40x20 Initiative directed the plant was to be 40 percent more efficient by 2020 than in 2006.

## BETTER LAGOONS

In 2013, when Ziem moved from senior wastewater operator to his present position, the group changed the way the lagoons operated. The plant sometimes exceeded its permit maximum pH of 9 in summer and early fall when the lagoons produced substantial amounts of algae.

"Producing algae uses up a lot of alkalinity," says Ziem. "We had the capability to bypass four of the five ponds that were on the diffuser system, and to shut off the air to the last pond and turn that into a polishing pond to try to regain some alkalinity."

Doing so also enabled the two blowers to be shut down at intervals instead of running around the clock. That reduced blower electricity usage from 4.3 million kWh to 2.8 million kWh per year and eliminated pH violations. The



mixers were also shut off at times in the primary ponds, allowing the operators to lower dissolved oxygen to the spot where the plant could meet effluent standards with the least energy.

“We’re taught that we should keep dissolved oxygen around 2.25 mg/L,” says Ziem. “Now we tend to shoot for 1 to 1.5 mg/L. That’s a good example of seeing what changes you can do with the situation that you have.”

## EFFICIENT HEATING

In 2014, the plant team replaced its old and inefficient propane heaters with 93 percent efficient propane heaters (Modine Manufacturing). “We didn’t just swap out all of them,” Ziem says. “We looked holistically at our facilities. One was in an office that wasn’t occupied all the time, so we put in an electric radiant heater and programmable thermostat. Some others we just turned off.”

One such location was a storage garage where heaters kept a waterline from freezing. The water wasn’t used in winter, so the line was closed and drained, and the heaters turned off. Thermostats were reset from 68 to 50 degrees in the UV disinfection building and a pump building, which were unoccupied. These measures cut propane use from 11,000 gallons to 5,500 gallons per year.

A year later, the plant added 246 more solar panels (69 kW) from Creative Energies to power a pumping facility. That brought solar capacity to 261 kW. “With all the solar we’ve added, of our three main facilities, two are net zero; we produce more electricity than those buildings use.”

LEFT: A blower from HSI (Atlas Copco) with an integrated variable frequency drive and motor offers high efficiency, lower sound, and virtually no maintenance. BELOW: Replacing old suspended heaters with units that have 93 percent thermal efficiency (Modine Manufacturing) and by lowering building temperatures, the Jackson plant was able to cut propane use in half.



The plant also revisited the Triton blowers added five years before. Their SCADA-connected dissolved oxygen sensors in lagoons had to be cleaned every two days from a rowboat. “We ended up not using them, and I felt we were missing a good opportunity to understand what happens with DO throughout the day,” Ziem says.

The sensors were moved to the diversion structures between ponds, where less algae grows and the sensors can be accessed on foot. The SCADA system was updated to track DO every minute in real time. “We can now really

# SAF-T-FLO

## CHEMICAL INJECTION



SAF-T-FLO retractable injection quills are designed to provide a maintenance friendly way of maintaining injection feeds prone to scale and clogging.

Rarely are any two injection points the same. Our wide range of sizes, materials, and unique features allows each quill to be configured for the intended application. No compromises, just the right tool for the job.

### Key Features

- 1/2" to 3" Connection Sizes
- Restraint ratings of both 150psi and 250psi.
- Integrated check valves on select sizes.
- Does not require the main to be depressurized for insertion/removal.
- SAF-T-Seal Elastomeric Tip for excessive scale prone feeds.



**Learn More**  
call: 800-957-2383  
visit: [www.saffflo.com](http://www.saffflo.com)  
view: [youtube.com/saffflo](https://youtube.com/saffflo)

FREE INFO – SEE ADVERTISER INDEX

understand what happens with dissolved oxygen,” Ziem says. “It really sky-rockets in the afternoon.”

## TAKING CHANCES

Ziem understands that lagoon systems with long detention times are forgiving, so he’s not afraid to experiment. “It’s kind of trial and error,” he says. “I can look at a graph and see what we did and what happened. You can always turn stuff back on and not get yourself in a hole.”

And the 40x20 Initiative? That was met in 2014. As of last year, the 36-year-old plant was treating each gallon 70 percent more efficiently than in 2006. Electricity use has been reduced by 4.5 million kWh per year. “We’re between \$50,000 and \$70,000 a year that we’re not spending on electricity and propane,” Ziem says.

His new objective is a completely net-zero plant, getting all energy from on-site sources. There’s a long way to go, but he will keep looking. **tpo**



# Going With the Flow

HANDS-ON ACTIVITIES TEACH MAINE MIDDLE SCHOOL STUDENTS ABOUT THE WATER CYCLE, RUNOFF PREVENTION AND WATERSHED PRESERVATION

By Craig Mandli



PHOTOS COURTESY OF THE PORTLAND WATER DISTRICT

Students in Portland get a lesson on watersheds using epoxy models that mimic how water moves in the environment.

They can be a drop of saltwater in the Atlantic Ocean. Or a drop of clean water fresh from a well. Or even a drop of wastewater making its way through a sewer.

Middle school students in Maine learn about the water cycle by pretending to be water droplets as part of the Portland Water District's WaterWays, a 20-year-old program that teaches kids about preserving water resources.

The WaterWays program brings hands-on learning in the sciences to about 1,000 students across southern Maine each year. Recent changes keep things fresh and help it fit with national science education standards. "WaterWays lets them know what they can personally do to help improve our water resources," says Sarah Plummer, environmental education coordinator with the district.

In previous years, an environmental educator attended one class each month during the school year. Now, with more funding available, the district has a full-time educator and a more concentrated program that helps students engage and retain what they learn. Educators visit the classrooms once a week over four weeks, delivering hands-on and sensory lessons to involve kids in science, especially as it applies to water.

## HANDS-ON APPROACH

Schools can choose different themes to fit with their science curricula. For instance, one lesson introduced six landscaping techniques to prevent erosion and divert runoff from water bodies. Simple ideas like planting trees and shrubs along the waterline and placing rain barrels under rain gutters are the same concepts water district scientists use to solve real-world problems.

After the lesson, groups of students were given two-dimensional landscape models of a backyard and a list of three water management problems to solve. Using their lessons, they created a model of their solutions using a diagram of the home and pieces of felt to represent management techniques.

"I've always felt that students, especially those in middle school, understand more when they learn through their senses," Plummer says. "It's great see-

“I've always felt that students, especially those in middle school, understand more when they learn through their senses. It's great seeing that light go on as they grasp what can be some pretty complicated concepts.”

**SARAH PLUMMER**





Students in Gorham get an up-close look at the impact of pollution. The lesson is part of the Portland Water District WaterWays program.



Environmental educator Jason Duff teaches students about watershed buffer areas.



Hands-on activities engage students in devising solutions to real-world water problems.

ing that light go on as they grasp what can be some pretty complicated concepts.”

In the water cycle lesson, students roll dice to select where in the water cycle their droplets start and then collect colored beads to track their journey. “That lesson is neat because the students don’t realize how many parts of the water cycle one droplet can be a part of,” says Plummer. “It also drives home the idea that pollution to one portion of the water cycle can have a negative impact on many parts.”

### IN THE FIELD

Other lessons include treatment plant tours and field trips to learn about aquatic habitats. In another lesson, kids pour water on epoxy watershed models that mimic how water moves in the environment. Teachers tell Plummer these lessons are favorites. “The teachers are very on-board with what we’re doing,” she says. “In fact, we have trouble meeting the need with the educator team we have in place.”

Plummer says the goal is to see students use the conservation techniques in their own lives and start conversations with their parents about how they can work as a family to protect the watershed.

“We do outreach aimed at adults and homeowners as well, but sometimes I feel that the point can get driven home if we can get the kids passionate about it,” she says. “We also provide follow-up materials for teachers to continue the lessons as part of the in-class curriculum. We know our time with these students is limited, so it’s about making the biggest impact we can.” **tpo**

### What’s Your Story?

**TPO welcomes news about your public education and community outreach efforts for future articles in the Hearts and Minds column. Send your ideas to [editor@tpomag.com](mailto:editor@tpomag.com) or call 877/953-3301.**



# tpo™ 2017

## ANNUAL COMPANY DIRECTORY of Municipal Treatment Plant Industry Manufacturers & Suppliers

■ Advertisers in the magazine are listed in blue and bolded.



800-257-7222 or 715-546-3346

**WWW.TPOMAG.COM**

## ALPHABETICAL LISTINGS

### A

#### **Activated Carbon Services - PACS**

409 Meade Dr.  
Coraopolis, PA 15108  
800-367-2587 • 724-457-6576  
henry@pacslabs.com  
www.pacslabs.com

#### **AdEdge Water Technologies, LLC**

2055 Boggs Rd.  
Duluth, GA 30096  
866-823-3343 • 678-835-0052 • Fax: 678-835-0057  
sales@adedgetechnologies.com  
www.adedgetech.com

**Ad on page 25**

#### **Aeration Industries International**

4100 Peavey Rd.  
Chaska, MN 55318  
800-328-8287 • 952-448-6789 • Fax: 952-448-7293  
aii@aireo2.com  
www.aireo2.com

#### **Aerzen USA**

108 Independence Way  
Coatesville, PA 19320  
610-380-0244  
aerzen@aerzenusa.com  
www.aerzen.com/en-us/

**Ad on page 45**

#### **AGC Chemicals Americas, Inc.**

55 E Uwchlan Ave., Ste. 201  
Exton, PA 19341  
800-424-7833 • 610-423-4300 • Fax: 610-423-4301  
www.agchem.com

#### **Agru America, Inc.**

500 Garrison Rd.  
Georgetown, SC 29440  
800-373-2478 • 843-546-0600 • Fax: 843-527-2738  
salesmkg@agruamerica.com  
www.agruamerica.com



#### **Airmaster Aerator LLC**

PO Box 546  
DeRidder, LA 70634  
888-813-3680 • 337-463-6567 • Fax: 337-463-9119  
deanc@airmasteraerator.com  
www.airmasteraerator.com

**Ad on page 4**

#### **Alfa Laval Inc.**

5400 International Trade Dr.  
Richmond, VA 23231  
866-253-2528  
customerservice.usa@alfalaval.com  
www.alfalaval.us

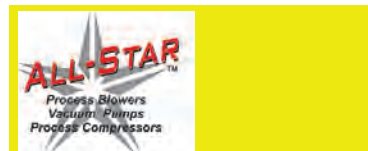

#### **All-Star Products**

2095 Exeter Rd., Ste. 80-324  
Memphis, TN 38138  
800-431-8258 • 901-755-9613  
edwardb@all-star-usa.com  
www.all-star-usa.com

**Ad on page 21**



#### **AllChem Performance Products**

6010 NW First Pl.  
Gainesville, FL 32607  
352-333-7327 • Fax: 866-343-1216  
horizon@allchem.com  
www.horizonwater.com

#### **AllMax Software, Inc.**

911 S Main St.  
Kenton, OH 43326  
800-670-1867 • 419-673-8863 • Fax: 419-673-8864  
sales@allmaxsoftware.com  
www.allmaxsoftware.com

**Ad on page 31**

#### **American Pleasure Products, Inc.**

2823 E Industrial Dr.  
Rose City, MI 48654  
989-685-2697 • Fax: 989-685-8484  
info@aquacycleusa.com  
www.aquacycleusa.com

**Ad on page 77**

#### **American Water Works Association**

6666 W Quincy Ave.  
Denver, CO 80235  
800-926-7337 • Fax: 303-347-0804  
www.awwa.org

**Ad on page 65**

#### **AMETEK Drexelbrook**

205 Keith Valley Rd.  
Horsham, PA 19044  
215-674-1234 • Fax: 215-674-2731  
drexelbrook.info@ametek.com  
www.drexelbrook.com

#### **Amiad USA**

120-J Talbert Rd.  
Mooresville, NC 28117  
704-662-3133 • Fax: 704-662-3155  
infousa@amiad.com  
www.amiadusa.com



#### **AmTech Tank Lining & Repair**

75-4 Main St., Ste. 300  
Plymouth, NH 03264  
888-839-0373 • Fax: 603-947-9500  
info@amtechtanklining.com  
www.amtechtanklining.com

**Ad on page 91**

#### **AMWELL, A Div. of McNish Corp.**

600 N Commons Dr., Ste. 116  
Aurora, IL 60504  
630-898-6900 • Fax: 630-898-1647  
phaizman@amwell-inc.com  
www.amwell-inc.com

#### **Analytical Technology, Inc.**

6 Iron Bridge Dr.  
Collegeville, PA 19426  
800-959-0299 • 610-917-0991 • Fax: 610-917-0992  
sales@analyticaltechnology.com  
www.analyticaltechnology.com

**Ad on page 118**



#### **Anue Water Technologies, Inc.**

1923 Avenida Plaza Real  
Oceanside, CA 92056  
760-727-2683  
info@anuewater.com  
www.anuewater.com

#### **Aqseptence Group Inc.**

1950 Old Hwy 8 NW  
New Brighton, MN 55112  
800-833-9473 • 651-636-3900 • Fax: 651-638-3171  
matthew.bentley@aqseptence.com  
www.johnsonscreens.com



#### **Aqua Operations, Inc.**

PO Box 9956  
Bakersfield, CA 93389  
888-746-6535 • 661-331-1181 • Fax: 661-833-1861  
childerbrand@aquaooperations.com  
www.aquaooperations.com

#### **Aqua-Aerobic Systems, Inc.**

6306 N Alpine Rd.  
Loves Park, IL 61111  
800-940-5008 • 815-654-2501 • Fax: 815-654-2508  
solutions@aquaaerobic.com  
www.aquaaerobic.com

**Ad on page 11**

#### **Aqualitec Corp.**

3415 S Sepulveda Blvd., Ste. 1100  
Los Angeles, CA 90034  
855-650-2214  
info@aqualitec.com  
www.aqualitec.com



**AQUATURBO SYSTEMS, Inc.**  
1754 Ford Ave.  
Springdale, AR 72764  
479-927-1300 • Fax: 479-927-0700  
ats@aquaturbo.com  
www.aquaturbousa.com

**ASA Analytics**  
2325 Parklawn Dr., Ste. I  
Waukesha, WI 53186  
262-717-9500 • Fax: 262-717-9530  
info@chemscan.com  
www.asaanalytics.com

**Asahi/America, Inc.**  
655 Andover St.  
Lawrence, MA 01843  
800-343-3618 • 781-321-5409 • Fax: 800-787-6861  
asahi@asahi-america.com  
www.asahi-america.com

## B

### bcv ENVIRONMENTAL

**BCR Environmental Corporation**  
6621 Southpoint Dr. N, Ste. 200  
Jacksonville, FL 32216  
904-819-9170 • Fax: 904-998-3828  
marketing@bcenv.com  
www.bcenv.com

**BDP Industries**  
354 State Rte. 29  
Greenwich, NY 12834  
518-695-6851 • Fax: 518-695-5417  
dan@bdpindustries.com  
www.bdpindustries.com

**BinMaster Level Controls**  
7201 N 98th St.  
Lincoln, NE 68507  
800-278-4241 • 402-434-9102 • Fax: 402-434-9133  
info@binmaster.com  
www.binmaster.com

### BIO MICROBICS

BETTER WATER. BETTER WORLD.

**Bio-Microbics, Inc.**  
8450 Cole Pkwy.  
Shawnee, KS 66227  
800-753-3278 • 913-422-0707 • Fax: 913-422-0808  
sales@biomicrobics.com  
www.biomicrobics.com

**BioAir Solutions LLC**  
110 Kresson-Gibbsboro Rd., Ste. 303  
Voorhees, NJ 08043  
856-258-6969 • Fax: 856-258-6975  
cwest@bioairsolutions.com  
www.bioairsolutions.com

**Bionetix International**  
21040 Rue Daoust  
Ste-Anne-de-Belleuve, QC H9X 4C7  
Canada  
514-457-2914 • Fax: 514-457-3589  
info@bionetix.ca  
www.bionetix-international.com

### Blue-White Industries, Ltd.

**Blue-White Industries**  
5300 Business Dr.  
Huntington Beach, CA 92649  
714-893-8529 • Fax: 714-894-9492  
sales@blue-white.com  
www.blue-white.com

Ad on page 2

### BÖRGER

**Boerger, LLC**  
2860 Water Tower Pl.  
Chanhassen, MN 55317  
612-435-7300 • Fax: 612-435-7301  
america@boerger.com  
www.boerger.com

Ad on page 55

### BOHN BIOFILTER!

Odor and Air Emissions Control

**BOHN BIOFILTER**  
PO Box 44235  
Tucson, AZ 85733  
520-624-4644  
info@bohnbiofilter.com  
www.bohnbiofilter.com



**Bradley Innovation Group**  
6919 Brookville Rd.  
Indianapolis, IN 46239  
317-726-6615  
sales@big-h2o.com  
www.big-h2o.com

**Bright Technologies,  
Division of Sebright Products, Inc.**  
127 N Water St.  
Hopkins, MI 49328  
800-253-0532 • 269-793-7183 • Fax: 269-793-4022  
julie@brightbeltpress.com  
www.brightbeltpress.com

Ad on page 83

**Brown Bear Corporation**  
2248 Avenue of Industries  
Corning, IA 50841  
641-322-4220 • Fax: 641-322-3527  
sales@brownbearcorp.com  
www.brownbearcorp.com

**Busch Vacuum Pumps and Systems**  
516 Viking Dr.  
Virginia Beach, VA 23452  
800-872-7867 • 757-463-7800 • Fax: 757-463-7407  
marketing@buschusa.com  
www.buschusa.com

**Byo-Gon, Inc.**  
1190 Clements Ferry Rd., Ste. D  
Charleston, SC 29492  
888-796-4661 • 843-822-3415 • Fax: 843-606-6318  
info@byogon.com  
www.byogon.com

Ad on page 117

## C

**Cam Spray**  
520 Brooks Rd.  
Iowa Falls, IA 50126  
800-648-5011 • 641-648-5011 • Fax: 641-648-5013  
sales@camspray.com  
www.camspray.com

Ad on page 87

**CEI - Carbon Enterprises Inc.**  
28205 Scippo Creek Rd.  
Circleville, OH 43113  
800-344-5770 • Fax: 888-204-9656  
info@ceicompanies.com  
www.ceifiltration.com

**CEM Corporation**  
3100 Smith Farm Rd.  
Matthews, NC 28104  
800-726-3331 • Fax: 704-821-7015  
info@cem.com  
www.cem.com

Ad on page 67

**Central Life Sciences**  
1501 E Woodfield Rd., Ste. 200W  
Schaumburg, IL 60173  
800-367-0659  
conrel@central.com  
www.strikeproducts.com

Ad on page 17

### centrisys

CENTRIFUGE SYSTEMS

**Centrisys Corporation**  
9586 58th Pl.  
Kenosha, WI 53144  
262-654-6006 • Fax: 262-764-8705  
info@centrisys.us  
www.centrisys.com

Ad on page 81

### CharterMachine Company

**Charter Machine Company**  
55 Wester Ave.  
Metuchen, NJ 08840  
732-548-4400  
walterk@chartermachine.com  
www.chartermachine.com

**CHEMetrics, Inc.**  
4295 Catlett Rd.  
Midland, VA 22728  
800-356-3072 • 540-788-9026 • Fax: 540-788-4856  
sales@chemetrics.com  
www.chemetrics.com

**Chromalox**  
103 Gamma Dr.  
Pittsburgh, PA 15238  
800-443-2640 • 412-967-3800 • Fax: 412-967-5148  
sales@chromalox.com  
www.chromalox.com

**Cla-Val**  
1701 Placentia Ave.  
Costa Mesa, CA 92627  
800-942-6326 • 949-722-4800 • Fax: 949-574-5703  
info@cla-val.com  
www.cla-val.com

**CleanTek Water Solutions**  
7984 University Ave.  
Fridley, MN 55432  
866-929-7773  
info@cleantekwater.com  
www.cleantekwater.com

**ClearSpan Fabric Structures**  
1395 John Fitch Blvd.  
South Windsor, CT 06074  
866-643-1010  
trussinquiry@clearspan.com  
www.clearspan.com

Ad on page 77



**CNP-Technology Water and Biosolids Corp.**  
9535 58th Pl.  
Kenosha, WI 53144  
262-764-3651 • Fax: 262-764-8705  
info@cnptec.com  
www.cnptec.com

Ad on page 85

**Crane Pumps & Systems**  
420 Third St.  
Piqua, OH 45356  
937-778-8947 • Fax: 937-773-7157  
cranepumps@cranepumps.com  
www.cranepumps.com



**CST Industries, Inc.**  
904 E. 104th Ave. Ste. 900  
Kansas City, MO 64131  
913-621-3700  
sales@cstindustries.com  
www.cstindustries.com

## D

**Data Flow Systems, Inc.**  
605 N John Rodes Blvd.  
Melbourne, FL 32934  
321-259-5009 • Fax: 321-259-4006  
info@dataflowsys.com  
www.dataflowsys.com

**Deep Trekker Inc.**  
830 Trillium Drive  
Kitchener, ON N2R 1K4  
Canada  
519-342-3177  
sales@deeptrekker.com  
www.deeptrekker.com

Ad on page 93



**Delta M Corporation**  
1003 Larsen Dr.  
Oak Ridge, TN 37830  
800-922-0083 • 865-483-1569 • Fax: 865-483-1142  
sales@deltamcorp.com  
www.deltamcorp.com



**Dragon Products, Ltd.**  
1655 Louisiana St.  
Beaumont, TX 77701  
800-231-8198  
sales@modernusa.com  
www.dragonproductsltd.com

**DRYCAKE**  
208-2255 Cypress St.  
Vancouver, BC V6J 3M6  
Canada  
877-379-2253 • 604-535-2238  
sales@drycake.com  
www.drycake.com

**Duperon Corporation**  
1200 Leon Scott Ct.  
Saginaw, MI 48601  
800-383-8479 • 989-754-8800 • Fax: 989-754-2175  
bbauer@duperon.com  
www.duperon.com

**Duramax Cast Stainless Steel Chain & Equipment Products**  
PO Box 786  
Pewaukee, WI 53072-0786  
800-691-0998 • 262-691-0998 • Fax: 262-691-0992  
www.duramaxchain.com

**E**



**Eagle Microsystems, Inc.**  
366 Circle of Progress Dr.  
Pottstown, PA 19464  
800-780-8636 • 610-323-2250 • Fax: 610-323-0114  
info@eaglemicrosystems.com  
www.eaglemicrosystems.com



**EBARA**  
**EBARA Fluid Handling**  
1651 Cedar Line Dr.  
Rock Hill, SC 29730  
803-327-5005 • Fax: 803-327-5097  
sales@pumpsebara.com  
www.pumpsebara.com

**Electrolytic Technologies LLC**  
19597 NE 10th Ave.  
North Miami Beach, FL 33179  
305-655-2755 • Fax: 305-655-2669  
info@electrolytictech.com  
www.electrolytictech.com  
**Ad on page 116**

**ElectroSwitch Corporation**  
180 King Ave.  
Weymouth, MA 02188  
781-335-5200  
info@electroswitch.com  
www.electroswitch.com

**Emerson / Rosemount**  
6021 Innovation Blvd.  
Shakopee, MN 55379  
800-854-8257 • 952-906-8888  
liquid.csc@emerson.com  
www.rosemount.com



**Emerson Automation Solutions**  
200 Beta Dr.  
Pittsburgh, PA 15238  
800-445-9723 • 412-963-4000  
powerwater@emerson.com  
www.emerson.com/water

**Endress+Hauser**

**Endress+Hauser**  
2350 Endress Pl.  
Greenwood, IN 46143  
888-363-7377 • Fax: 317-535-8498  
info@us.endress.com  
www.us.endress.com



**ENMET**  
680 Fairfield Ct.  
Ann Arbor, MI 48108  
800-521-2978 • 734-761-1270 • Fax: 734-761-3220  
info@enmet.com  
www.enmet.com



**Enterprise Specialty Products**  
400 Catherine St.  
Laurens, SC 29360  
864-984-7700 • Fax: 864-984-2241  
www.enterprisesp.com



**Enviro-Care Company**  
1570 St. Paul Ave.  
Gurnee, IL 60031  
815-636-8306 • Fax: 847-672-7968  
ecsales@enviro-care.com  
www.enviro-care.com  
**Ad on page 59**

**Environetics, Inc.**  
1201 Commerce St.  
Lockport, IL 60441  
815-838-8331 • Fax: 815-838-8336  
info@environeticsinc.com  
www.environeticsinc.com

**Environmental Coatings LLC**  
4702 E Virginia St.  
Mesa, AZ 85215  
480-984-7608  
info@sewershield.com  
www.sewershield.com



**EnviroSuite**  
533 Airport Rd., Ste. 330  
Burlingame, CA 94010  
424-335-1331  
inquiries@envirosuite.com  
www.envirosuite.com

**Eurus Blower, Inc.**  
PO Box 4588  
Wheaton, IL 60189  
630-221-8282 • Fax: 630-221-1002  
tomh@eurusblower.com  
www.eurusblower.com  
**Ad on page 95**

**Evoqua Water Technologies LLC**  
181 Thorn Hill Rd.  
Warrendale, PA 15086  
800-466-7873 • 724-772-0044  
municipalmarketing@evoqua.com  
www.evoqua.com

**F**



**F & V Operations and Resource Management**  
2690 Lucerne Dr. SE  
Grand Rapids, MI 49546  
888-773-8806 • 616-588-2900 • Fax: 616-977-1005  
bselover@fv-operations.com  
www.fv-operations.com



**FCI - Fluid Components International**  
1755 La Costa Meadows Dr.  
San Marcos, CA 92078  
800-854-1993 • 760-744-6950 • Fax: 760-736-6250  
eflow@fluidcomponents.com  
www.fluidcomponents.com

**Fibergrate Composite Structures**  
5151 Beltline Rd., Ste. 1212  
Dallas, TX 75254  
800-527-4043 • 972-250-1633 • Fax: 972-250-1530  
info@fibergrate.com  
www.fibergrate.com

**FKC Co., Ltd.**  
2708 W 18th St.  
Port Angeles, WA 98363  
360-452-9472 • Fax: 360-452-6880  
mail@fkcscrewpress.com  
www.fkcscrewpress.com

**Flomatic Valves**  
15 Pruyans Island Dr.  
Glens Falls, NY 12801  
800-833-2040 • 518-761-9797 • Fax: 518-761-9798  
flomatic@flomatic.com  
www.flomatic.com

**Flottweg Separation Technology, Inc.**  
10700 Toebben Dr.  
Independence, KY 41051  
859-448-2331 • Fax: 859-448-2333  
sales@flottweg.net  
www.flottweg.com

**Flowrox, Inc.**  
808 Barkwood Ct., Ste. N  
Linthicum, MD 21090  
410-636-2250 • Fax: 410-636-9062  
sales-us@flowrox.com  
www.flowrox.com

**Fluidyne Corporation**  
5436 Nordic Dr., Ste. D  
Cedar Falls, IA 50613  
319-266-9967 • Fax: 319-277-6034  
fluidyne@fluidynecorp.com  
www.fluidynecorp.com



**Force Flow**  
2430 Stanwell Dr.  
Concord, CA 94520  
800-893-6723 • 925-686-6700 • Fax: 925-686-6713  
info@forceflow.com  
www.forceflow.com  
**Ad on page 89**

**Ford Hall Company, Inc.**  
PO Box 2110  
Richmond, KY 40476  
859-624-1077 • Fax: 859-624-3320  
sperry@fordhall.com  
www.weir-wolf.com  
**Ad on page 79**

**Fortiline Waterworks**  
7025 Northwoods Dr. NW  
Concord, NC 28027  
844-792-7473 • 704-788-9800  
www.fortiline.com



**Fournier Industries, Inc.**  
3787 Frontenac Blvd. W  
Theftford Mines, QC G6H 2B5  
Canada  
941-757-7201 • 418-423-4241 • Fax: 418-423-7366  
f.caouette@fournierindustries.com  
www.rotary-press.com  
**Ad on page 91**

**G**

**Gardner Denver Inc.**  
1800 Gardner Expy.  
Quincy, IL 62305  
866-428-4890 • Fax: 217-221-8780  
www.gardnerdenver.com/gdproducts  
**Ad on page 61**

**Garland Manufacturing Company**  
55 Industrial Park Rd.  
Saco, ME 04072  
800-727-1900 • 207-283-3693 • Fax: 207-283-4834  
wastewater@garlandmfg.com  
www.garlandmfg.com/plastics/wastewater.html  
**Ad on page 89**





**GEA Group**  
100 Fairway Ct.  
Northvale, NJ 07647  
800-722-6622 • 201-767-3900 • Fax: 201-767-3901  
info.wsus@gea.com  
www.gea.com

**Geomembrane Technologies Inc.**  
370 Wilsey Rd.  
Fredericton, NB E3B 6E9  
Canada  
855-484-4630 • 506-452-7304 • Fax: 506-452-6625  
covers@gticovers.com  
www.gticovers.com

**GillTrading.com, Inc./WeirWasher, ACS**  
6107 SW Murray Blvd., Ste. 321  
Beaverton, OR 97008  
866-447-2496 • 503-628-0197 • Fax: 503-646-9293  
brentgill@gilltrading.com  
www.gilltrading.com



**Glasdon, Inc.**  
5200D Anthony Rd.  
Sandston, VA 23150  
855-874-5273 • 804-726-3777 • Fax: 804-726-3778  
inquiries@glasdon.com  
www.us.glasdon.com

**GORE® Cover**  
105 Views Way  
Elkton, MD 21921  
410-506-5041  
bfuchs@wlgore.com  
www.gorecover.com



**Gorman-Rupp Company**  
600 S Airport Rd.  
Mansfield, OH 44903  
419-755-1011 • Fax: 419-755-1251  
grsales@gormanrupp.com  
www.GRPumps.com

**Graver Technologies**  
200 Lake Dr.  
Glasgow, DE 19702  
302-731-1700 • Fax: 302-369-0938  
info@gravertech.com  
www.gravertech.com

**Greener Planet Systems**  
7260 Highway F70 West  
Monroe, IA 50170  
888-669-1787 • 517-719-2580  
brianm@greenerplanetsystems.com  
www.greenerplanetsystems.com



**Gryphon Environmental**  
2920 Fairview Dr.  
Owensboro, KY 42303  
270-485-2680  
info@2gryphon.com  
www.2gryphon.com

**H**

**Hach**  
5600 Lindbergh Dr.  
Loveland, CO 80538  
800-227-4224 • 970-669-3050  
orders@hach.com  
www.hach.com

Ad on page 5



**Your Partner in Safety**  
**Halogen Valve Systems, Inc.**  
17961 Sky Park Cir., Ste. A  
Irvine, CA 92614  
949-261-5030 • Fax: 949-261-5033  
info@halogenvlve.com  
www.halogenvlve.com

**Harwil Corp.**  
541 Kinetic Dr.  
Oxnard, CA 93030  
805-988-6800 • Fax: 805-988-6804  
sales@harwil.com  
www.harwil.com

**Hawk Measurement**  
96 Glenn St., Ste. 100B  
Lawrence, MA 01843  
888-429-5538 • 978-304-3000 • Fax: 978-304-1462  
info@hawkmeasure.com  
www.hawkmeasure.com

**Hawkins Water Treatment Group**  
2381 Rosegate  
Roseville, MN 55113  
800-328-5460 • 612-331-6910 • Fax: 612-331-5304  
laura.eilek@hawkinsinc.com  
www.hawkinsinc.com

**Hayward Flow Control**  
One Hayward Industrial Dr.  
Clemmons, NC 27012  
888-429-4635 • Fax: 888-778-8410  
hfcsales@hayward.com  
www.haywardflowcontrol.com

Ad on page 15

**Headworks International, Inc.**  
11000 Brittonmoore Park Dr.  
Houston, TX 77041  
713-647-6667 • Fax: 713-647-0999  
hw@headworksintl.com  
www.headworksintl.com

**FREE TRIAL PUMPS**



**ACE<sup>17</sup>**  
American Water Works Association  
ANNUAL CONFERENCE & EXPOSITION  
Booth 3310

**HEAVY DUTY SLUDGE PUMPS**

- Pumps with no rotors, stators or lobes to replace, providing superior abrasive handling
- Just one wearing part - the hose
- Flows to 300 GPM
- Suction lift to 30 feet, dry running and reversible
- Eliminate ancillary equipment
- Ideal for centrifuge and belt press feed
- No mechanical seals or packing to leak

**Bredel**  
Hose Pumps

wmftg.com  
800-282-8823

**WATSON MARLOW**  
Fluid Technology Group

**HEMCO Corporation**

711 S Powell Rd.  
Independence, MO 64056  
800-779-4362 • 816-796-2900 • Fax: 816-796-3333  
info@hemcocorp.com  
www.hemcocorp.com

**Ad on page 117**

**Hidrostal Pumps**

2225 White Oak Cir., Ste. 101  
Aurora, IL 60502  
630-948-3355 • Fax: 630-948-3353  
info@hidrostalpumps.com  
www.hidrostalpumps.com

**Howden Roots**

900 W Mount St.  
Connersville, IN 47331  
800-557-6687 • 765-827-9200 • Fax: 765-827-9317  
connersville.customer@howden.com  
www.howdenroots.com

**HRS HEAT EXCHANGERS**

840 Kennesaw Ave., NW B-1  
Marietta, GA 30060  
770-726-3540  
info@hrs-heatexchangers.com  
www.hrs-heatexchangers.com



**Huber Technology, Inc.**

9735 NorthCross Center Ct., Ste. A  
Huntersville, NC 28078  
704-949-1010 • Fax: 704-949-1020  
marketing@hhusa.net  
www.huberforum.net

**Ad on page 9**

**Hydra-Tech Pumps**

167 Stock St.  
Nesquehoning, PA 18240  
570-645-3779 • Fax: 570-645-4061  
htpump@hydra-tech.com  
www.hydra-tech.com



**Hydrite Chemical Co.**

300 N Patrick Blvd.  
Brookfield, WI 53045  
262-792-1450  
marketing@hydrite.com  
www.hydrite.com



**Hydro International**

2925 NW Alolek Dr., Ste. 140  
Hillsboro, OR 97124  
866-615-8130 • 503-615-8130 • Fax: 503-615-2906  
questions@hydro-int.com  
www.hydro-int.com

**Ad on page 63**

**Hydromantis Environmental Software Solutions, Inc.**

406 King St. West  
Hamilton, ON L8P 1B5  
Canada  
905-522-0012 • Fax: 905-522-0031  
info@hydromantis.com  
www.hydromantis.com

**In-Pipe Technology**

725 N Central Ave.  
Wood Dale, IL 60191  
888-325-5033 • 630-509-2488 • Fax: 630-509-2490  
jwilliams@in-pipe.com  
www.in-pipe.com



**Indusco Environmental Services, Inc.**

PO Box 8093  
Spanish Fort, AL 36577  
251-621-2338  
sales@induscoenviro.com  
www.induscoenviro.com

**Industrial Scientific**

1 Life Way  
Pittsburgh, PA 15205  
412-788-4353 • Fax: 412-788-8353  
info@indsci.com  
www.indsci.com

**International Products Corporation**

201 Connecticut Dr.  
Burlington, NJ 08016  
609-386-8770 • Fax: 609-386-8438  
mkt@ipcol.com  
www.ipcol.com



**IWAKI America**

5 Boynton Rd.  
Holliston, MA 01746  
508-429-1440  
info@iwakiamerica.com  
www.iwakiamerica.com

**J**

**JDV Equipment Corporation**

1 Princeton Ave.  
Dover, NJ 07801  
973-366-6556 • Fax: 973-366-3193  
sales@jdvequipment.com  
www.jdvequipment.com

**Ad on page 83**

**JPCI Services**

4702 E Virginia St.  
Mesa, AZ 85215  
480-986-1212  
info@jpciservices.com  
www.jpciservices.com

**K**

**KCH Engineered Systems**

144 Industrial Dr.  
Forest City, NC 28043  
828-245-9836  
khankinson@kchservices.com  
www.kchservices.com

**Kee Safety, Inc.**

100 Stradman St.  
Buffalo, NY 14206  
800-851-5181 • 716-896-4949 • Fax: 716-896-5696  
info@keesafety.com  
www.keesafety.com

**Keller America Inc.**

351 Bell King Rd.  
Newport News, VA 23606  
877-253-5537 • 757-596-6680 • Fax: 757-596-6659  
sales@kelleramerica.com  
www.kelleramerica.com

**Ad on page 7**

**Kifco, Inc.**

700 S Schrader Ave.  
Havana, IL 62644  
800-452-7017 • 309-543-4425 • Fax: 309-543-4945  
sales@kifco.com  
www.kifco.com

**Ad on page 116**



**Komline-Sanderson**

12 Holland Ave.  
Peapack, NJ 07977  
800-225-5457 • 908-234-1000 • Fax: 908-234-9487  
info@komline.com  
www.komline.com

**Ad on page 69**

**KSB, Inc.**

4415 Sarellan Rd.  
Henrico, VA 23231  
800-945-7867 • 804-222-1818 • Fax: 804-226-6961  
sales@ksbusa.com  
www.ksbusa.com

**Kuhn North America, Inc.**

PO Box 167  
Brodhead, WI 53520  
608-897-2131 • Fax: 608-897-2561  
chris.searles@kuhn.com  
www.kuhnnorthamerica.com

**Ad on page 8**

**L**



Cleaner Water for a Brighter Future®

**Lakeside Equipment Corporation**

1022 E Devon Ave.  
Bartlett, IL 60103  
630-837-5640 • Fax: 630-837-5647  
sales@lakeside-equipment.com  
www.lakeside-equipment.com

**Ad on page 3**

**LaMotte Company**

802 Washington Ave.  
Chestertown, MD 21620  
800-344-3100 • 410-778-3100 • Fax: 410-778-6394  
mkt@lamotte.com  
www.lamotte.com

**LANXESS / International Dioxide, Inc.**

40 Whitecap Dr.  
North Kingstown, RI 02852  
401-295-8800 • Fax: 401-295-7108  
adox@lanxess.com  
www.lanxess.com

**Lutz-JESCO America Corp.**

55 Bernar Park  
Rochester, NY 14624  
800-554-2762 • 585-426-0990 • Fax: 585-426-4025  
mail@jescoamerica.com  
www.lutzjescoamerica.com

**M**

**McCrometer Inc.**

3255 W Stetson Ave.  
Hemet, CA 92545  
800-220-2279 • 951-652-6811 • Fax: 951-652-3078  
customerservice@mccrometer.com  
www.mccrometer.com

**Milwaukee Rubber Products, Inc.**

N 52 W 13319 Falls Creek Ct.  
Menomonee Falls, WI 53051  
800-325-3730 • 262-781-7888 • Fax: 262-781-1742  
sales@milwaukeeerubber.com  
www.milwaukeeerubber.com

**MoistTech Corp.**

1199 Tallevast Rd.  
Sarasota, FL 34243  
941-351-7870  
www.moisttech.com

**Mud Cat, Division of Ellicott Dredge Technologies**

1750 Madison Ave.  
New Richmond, WI 54017  
866-467-4010 • 913-642-5100 • Fax: 913-642-5119  
sales@mudcatdredge.com  
www.mudcatdredge.com



**Myron L Company**

2450 Impala Dr.  
Carlsbad, CA 92010  
760-438-2021 • Fax: 760-931-9189  
info@myronl.com  
www.myronl.com

**Ad on page 57**

**N**

**Nasco Whirl-Pak**

901 Janesville Ave.  
Fort Atkinson, WI 53538  
800-558-9595 • 920-568-5578 • Fax: 920-568-5778  
info@enasco.com  
www.enasco.com/whirlpak

**Ad on page 117**

**NEFCO Systems, Inc.**

8895 N Military Trail, Bldg. C, Ste. 100  
Palm Beach Gardens, FL 33410  
561-775-9303 • Fax: 561-775-6043  
sales@nefco.us  
www.nefco.us

**NETZSCH Pumps North America, LLC**

119 Pickering Way  
Exton, PA 19341  
610-363-8010 • Fax: 610-363-0971  
npa@netsch.com  
www.pumps.netsch.com



**North Carolina Rural Water Association**

PO Box 540  
 Welcome, NC 27374  
 336-731-6963 • Fax: 336-731-8589  
 info@ncrwa.com  
 www.ncrwa.com

**Ad on page 116**

**NozzTeq Inc.**

1949 Calumet St.  
 Clearwater, FL 33765  
 866-620-5915 • 727-223-4979 • Fax: 603-413-6744  
 info@nozzteq.com  
 www.nozzteq.com



**OMI Industries**

1 Corporate Dr., Ste. 100  
 Long Grove, IL 60047  
 800-662-6367 • Fax: 847-304-0989  
 www.omi-industries.com



**Ovivo USA, LLC**

2404 Rutland Dr.  
 Austin, TX 78758  
 512-834-6000 • Fax: 512-834-6039  
 info.us@ovivowater.com  
 www.ovivowater.com



**Oxbow Activated Carbon LLC**

2535 Jason Ct.  
 Oceanside, CA 92056  
 760-630-5724 • Fax: 760-630-9930  
 sales@oxbowactivatedcarbon.com  
 www.oxbowactivatedcarbon.com



**Park Process**

7015 Fairbanks N Houston Rd.  
 Houston, TX 77040  
 855-511-7275 • 713-849-7189 • Fax: 713-937-4254  
 rcaughman@parkprocess.com  
 www.parkprocess.com

**Ad on page 116**

**Parker Boiler Co.**

5930 Bandini Blvd.  
 Los Angeles, CA 90040  
 323-727-9800 • Fax: 323-722-2848  
 mleeming@parkerboiler.com  
 www.parkerboiler.com

**Parkson Corporation**

1401 W Cypress Creek Rd.  
 Ft. Lauderdale, FL 33309  
 888-727-5766 • Fax: 954-974-6182  
 technology@parkson.com  
 www.parkson.com

**Paxxo**

1924 Millard Farmer Rd.  
 Newnan, GA 30263  
 770-502-0055 • Fax: 770-502-0088  
 chris.pettigrew@paxxo.com  
 www.paxxo.com

**Peabody Engineering and Supply Inc.**

13435 Estelle St.  
 Corona, CA 98278  
 877-734-3759 • Fax: 951-734-4111  
 sales@4peabody.com  
 www.4peabody.com



**Penn Valley Pump Co., Inc.**

998 Easton Rd.  
 Warrington, PA 18976  
 800-311-3311 • 215-343-8750 • Fax: 215-343-8753  
 info@pennvalleypump.com  
 www.pennvalleypump.com

**Ad on page 41**

**Permastore**

Eye  
 Suffolk, IP23 7HS  
 England  
 011 44 1379870723  
 sales@permastore.com  
 www.permastore.com

**Philadelphia Gear - A Timken Brand**

901 East 8th Ave., Ste. 100  
 King of Prussia, PA 19406  
 800-766-5120 • 610-265-3000 • Fax: 610-337-5637  
 info@philagear.com  
 www.philagear.com

**Phoenix Contact**

586 Fulling Mill Rd.  
 Middletown, PA 17057  
 800-888-7388 • 717-944-1300  
 info@phoenixcon.com  
 www.phoenixcontact.com/usa\_home

**Pick Heaters, Inc.**

730 S Indiana Ave.  
 West Bend, WI 53095  
 262-338-1191 • Fax: 262-338-8489  
 info1@pickheaters.com  
 www.pickheaters.com

**Pittsburg Tank & Tower Co., Inc.**

PO Box 913  
 Henderson, KY 42419  
 270-826-9000 • Fax: 270-827-4417  
 pheltsley@watertank.com  
 www.watertank.com

**PMC Engineering**

11 Old Sugar Hollow Rd.  
 Danbury, CT 06810  
 203-792-8686 • Fax: 203-743-2051  
 sales@pmc1.com  
 www.pmc1.com

**PolyScience**

6600 W Touhy Ave.  
 Niles, IL 60714  
 800-229-7569 • 847-647-0611 • Fax: 847-647-1155  
 sales@polyscience.com  
 www.polyscience.com

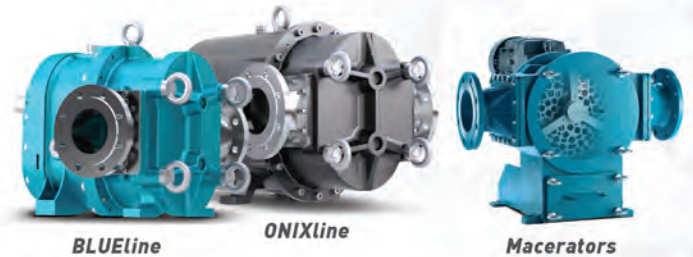
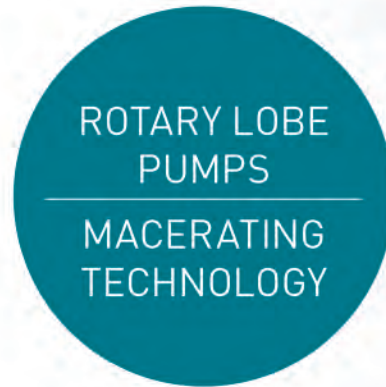

**CUSTOM FLUID HANDLING SOLUTIONS FOR THE WATER AND WASTEWATER INDUSTRIES.**

**Benefits:**

- + Flows up to 7,500 gpm
- + Pressures up to 180 psi
- + Viscosities to 1,000,000 cP
- + Low Shear Handling
- + Reversible Operation
- + Dry Running Capability
- + Solids Handling

**Applications:**

- + Lime Slurry
- + Sediment Pumps
- + Alum Sludge
- + Transfer Pump
- + Belt Press Feed



Visit us at ACE17 | June 11-14  
 Philadelphia, PA | Booth #2538

To learn more visit us at [www.boerger.com](http://www.boerger.com) or call 612.435.7300.



**Praxair, Inc.**  
7000 High Grove Blvd.  
Burr Ridge, IL 60527  
800-772-9247 • 630-320-4000 • Fax: 630-320-4508  
info@praxair.com  
www.praxair.com/wastewater

**PRD Tech, Inc.**  
1776 Mentor Ave., Ste. 400A  
Cincinnati, OH 45212  
513-673-3583  
rgovind837@aol.com  
www.prdtechinc.com



**Premier Tech Aqua**  
1 Avenue Premier  
Riviere-du-Loup, QC G5R 6C1  
Canada  
800-632-6356 • 418-867-8883 • Fax: 418-862-6642  
pta@premiertech.com  
www.premiertechaqua.com

**PRIMEX**  
PO Box 1708  
Detroit Lakes, MN 56501  
888-342-5753 • 218-847-1317 • Fax: 218-847-4617  
info@primexcontrols.com  
www.primexcontrols.com

**Proco Products, Inc.**  
2431 Wigwam Dr.  
Stockton, CA 95205  
800-344-3246 • 209-943-6088 • Fax: 209-943-0242  
sales@procoproducts.com  
www.procoproducts.com



**ProComSol, Ltd**  
13001 Athens Ave., Ste. 220  
Lakewood, OH 44107  
877-221-1551 • 216-221-1550 • Fax: 216-221-1554  
sales@procomsol.com  
www.procomsol.com  
**Ad on page 85**



**ProMinent Fluid Controls, Inc.**  
136 Industry Dr.  
Pittsburgh, PA 15275  
412-787-2484 • Fax: 412-787-0704  
sales@prominent.us  
www.prominent.us

**Pulsafeeder, Inc.**  
27101 Airport Rd.  
Punta Gorda, FL 33982  
800-333-6677 • 941-575-3800 • Fax: 941-575-4085  
ppgsptech@idexcorp.com  
www.pulsatron.com

**Pulsed Hydraulics, Inc.**

15 Oro Beach Dr.  
Oraville, WA 98844  
800-641-1726 • 425-785-3225  
info@phiwater.com  
www.phiwater.com  
**Ad on page 116**

**R**

**Rain for Rent**  
5101 Office Park Dr, Ste 100  
Bakersfield, CA 93309  
800-742-7246 • 661-399-9124  
info@rainforrent.com  
www.rainforrent.com



**Rebuild-It Service Group, LLC**  
6810 S 300 W Ste. 8  
Midvale, UT 84047  
888-709-5676 • Fax: 385-355-6989  
treburn@rebuild-it.com  
www.rebuild-it.com

**Red Meters**

6520 Pinecastle Blvd.  
Orlando, FL 32809  
407-337-0110  
hello@redmeters.com  
www.redmeters.com  
**Ad on page 116**

**Red Valve Co. / Tideflex Technologies**

600 N Bell Ave.  
Carnegie, PA 15106-4322  
412-279-0044 • Fax: 412-279-7878  
sales@redvalve.com  
www.redvalve.com  
**Ad on page 35**

**Rhino Linings Corporation**

9747 Businesspark Ave.  
San Diego, CA 92131  
800-747-6966 • 858-450-0441 • Fax: 858-450-6881  
sales@rhinolinnings.com  
www.rhinolinnings.com  
**Ad on page 19**

**RKI Instruments, Inc.**  
33248 Central Ave.  
Union City, CA 94587  
800-754-5165 • 510-441-5656 • Fax: 510-441-5650  
orders@rkiistruments.com  
www.rkiistruments.com

**Robuschi USA**

1800 Gardner Expressway  
Quincy, IL 62305  
866-428-4890 • Fax: 217-221-8780  
www.gardnerdenver.com/robuschi/  
**Ad on page 119**

**Ronk Electrical**

106 E State St.  
Nokomis, IL 62075  
800-221-7665 • 217-563-8333 • Fax: 217-563-8336  
sales@ronkelectrical.com  
www.ronkelectrical.com  
**Ad on page 116**

**RootX**

PO Box 7626  
Salem, OR 97303  
800-844-4974 • 503-364-2999 • Fax: 503-485-5229  
rootx@rootx.com  
www.rootx.com

**Roto-Mix, LLC**

2205 E Wyatt Earp Blvd.  
Dodge City, KS 67801  
620-225-1142 • Fax: 620-225-6370  
info@rotomix.com  
www.rotomix.com  
**Ad on page 93**



**Ruthman Companies**

1212 Streng St.  
Cincinnati, OH 45233  
859-824-3100 • Fax: 859-824-7248  
www.gusher.com/contact-us  
www.ruthmancompanies.com/ruthman-companies  
**Ad on page 37**

**RWL Water**

7135 Madison Ave. W  
Golden Valley, MN 55427  
800-879-3677 • 763-746-8400 • Fax: 763-746-8408  
info@rwlwater.com  
www.rwlwater.com

**S**

**SAF-T-FLO Chemical Injection**

4091 E La Palma, Ste. U  
Anaheim, CA 92807  
800-957-2383 • 714-632-3013 • Fax: 714-632-3350  
info@safflo.com  
www.safflo.com  
**Ad on page 47**



**Schwing Bioset, Inc.**  
350 SMC Dr.  
Somerset, WI 54025  
844-246-7381 • 715-247-3433 • Fax: 715-247-3438  
marketing@schwingbioset.com  
www.schwingbioset.com

**ScreenCo Systems LLC**

13235 Spur Rd.  
Genesee, ID 83832  
208-790-8770  
sales@screencosystems.com  
www.screencosystems.com  
**Ad on page 116**

**SEEPEx Inc.**

511 Speedway Dr.  
Enon, OH 45323  
937-864-7150 • Fax: 937-864-7157  
sales.us@seepex.com  
www.seepex.com  
**Ad on page 71**

**Sensaphone**

901 Tryens Rd.  
Aston, PA 19014  
877-373-2700 • 610-558-2700 • Fax: 610-558-0222  
contact@sensaphone.com  
www.sensaphone.com

**Sensorex**

11751 Markon Dr.  
Garden Grove, CA 92841  
800-835-4344 • 714-895-4344  
sales@sensorex.com  
www.sensorex.com

**Sewer Shield Composite LLC**

4702 E Virginia St.  
Mesa, AZ 85215  
480-830-9537  
info@sewershieldcomposites.com  
www.sewershieldcomposites.com

**Shand & Jurs**

5911 Butterfield Rd.  
Hillside, IL 60162  
708-236-6000 • Fax: 708-236-6006  
sales@ljtechnologies.com  
www.ljtechnologies.com  
**Ad on page 29**

**Sierra Environmental Technologies, LLC**

18545 Bridlegate Ln.  
Wildwood, MO 63069  
636-273-5189 • Fax: 636-273-4509  
dnokes@setodorcontrol.com  
www.setodorcontrol.com

**Sierra Instruments, Inc.**

5 Harris Ct., Bldg. L  
Monterey, CA 93940  
800-866-0200 • 831-373-0200 • Fax: 831-373-4402  
info@sierrainstruments.com  
www.sierrainstruments.com

**Simple Solutions Distributing**

6 Jacobs Rd.  
West Milford, NJ 07480  
866-667-8465 • 973-846-7817 • Fax: 973-858-0219  
sales@industrialodorcontrol.com  
www.IndustrialOdorControl.com  
**Ad on page 116**

**Singer Valve Inc.**

12850 87 Ave.  
Surrey, BC V3W 3H9  
Canada  
888-764-7858 • 604-594-5404 • Fax: 604-594-8845  
singer@singervalve.com  
www.singervalve.com  
**Ad on page 79**





**Smith & Loveless, Inc.**  
14040 Santa Fe Trail Dr.  
Lenexa, KS 66215  
800-898-9122 • 913-888-5201  
answers@smithandloveless.com  
www.smithandloveless.com

**SRS Crisafulli, Inc.**  
1610 Crisafulli Dr.  
Glendive, MT 59330  
800-442-7867 • 406-365-3393 • Fax: 406-365-8088  
srsc@crisafulli.com  
www.crisafullipumps.com

**Sulzer Pumps Solutions Inc.**  
140 Pond View Dr.  
Meriden, CT 06450  
800-525-7790 • 203-238-2700 • Fax: 203-238-0738  
info.abs.usa@sulzer.com  
www.sulzer.com

**Sunbelt Rentals**

2341 Deerfield Dr.  
Fort Mill, SC 29715  
800-736-2504  
www.sunbeltrentals.com

Ad on page 27

**Superior Tank Co., Inc.**

9500 Lucas Ranch Rd.  
Rancho Cucamonga, CA 91730  
877-974-4438 • 909-912-0580 • Fax: 909-912-0585  
marketing@superiortank.com  
www.superiortank.com

Ad on page 75

**Sure Flow Products, LLC**

28265 Beck Rd., Ste. C-11  
Wixom, MI 48393  
248-380-3569 • Fax: 248-380-3568  
sales@sureflowproducts.com  
www.flowmetersource.com

**T**

**Tapflo**

Filaregatan 4  
S-442 34 Kungv/Slv  
Sweden  
004630363390  
sales@tapflo.com  
www.tapflo.com



**Thermal Edge Inc.**

TEMPERATURE CONTROL SOLUTIONS FOR ELECTRICAL ENCLOSURES

**Thermal Edge Inc.**  
1751 Hurd Dr.  
Irving, TX 75038  
888-580-0202 • 972-580-0200 • Fax: 972-580-0202  
thermalinfo@thermal-edge.com  
www.thermal-edge.com

**Trident Processes LLC**

446 Harrison St, Unit #81D  
Sumas, WA 98295  
800-799-3740 • 604-330-2500  
info@tridentprocesses.com  
www.tridentprocesses.com

**Trihedral Engineering Limited**

1160 Bedford Hwy., Ste. 400  
Bedford, NS B4A 1C1  
Canada  
800-463-2783 • 902-835-1575 • Fax: 902-835-0369  
pcooke@trihedral.com  
www.trihedral.com

**Triplepoint Environmental**

1140 W Lake St.  
Oak Park, IL 60301  
800-654-9307 • Fax: 312-957-4712  
info@triplepointwater.com  
www.tpev.com

**Tuthill Vacuum & Blower Systems**

4840 W Kearney St.  
Springfield, MO 65803  
800-825-6937 • 417-865-8715 • Fax: 417-865-2950  
vacuum@tuthill.com  
www.tuthillvacuumblower.com

**U**

**U.S. Submergent Technologies LLC**

235 N Orange Ave., Ste. 201  
Sarasota, FL 34236  
844-765-7866 • 941-444-1440 • Fax: 941-219-3080  
info@ussubmergent.com  
www.ussubmergent.com



**U.S. Water Services Corporation**

4939 Cross Bayou Blvd.  
New Port Richey, FL 34652  
866-753-8292 • 515-269-2336 • Fax: 727-848-7701  
info@uswatercorp.net  
www.uswatercorp.com

**Unison Solutions, Inc.**

5451 Chavenelle Rd.  
Dubuque, IA 52002  
563-585-0967 • Fax: 563-585-0970  
sales@unisonsolutions.com  
www.unisonsolutions.com

**MYRON L<sup>®</sup> COMPANY**  
Water Quality Instrumentation  
Accuracy • Reliability • Simplicity  
... Since 1957

Download on the App Store

Bluetooth

www.myronl.com  
760-438-2021

MADE IN USA

ACE 17 Booth 1910



**USALCO, LLC**

2601 Cannery Ave.  
Baltimore, MD 21226  
800-882-3883 • 410-918-2230  
ctesone@usalco.com  
www.usalco.com

**Ad on page 81**

**USP Technologies (US Peroxide)**

900 Circle 75 Pkwy., Ste. 1330  
Atlanta, GA 30339  
877-346-4262 • 404-352-6070 • Fax: 404-352-6077  
info@uspstechnologies.com  
www.usptechnologies.com

**Uticom Systems, Inc.**

109 Independence Way  
Coatesville, PA 19320  
800-548-5321 • 610-857-2655 • Fax: 610-857-2986  
graphics@uticom.net  
www.uticom.net

Pure, safe water.



Always.

**UV Pure Technologies, Inc.**

60 Venture Dr. Unit 7  
Toronto, ON M1B 3S4  
Canada  
888-407-9997 • 416-208-9884 • Fax: 416-208-5808  
info@uvpure.com  
www.uvpure.com

**V**

**VAF Filtration Systems**

5270 Marshall St.  
Arvada, CO 80002  
303-425-4242 • Fax: 303-425-0112  
sales.vaf@voqua.com  
www.vafusa.com

**ValveUSA**

786-571-8258  
info@valveusa.com  
www.valveusa.com

**Van London Co.**

10540 Rockley Rd.  
Houston, TX 77099  
800-522-7920 • 832-456-6641 • Fax: 832-456-6642  
anna@vanlondon.com  
www.vanlondon.com

**VaraCorp LLC**

13501 Ranch Rd 12 Ste. 103  
Wimberley, TX 78676  
800-801-6685 • 512-847-5026 • Fax: 866-611-6703  
info@varacorp.com  
www.varacorp.com



**Varec Biogas**

5362 Oceanus Dr., Ste. A  
Huntington Beach, CA 92649  
866-424-6427 • Fax: 714-952-2701  
info@varec-biogas.com  
www.varec-biogas.com

**Vaughan Company, Inc.**

364 Monte-Elma Rd.  
Montesano, WA 98563  
888-249-2467 • 360-249-4042 • Fax: 360-249-6155  
info@chopperpumps.com  
www.chopperpumps.com

**Ad on page 120**

**VFOLD INC.**

15700 Robin's Hill Rd., Unit #2  
London, ON N5V 0A4  
Canada  
877-818-3653 • Fax: 519-659-6941  
sales@vfoldinc.com  
www.vfoldinc.com

**W**

**Wako Chemicals USA, Inc.**

1600 Bellwood Rd.  
Richmond, VA 23237  
877-714-1920 • 804-714-1920 • Fax: 804-271-7791  
www.wakousa.com

**Walker Process Equipment,  
A Div. of McNish Corp.**

840 N Russell Ave.  
Aurora, IL 60506  
800-992-5537 • 630-892-7921 • Fax: 630-892-7951  
walker.process@walker-process.com  
www.walker-process.com

**Ad on page 87**



**Wastecorp Pumps**

PO Box 70  
Grand Island, New York 14072  
888-829-2783 • 201-445-2882 • Fax: 888-888-3320  
info@wastecorp.com  
www.wastecorp.com

**Wastewater Depot, LLC**

4446 State Rte. 132  
Batavia, OH 45103  
513-732-0129 • Fax: 513-735-1485  
info@wastewaterdepot.com  
www.wastewaterdepot.com

**Watson-Marlow Fluid Technology Group**

37 Upton Technology Park Dr.  
Wilmington, MA 01887  
800-282-8823 • 978-658-6168 • Fax: 978-658-0041  
support@wmpg.us  
www.watson-marlow.com

**Ad on page 53**

**WEG Electric Corp**

6655 Sugarloaf Pkwy.  
Duluth, GA 30097  
800-275-4934  
info-us@weg.net  
www.weg.net/us

**Weidmuller**

821 Southlake Blvd.  
Richmond, VA 23236  
800-849-9343 • Fax: 804-379-2593  
info@weidmuller.com  
www.weidmuller.com

**Weir Specialty Pumps (WEMCO)**

440 West 800 S  
Salt Lake City, UT 84101  
801-359-8731 • Fax: 801-530-7828  
wemco@mail.weir  
www.global.weir

**WesTech Engineering**

3665 S West Temple  
Salt Lake City, UT 84115  
801-265-1000 • Fax: 801-265-1080  
info@westech-inc.com  
www.westech-inc.com

**Z**

**Zoeller Pump Company**

3649 Cane Run Rd.  
Louisville, KY 40211  
800-928-7867 • 502-778-2731  
www.zoeller.com

LISTINGS BY CATEGORY

**Activated Carbon Services**



**Activated Carbon Services - PACS**

Coraopolis, PA  
800-367-2587 • 724-457-6576  
henry@pacslabs.com  
www.pacslabs.com

**Activated Carbon/Systems**

**Activated Carbon Services - PACS**

Coraopolis, PA  
800-367-2587 • 724-457-6576  
henry@pacslabs.com  
www.pacslabs.com

**AdEdge Water Technologies, LLC**

Duluth, GA  
866-823-3343 • 678-835-0052 • Fax: 678-835-0057  
sales@adedge technologies.com  
www.adedgetech.com

**Ad on page 25**

**CEI - Carbon Enterprises Inc.**

Circleville, OH  
800-344-5770 • Fax: 888-204-9656  
info@ceicompanies.com  
www.ceifiltration.com

**Graver Technologies**

Glasgow, DE  
302-731-1700 • Fax: 302-369-0938  
info@gravertech.com  
www.gravertech.com

**KCH Engineered Systems**

Forest City, NC  
828-245-9836  
khankinson@kchservices.com  
www.kchservices.com



**Oxbow Activated Carbon LLC**

Oceanside, CA  
760-630-5724 • Fax: 760-630-9930  
sales@oxbowactivatedcarbon.com  
www.oxbowactivatedcarbon.com

**Sierra Environmental Technologies, LLC**

Wildwood, MO  
636-273-5189 • Fax: 636-273-4509  
dnakes@setodorcontrol.com  
www.setodorcontrol.com

**Simple Solutions Distributing**

West Milford, NJ  
866-667-8465 • 973-846-7817 • Fax: 973-858-0219  
sales@industrialodorcontrol.com  
www.IndustrialOdorControl.com

**Ad on page 116**

**Unison Solutions, Inc.**

Dubuque, IA  
563-585-0967 • Fax: 563-585-0970  
sales@unisonsolutions.com  
www.unisonsolutions.com

**WesTech Engineering**

Salt Lake City, UT  
801-265-1000 • Fax: 801-265-1080  
info@westech-inc.com  
www.westech-inc.com



**Activated Sludge Systems**

**Aeration Industries International**

Chaska, MN  
800-328-8287 • 952-448-6789 • Fax: 952-448-7293  
aai@aireo2.com  
www.aireo2.com

**Aqua Operations, Inc.**

Bakersfield, CA  
888-746-6535 • 661-331-1181 • Fax: 661-833-1861  
childerbrand@aquaoptions.com  
www.aquaoptions.com

**Bio-Microbics, Inc.**

Shawnee, KS  
800-753-3278 • 913-422-0707 • Fax: 913-422-0808  
sales@biomicrobics.com  
www.biomicrobics.com

**Enterprise Specialty Products**

Laurens, SC  
864-984-7700 • Fax: 864-984-2241  
www.enterprisesp.com

**Fluidyne Corporation**

Cedar Falls, IA  
319-266-9967 • Fax: 319-277-6034  
fluidyne@fluidynecorp.com  
www.fluidynecorp.com

**Parkson Corporation**

Ft. Lauderdale, FL  
888-727-5766 • Fax: 954-974-6182  
technology@parkson.com  
www.parkson.com

**Smith & Loveless, Inc.**

Lenexa, KS  
800-898-9122 • 913-888-5201  
answers@smithandloveless.com  
www.smithandloveless.com

**Trident Processes LLC**

Sumas, WA  
800-799-3740 • 604-330-2500  
info@tridentprocesses.com  
www.tridentprocesses.com

**VaraCorp LLC**

Wimberley, TX  
800-801-6685 • 512-847-5026 • Fax: 866-611-6703  
info@varacorp.com  
www.varacorp.com

**Aeration Equipment/  
Systems**

**Aeration Industries International**

Chaska, MN  
800-328-8287 • 952-448-6789 • Fax: 952-448-7293  
aai@aireo2.com  
www.aireo2.com

**Aerzen USA**

Coatesville, PA  
610-380-0244  
aerzen@aerzenusa.com  
www.aerzen.com/en-us/

Ad on page 45



**Airmaster Aerator L.L.C.**

DeRidder, LA  
888-813-3680 • 337-463-6567 • Fax: 337-463-9119  
deanc@airmasteraerator.com  
www.airmasteraerator.com

Ad on page 4

**All-Star Products**  
Memphis, TN  
800-431-8258 • 901-755-9613  
edwardb@all-star-usa.com  
www.all-star-usa.com  
Ad on page 21

**American Pleasure Products, Inc.**

Rose City, MI  
989-685-2697 • Fax: 989-685-8484  
info@aquacycleusa.com  
www.aquacycleusa.com

Ad on page 77



**Aqua-Aerobic Systems, Inc.**

Loves Park, IL  
800-940-5008 • 815-654-2501 • Fax: 815-654-2508  
solutions@aquaaerobic.com  
www.aquaaerobic.com

Ad on page 11

**AQUATURBO SYSTEMS, Inc.**

Springdale, AR  
479-927-1300 • Fax: 479-927-0700  
ats@aquaturbo.com  
www.aquaturbousa.com

**Bio-Microbics, Inc.**

Shawnee, KS  
800-753-3278 • 913-422-0707 • Fax: 913-422-0808  
sales@biomicrobics.com  
www.biomicrobics.com



**Bradley Innovation Group**

Indianapolis, IN  
317-726-6615  
sales@big-h2o.com  
www.big-h2o.com

**Brown Bear Corporation**

Corning, IA  
641-322-4220 • Fax: 641-322-3527  
sales@brownbearcorp.com  
www.brownbearcorp.com

**Busch Vacuum Pumps and Systems**

Virginia Beach, VA  
800-872-7867 • 757-463-7800 • Fax: 757-463-7407  
marketing@buschusa.com  
www.buschusa.com



**Wastemaster™  
Combined Pre-Treatment Plant  
Complete Above-Ground  
Headworks  
No Civil Works Required**



**Remove Solids, Grit & Grease  
in One Compact Unit.**

See a full size production unit  
at the Enviro-Care Booth 1342  
at WEFTEC Chicago.

The most trusted brands in water & wastewater



A WAMGROUP® Company

ecsales@enviro-care.com • 815-636-8306

**Delta M Corporation**  
Oak Ridge, TN  
800-922-0083 • 865-483-1569 • Fax: 865-483-1142  
sales@deltamcorp.com  
www.deltamcorp.com

**Eurus Blower, Inc.**  
Wheaton, IL  
630-221-8282 • Fax: 630-221-1002  
tomh@eurusblower.com  
www.eurusblower.com

**Ad on page 95**

**Fluidyne Corporation**  
Cedar Falls, IA  
319-266-9967 • Fax: 319-277-6034  
fluidyne@fluidynecorp.com  
www.fluidynecorp.com



**Greener Planet Systems**  
Monroe, IA  
888-669-1787 • 517-719-2580  
brianm@greenerplanetsystems.com  
www.greenerplanetsystems.com

**Howden Roots**  
Connersville, IN  
800-557-6687 • 765-827-9200 • Fax: 765-827-9317  
connersville.customercare@howden.com  
www.howdenroots.com

**KCH Engineered Systems**  
Forest City, NC  
828-245-9836  
khankinson@kchservices.com  
www.kchservices.com

**Lakeside Equipment Corporation**  
Bartlett, IL  
630-837-5640 • Fax: 630-837-5647  
sales@lakeside-equipment.com  
www.lakeside-equipment.com

**Ad on page 3**



**Ovivo USA, LLC**  
Austin, TX  
512-834-6000 • Fax: 512-834-6039  
info.us@ovivowater.com  
www.ovivowater.com

**Parkson Corporation**  
Ft. Lauderdale, FL  
888-727-5766 • Fax: 954-974-6182  
technology@parkson.com  
www.parkson.com

**Praxair, Inc.**  
Burr Ridge, IL  
800-772-9247 • 630-320-4000 • Fax: 630-320-4508  
info@praxair.com  
www.praxair.com/wastewater

**Red Valve Co. / Tideflex Technologies**  
Carnegie, PA  
412-279-0044 • Fax: 412-279-7878  
sales@redvalve.com  
www.redvalve.com

**Ad on page 35**

**RWL Water**  
Golden Valley, MN  
800-879-3677 • 763-746-8400 • Fax: 763-746-8408  
info@rwlwater.com  
www.rwlwater.com

**Sierra Instruments, Inc.**  
Monterey, CA  
800-866-0200 • 831-373-0200 • Fax: 831-373-4402  
info@sierrainstruments.com  
www.sierrainstruments.com

**Smith & Loveless, Inc.**  
Lenexa, KS  
800-898-9122 • 913-888-5201  
answers@smithandloveless.com  
www.smithandloveless.com

**Sulzer Pumps Solutions Inc.**  
Meriden, CT  
800-525-7790 • 203-238-2700 • Fax: 203-238-0738  
info.abs.usa@sulzer.com  
www.sulzer.com

**Triplepoint Environmental**  
Oak Park, IL  
800-654-9307 • Fax: 312-957-4712  
info@triplepointwater.com  
www.tpev.com



**Tuthill Vacuum & Blower Systems**  
Springfield, MO  
800-825-6937 • 417-865-8715 • Fax: 417-865-2950  
vacuum@tuthill.com  
www.tuthillvacuumblower.com

**VaraCorp LLC**  
Wimberley, TX  
800-801-6685 • 512-847-5026 • Fax: 866-611-6703  
info@varacorp.com  
www.varacorp.com

**WesTech Engineering**  
Salt Lake City, UT  
801-265-1000 • Fax: 801-265-1080  
info@westech-inc.com  
www.westech-inc.com

## Aerobic Treatment

**Aeration Industries International**  
Chaska, MN  
800-328-8287 • 952-448-6789 • Fax: 952-448-7293  
aii@aireo2.com  
www.aireo2.com

**Aerzen USA**  
Coatesville, PA  
610-380-0244  
aerzen@aerzenusa.com  
www.aerzen.com/en-us/

**Ad on page 45**

**Airmaster Aerator LLC**  
DeRidder, LA  
888-813-3680 • 337-463-6567 • Fax: 337-463-9119  
deanc@airmasteraerator.com  
www.airmasteraerator.com

**Ad on page 4**

**Anue Water Technologies, Inc.**  
Oceanside, CA  
760-727-2683  
info@anuewater.com  
www.anuewater.com

**AQUATURBO SYSTEMS, Inc.**  
Springdale, AR  
479-927-1300 • Fax: 479-927-0700  
ats@aquaturbo.com  
www.aquaturbousa.com

**Bionetix International**  
Ste-Anne-de-Bellevue, QC  
Canada  
514-457-2914 • Fax: 514-457-3589  
info@bionetix.ca  
www.bionetix-international.com

**Bradley Innovation Group**  
Indianapolis, IN  
317-726-6615  
sales@big-h2o.com  
www.big-h2o.com

**Byo-Gon, Inc.**  
Charleston, SC  
888-796-4661 • 843-822-3415 • Fax: 843-606-6318  
info@byogon.com  
www.byogon.com

**Ad on page 117**

**Delta M Corporation**  
Oak Ridge, TN  
800-922-0083 • 865-483-1569 • Fax: 865-483-1142  
sales@deltamcorp.com  
www.deltamcorp.com

**Enterprise Specialty Products**  
Laurens, SC  
864-984-7700 • Fax: 864-984-2241  
www.enterprisesp.com

**Environetics, Inc.**  
Lockport, IL  
815-838-8331 • Fax: 815-838-8336  
info@environeticsinc.com  
www.environeticsinc.com

**Eurus Blower, Inc.**  
Wheaton, IL  
630-221-8282 • Fax: 630-221-1002  
tomh@eurusblower.com  
www.eurusblower.com

**Ad on page 95**

**F & V Operations and Resource Management**  
Grand Rapids, MI  
888-773-8806 • 616-588-2900 • Fax: 616-977-1005  
bselover@fv-operations.com  
www.fv-operations.com

**Greener Planet Systems**  
Monroe, IA  
888-669-1787 • 517-719-2580  
brianm@greenerplanetsystems.com  
www.greenerplanetsystems.com

**Headworks International, Inc.**  
Houston, TX  
713-647-6667 • Fax: 713-647-0999  
hw@headworksintl.com  
www.headworksintl.com



**Ovivo USA, LLC**  
Austin, TX  
512-834-6000 • Fax: 512-834-6039  
info.us@ovivowater.com  
www.ovivowater.com

**Praxair, Inc.**  
Burr Ridge, IL  
800-772-9247 • 630-320-4000 • Fax: 630-320-4508  
info@praxair.com  
www.praxair.com/wastewater

**PRD Tech, Inc.**  
Cincinnati, OH  
513-673-3583  
rgovind837@aol.com  
www.prdtechinc.com

**RWL Water**  
Golden Valley, MN  
800-879-3677 • 763-746-8400 • Fax: 763-746-8408  
info@rwlwater.com  
www.rwlwater.com

**Smith & Loveless, Inc.**  
Lenexa, KS  
800-898-9122 • 913-888-5201  
answers@smithandloveless.com  
www.smithandloveless.com

**Triplepoint Environmental**  
Oak Park, IL  
800-654-9307 • Fax: 312-957-4712  
info@triplepointwater.com  
www.tpev.com

**VaraCorp LLC**  
Wimberley, TX  
800-801-6685 • 512-847-5026 • Fax: 866-611-6703  
info@varacorp.com  
www.varacorp.com

## Alarm Systems/ Components

**BinMaster Level Controls**  
Lincoln, NE  
800-278-4241 • 402-434-9102 • Fax: 402-434-9133  
info@binmaster.com  
www.binmaster.com

**Ad on page 117**

**Harwil Corp.**  
Oxnard, CA  
805-988-6800 • Fax: 805-988-6804  
sales@harwil.com  
www.harwil.com



**PRIMEX**  
Detroit Lakes, MN  
888-342-5753 • 218-847-1317 • Fax: 218-847-4617  
info@primexcontrols.com  
www.primexcontrols.com

**Sensaphone**  
Aston, PA  
877-373-2700 • 610-558-2700 • Fax: 610-558-0222  
contact@sensaphone.com  
www.sensaphone.com

**Trihedral Engineering Limited**  
Bedford, NS  
Canada  
800-463-2783 • 902-835-1575 • Fax: 902-835-0369  
pcooke@trihedral.com  
www.trihedral.com



**Algae Control**

**Airmaster Aerator LLC**

DeRidder, LA  
888-813-3680 • 337-463-6567 • Fax: 337-463-9119  
deanc@airmasteraerator.com  
www.airmasteraerator.com  
**Ad on page 4**

**Amiad USA**

Mooreville, NC  
704-662-3133 • Fax: 704-662-3155  
infousa@amiad.com  
www.amiadusa.com

**Bionetix International**

Ste-Anne-de-Bellevue, QC  
Canada  
514-457-2914 • Fax: 514-457-3589  
info@bionetix.ca  
www.bionetix-international.com

**Bradley Innovation Group**

Indianapolis, IN  
317-726-6615  
sales@big-h2o.com  
www.big-h2o.com

**Environetics, Inc.**

Lockport, IL  
815-838-8331 • Fax: 815-838-8336  
info@environeticsinc.com  
www.environeticsinc.com

**Ford Hall Company, Inc.**

Richmond, KY  
859-624-1077 • Fax: 859-624-3320  
sperry@fordhall.com  
www.weir-wolf.com  
**Ad on page 79**



Geomembrane Technologies Inc.

**Geomembrane Technologies Inc.**

Fredericton, NB  
Canada  
855-484-4630 • 506-452-7304 • Fax: 506-452-6625  
covers@gticovers.com  
www.gticovers.com



**GillTrading.com, Inc./WeirWasher, ACS**

Beaverton, OR  
866-447-2496 • 503-628-0197 • Fax: 503-646-9293  
brentgill@gilltrading.com  
www.gilltrading.com

**LANXESS / International Dioxide, Inc.**

North Kingstown, RI  
401-295-8800 • Fax: 401-295-7108  
adox@lanxess.com  
www.lanxess.com

**NEFCO Systems, Inc.**

Palm Beach Gardens, FL  
561-775-9303 • Fax: 561-775-6043  
sales@nefco.us  
www.nefco.us

**Anaerobic Treatment**

**AQUATURBO SYSTEMS, Inc.**

Springdale, AR  
479-927-1300 • Fax: 479-927-0700  
ats@aquaturbo.com  
www.aquaturbousa.com

**Bio-Microbics, Inc.**

Shawnee, KS  
800-753-3278 • 913-422-0707 • Fax: 913-422-0808  
sales@biomicrobics.com  
www.biomicrobics.com

**Bionetix International**

Ste-Anne-de-Bellevue, QC  
Canada  
514-457-2914 • Fax: 514-457-3589  
info@bionetix.ca  
www.bionetix-international.com

**Boerger, LLC**

Chanhausen, MN  
612-435-7300 • Fax: 612-435-7301  
america@boerger.com  
www.boerger.com  
**Ad on page 55**

**Byo-Gon, Inc.**

Charleston, SC  
888-796-4661 • 843-822-3415 • Fax: 843-606-6318  
info@byogon.com  
www.byogon.com  
**Ad on page 117**

**Enterprise Specialty Products**

Laurens, SC  
864-984-7700 • Fax: 864-984-2241  
www.enterprisesp.com

**Environetics, Inc.**

Lockport, IL  
815-838-8331 • Fax: 815-838-8336  
info@environeticsinc.com  
www.environeticsinc.com

**Evoqua Water Technologies LLC**

Warrendale, PA  
800-466-7873 • 724-772-0044  
municipalmarketing@evoqua.com  
www.evoqua.com

**F & V Operations and Resource Management**

Grand Rapids, MI  
888-773-8806 • 616-588-2900 • Fax: 616-977-1005  
bselover@fv-operations.com  
www.fv-operations.com

**Greener Planet Systems**

Monroe, IA  
888-669-1787 • 517-719-2580  
brianm@greenerplanetsystems.com  
www.greenerplanetsystems.com

THE  
**Best Blower**  
WE HAVE **Ever** MADE

Introducing the CycloBlower H.E.

- Game changing patented design
- Best-in-class energy efficiency
- Built with the best-of-the-best components
- Flexible options & installation

[www.gardnerdenver.com/gdproducts](http://www.gardnerdenver.com/gdproducts)

©2017 Gardner Denver. All rights reserved.

**Gardner  
Denver**

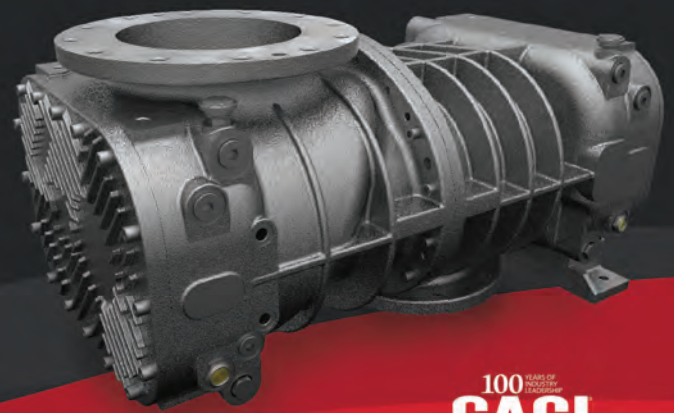

**Headworks International, Inc.**  
Houston, TX  
713-647-6667 • Fax: 713-647-0999  
hw@headworksintl.com  
www.headworksintl.com

**JDV Equipment Corporation**  
Dover, NJ  
973-366-6556 • Fax: 973-366-3193  
sales@jdvequipment.com  
www.jdvequipment.com  
**Ad on page 83**



**Ovivo USA, LLC**  
Austin, TX  
512-834-6000 • Fax: 512-834-6039  
info.us@ovivowater.com  
www.ovivowater.com

**Permastore**  
Suffolk  
England  
011 44 1379870723  
sales@permastore.com  
www.permastore.com

**Pick Heaters, Inc.**  
West Bend, WI  
262-338-1191 • Fax: 262-338-8489  
info@pickheaters.com  
www.pickheaters.com

**PRD Tech**  
Innovative Technologies For A Cleaner Environment

**PRD Tech, Inc.**  
Cincinnati, OH  
513-673-3583  
rgovind837@aol.com  
www.prdtechinc.com

**Sierra Environmental Technologies, LLC**  
Wildwood, MO  
636-273-5189 • Fax: 636-273-4509  
dnokes@setodorcontrol.com  
www.setodorcontrol.com

**Walker Process Equipment,  
A Div. of McNish Corp.**  
Aurora, IL  
800-992-5537 • 630-892-7921 • Fax: 630-892-7951  
walker.process@walker-process.com  
www.walker-process.com  
**Ad on page 87**

## Association

**Activated Carbon Services - PACS**  
Coraopolis, PA  
800-367-2587 • 724-457-6576  
henry@pacslabs.com  
www.pacslabs.com

**American Water Works Association**  
Denver, CO  
800-926-7337 • Fax: 303-347-0804  
www.awwa.org  
**Ad on page 65**

**NC RWA**  
TRAINING SUPPORT  
**North Carolina Rural Water Association**  
Welcome, NC  
336-731-6963 • Fax: 336-731-8589  
info@ncrwa.com  
www.ncrwa.com  
**Ad on page 116**

## Automation/Optimization

**Data Flow Systems, Inc.**  
Melbourne, FL  
321-259-5009 • Fax: 321-259-4006  
info@dataflowsys.com  
www.dataflowsys.com

**ElectroSwitch Corporation**  
Weymouth, MA  
781-335-5200  
info@electroswitch.com  
www.electroswitch.com

**EMERSON**  
**Emerson Automation Solutions**  
Pittsburgh, PA  
800-445-9723 • 412-963-4000  
powerwater@emerson.com  
www.emerson.com/water

**Ford Hall Company, Inc.**  
Richmond, KY  
859-624-1077 • Fax: 859-624-3320  
sperry@fordhall.com  
www.weir-wolf.com  
**Ad on page 79**

**GillTrading.com, Inc./WeirWasher, ACS**  
Beaverton, OR  
866-447-2496 • 503-628-0197 • Fax: 503-646-9293  
brentgill@gilltrading.com  
www.gilltrading.com



**Hach**  
Loveland, CO  
800-227-4224 • 970-669-3050  
orders@hach.com  
www.hach.com  
**Ad on page 5**

**Hydromantis Environmental  
Software Solutions, Inc.**  
Hamilton, ON  
Canada  
905-522-0012 • Fax: 905-522-0031  
info@hydromantis.com  
www.hydromantis.com

**McCrometer Inc.**  
Hemet, CA  
800-220-2279 • 951-652-6811 • Fax: 951-652-3078  
customerservice@mccrometer.com  
www.mccrometer.com

**Phoenix Contact**  
Middletown, PA  
800-888-7388 • 717-944-1300  
info@phoenixcon.com  
www.phoenixcontact.com/usa\_home

**Sierra Instruments, Inc.**  
Monterey, CA  
800-866-0200 • 831-373-0200 • Fax: 831-373-4402  
info@sierrainstruments.com  
www.sierrainstruments.com

**Thermal Edge Inc.**  
Irving, TX  
888-580-0202 • 972-580-0200 • Fax: 972-580-0202  
thermalinfo@thermal-edge.com  
www.thermal-edge.com

**Trihedral Engineering Limited**  
Bedford, NS  
Canada  
800-463-2783 • 902-835-1575 • Fax: 902-835-0369  
pcooke@trihedral.com  
www.trihedral.com



**Weidmüller**  
Richmond, VA  
800-849-9343 • Fax: 804-379-2593  
info@weidmuller.com  
www.weidmuller.com

## Bacteria/Enzymes

**Bio-Microbics, Inc.**  
Shawnee, KS  
800-753-3278 • 913-422-0707 • Fax: 913-422-0808  
sales@biomicrobics.com  
www.biomicrobics.com

**Bionetix International**  
Ste-Anne-de-Bellevue, QC  
Canada  
514-457-2914 • Fax: 514-457-3589  
info@bionetix.ca  
www.bionetix-international.com

**Byo-Gon, Inc.**  
Charleston, SC  
888-796-4661 • 843-822-3415 • Fax: 843-606-6318  
info@byogon.com  
www.byogon.com  
**Ad on page 117**

**Greener Planet Systems**  
Monroe, IA  
888-669-1787 • 517-719-2580  
brianm@greenerplanetsystems.com  
www.greenerplanetsystems.com

**Hawkins Water Treatment Group**  
Roseville, MN  
800-328-5460 • 612-331-6910 • Fax: 612-331-5304  
laura.eilek@hawkinsinc.com  
www.hawkinsinc.com



**In-Pipe Technology**  
Wood Dale, IL  
888-325-5033 • 630-509-2488 • Fax: 630-509-2490  
jwilliams@in-pipe.com  
www.in-pipe.com

## Bins/Hoppers/Silos

**BinMaster Level Controls**  
Lincoln, NE  
800-278-4241 • 402-434-9102 • Fax: 402-434-9133  
info@binmaster.com  
www.binmaster.com  
**Ad on page 117**

**Bright Technologies,  
Division of Sebright Products, Inc.**  
Hopkins, MI  
800-253-0532 • 269-793-7183 • Fax: 269-793-4022  
julie@brightbeltpress.com  
www.brightbeltpress.com  
**Ad on page 83**

**Hawk Measurement**  
Lawrence, MA  
888-429-5538 • 978-304-3000 • Fax: 978-304-1462  
info@hawkmeasure.com  
www.hawkmeasure.com

**Permastore**  
Suffolk  
England  
011 44 1379870723  
sales@permastore.com  
www.permastore.com

**Schwing Bioset, Inc.**  
Somerset, WI  
844-246-7381 • 715-247-3433 • Fax: 715-247-3438  
marketing@schwingbioset.com  
www.schwingbioset.com

## Biogas CHP Cogeneration Systems

**JDV Equipment Corporation**  
Dover, NJ  
973-366-6556 • Fax: 973-366-3193  
sales@jdvequipment.com  
www.jdvequipment.com  
**Ad on page 83**

**Unison Solutions, Inc.**  
Dubuque, IA  
563-585-0967 • Fax: 563-585-0970  
sales@unisonsolutions.com  
www.unisonsolutions.com

**Varec**  
BIOGAS  
**Varec Biogas**  
Huntington Beach, CA  
866-424-6427 • Fax: 714-952-2701  
info@varec-biogas.com  
www.varec-biogas.com



**Biogas Safety/  
Handling Equipment**



**Varec Biogas**  
Huntington Beach, CA  
866-424-6427 • Fax: 714-952-2701  
info@varec-biogas.com  
www.varec-biogas.com

**Biological Stimulants**

**Bionetix International**  
Ste-Anne-de-Bellevue, QC  
Canada  
514-457-2914 • Fax: 514-457-3589  
info@bionetix.ca  
www.bionetix-international.com

**Byo-Gon, Inc.**  
Charleston, SC  
888-796-4661 • 843-822-3415 • Fax: 843-606-6318  
info@byogon.com  
www.byogon.com  
**Ad on page 117**

**Greener Planet Systems**  
Monroe, IA  
888-669-1787 • 517-719-2580  
brianm@greenerplanetsystems.com  
www.greenerplanetsystems.com

**Biosolids Treatment/  
Application**



**Anue Water Technologies, Inc.**  
Oceanside, CA  
760-727-2683  
info@anuewater.com  
www.anuewater.com

**BCR Environmental Corporation**  
Jacksonville, FL  
904-819-9170 • Fax: 904-998-3828  
marketing@bcrenv.com  
www.bcrenv.com

**BDP Industries**  
Greenwich, NY  
518-695-6851 • Fax: 518-695-5417  
dan@bdpindustries.com  
www.bdpindustries.com  
**Ad on page 73**

**Boerger, LLC**  
Chanhassen, MN  
612-435-7300 • Fax: 612-435-7301  
america@boerger.com  
www.boerger.com  
**Ad on page 55**

**Brown Bear Corporation**  
Corning, IA  
641-322-4220 • Fax: 641-322-3527  
sales@brownbearcorp.com  
www.brownbearcorp.com

**Charter Machine Company**  
Metuchen, NJ  
732-548-4400  
walterk@chartermachine.com  
www.chartermachine.com

**CNP-Technology Water and Biosolids Corp.**  
Kenosha, WI  
262-764-3651 • Fax: 262-764-8705  
info@cnp-tec.com  
www.cnp-tec.com  
**Ad on page 85**

**CST Industries, Inc.**  
Kansas City, MT  
913-621-3700  
sales@cstindustries.com  
www.cstindustries.com



**DRYCAKE**  
Vancouver, BC  
Canada  
877-379-2253 • 604-535-2238  
sales@drycake.com  
www.drycake.com

**FKC Co., Ltd.**  
Port Angeles, WA  
360-452-9472 • Fax: 360-452-6880  
mail@fkcscrewpress.com  
www.fkcscrewpress.com

**Flottweg Separation Technology, Inc.**  
Independence, KY  
859-448-2331 • Fax: 859-448-2333  
sales@flottweg.net  
www.flottweg.com

**Fluidyne Corporation**  
Cedar Falls, IA  
319-266-9967 • Fax: 319-277-6034  
fluidyne@fluidynecorp.com  
www.fluidynecorp.com



**Does primary treatment have to  
take up so much space?**

Traditional primary wastewater treatment has required large, energy-hungry settling tanks, but this need not be the case. Technological advancements now mean that the same capability can be achieved in a much smaller footprint and at a much lower energy requirement – freeing up space and cutting costs.

**Challenge convention:** visit [hydro-int.com/microscreen](http://hydro-int.com/microscreen) or search **hydro microscreen** online.





**GEA Group**  
Northvale, NJ  
800-722-6622 • 201-767-3900 • Fax: 201-767-3901  
info.wsus@gea.com  
www.gea.com

**Greener Planet Systems**  
Monroe, IA  
888-669-1787 • 517-719-2580  
brianm@greenerplanetsystems.com  
www.greenerplanetsystems.com

**Gryphon Environmental**  
Owensboro, KY  
270-485-2680  
info@2gryphon.com  
www.2gryphon.com

**Hydra-Tech Pumps**  
Nesquehoning, PA  
570-645-3779 • Fax: 570-645-4061  
htpump@hydra-tech.com  
www.hydra-tech.com

**In-Pipe Technology**  
Wood Dale, IL  
888-325-5033 • 630-509-2488 • Fax: 630-509-2490  
jwilliams@in-pipe.com  
www.in-pipe.com



**Kifco, Inc.**  
Havana, IL  
800-452-7017 • 309-543-4425 • Fax: 309-543-4945  
sales@kifco.com  
www.kifco.com

Ad on page 116



**Komline-Sanderson**  
Peapack, NJ  
800-225-5457 • 908-234-1000 • Fax: 908-234-9487  
info@komline.com  
www.komline.com

Ad on page 69

**Kuhn North America, Inc.**

Brodhead, WI  
608-897-2131 • Fax: 608-897-2561  
chris.searles@kuhn.com  
www.kuhnnorthamerica.com

Ad on page 8

**Ovivo USA, LLC**  
Austin, TX  
512-834-6000 • Fax: 512-834-6039  
info.us@ovivowater.com  
www.ovivowater.com

**Park Process**

Houston, TX  
855-511-7275 • 713-849-7189 • Fax: 713-937-4254  
rcoughman@parkprocess.com  
www.parkprocess.com

Ad on page 116

**Parkson Corporation**  
Ft. Lauderdale, FL  
888-727-5766 • Fax: 954-974-6182  
technology@parkson.com  
www.parkson.com

**Pick Heaters, Inc.**  
West Bend, WI  
262-338-1191 • Fax: 262-338-8489  
info1@pickheaters.com  
www.pickheaters.com

**Schwing Bioset, Inc.**  
Somerset, WI  
844-246-7381 • 715-247-3433 • Fax: 715-247-3438  
marketing@schwingbioset.com  
www.schwingbioset.com

**SRS Crisafulli, Inc.**  
Glendive, MT  
800-442-7867 • 406-365-3393 • Fax: 406-365-8088  
srs@crisafulli.com  
www.crisafullipumps.com

**Trident Processes LLC**  
Sumas, WA  
800-799-3740 • 604-330-2500  
info@tridentprocesses.com  
www.tridentprocesses.com

**USP Technologies (US Peroxide)**  
Atlanta, GA  
877-346-4262 • 404-352-6070 • Fax: 404-352-6077  
info@usp technologies.com  
www.usptechnologies.com

**VaraCorp LLC**  
Wimberley, TX  
800-801-6685 • 512-847-5026 • Fax: 866-611-6703  
info@varacorp.com  
www.varacorp.com

**Blowers**

**Aerzen USA**  
Coatesville, PA  
610-380-0244  
aerzen@aerzenusa.com  
www.aerzen.com/en-us/  
Ad on page 45

**Busch Vacuum Pumps and Systems**  
Virginia Beach, VA  
800-872-7867 • 757-463-7800 • Fax: 757-463-7407  
marketing@buschusa.com  
www.buschusa.com

**Eurus Blower, Inc.**  
Wheaton, IL  
630-221-8282 • Fax: 630-221-1002  
tomh@eurusblower.com  
www.eurusblower.com  
Ad on page 95

**Gardner Denver Inc.**  
Quincy, IL  
866-428-4890 • Fax: 217-221-8780  
www.gardnerdenver.com/gdproducts  
Ad on page 61

**HEMCO Corporation**  
Independence, MO  
800-779-4362 • 816-796-2900 • Fax: 816-796-3333  
info@hemcocorp.com  
www.hemcocorp.com  
Ad on page 117

**Howden Roots**  
Connersville, IN  
800-557-6687 • 765-827-9200 • Fax: 765-827-9317  
connersville.customer@howden.com  
www.howdenroots.com

**KCH Engineered Services**  
Forest City, NC  
828-245-9836  
khankinson@kchservices.com  
www.kchservices.com

**Milwaukee Rubber Products, Inc.**  
Menomonee Falls, WI  
800-325-3730 • 262-781-7888 • Fax: 262-781-1742  
sales@milwaukeerubber.com  
www.milwaukeerubber.com

**Proco Products, Inc.**  
Stockton, CA  
800-344-3246 • 209-943-6088 • Fax: 209-943-0242  
sales@procoproducts.com  
www.procoproducts.com

**Red Valve Co. / Tideflex Technologies**  
Carnegie, PA  
412-279-0044 • Fax: 412-279-7878  
sales@redvalve.com  
www.redvalve.com  
Ad on page 35

**Robuschi USA**  
Quincy, IL  
866-428-4890 • Fax: 217-221-8780  
www.gardnerdenver.com/robuschi/  
Ad on page 119

**Sierra Environmental Technologies, LLC**  
Wildwood, MO  
636-273-5189 • Fax: 636-273-4509  
dnokes@setodorcontrol.com  
www.setodorcontrol.com

**SULZER**  
Sulzer Pumps Solutions Inc.  
Meriden, CT  
800-525-7790 • 203-238-2700 • Fax: 203-238-0738  
info.abs.usa@sulzer.com  
www.sulzer.com

**Tuthill**  
Tuthill Vacuum & Blower Systems  
Springfield, MO  
800-825-6937 • 417-865-8715 • Fax: 417-865-2950  
vacuum@tuthill.com  
www.tuthillvacuumblower.com

**Wastewater Depot, LLC**  
Batavia, OH  
513-732-0129 • Fax: 513-735-1485  
info@wastewaterdepot.com  
www.wastewaterdepot.com

**Boilers**

**Chromalox**  
Pittsburgh, PA  
800-443-2640 • 412-967-3800 • Fax: 412-967-5148  
sales@chromalox.com  
www.chromalox.com

**JDV Equipment Corporation**  
Dover, NJ  
973-366-6556 • Fax: 973-366-3193  
sales@jdvequipment.com  
www.jdvequipment.com  
Ad on page 83

**Parker Boiler Co.**  
Los Angeles, CA  
323-727-9800 • Fax: 323-722-2848  
mleeming@parkerboiler.com  
www.parkerboiler.com

**Walker Process Equipment, A Div. of McNish Corp.**  
Aurora, IL  
800-992-5537 • 630-892-7921 • Fax: 630-892-7951  
walker.process@walker-process.com  
www.walker-process.com  
Ad on page 87

**Buildings/Structures**

**ClearSpan Fabric Structures**  
South Windsor, CT  
866-643-1010  
trussingquiry@clearspan.com  
www.clearspan.com  
Ad on page 77

**CST Industries, Inc.**  
Kansas City, MT  
913-621-3700  
sales@cstindustries.com  
www.cstindustries.com

**Rhino Linings Corporation**  
San Deigo, CA  
800-747-6966 • 858-450-0441 • Fax: 858-450-6881  
sales@rhinolining.com  
www.rhinolining.com  
Ad on page 19



**CCTV Pipe Crawlers**

**Deep Trekker Inc.**

Kitchener, ON  
Canada  
519-342-3177  
sales@deeptrekker.com  
www.deeptrekker.com  
Ad on page 93

**Centrifuges/Separators**

**Alfa Laval Inc.**

Richmond, VA  
866-253-2528  
customerservice.usa@alfalaval.com  
www.alfalaval.us

**Amiad USA**

Mooreville, NC  
704-662-3133 • Fax: 704-662-3155  
infousa@amiad.com  
www.amiadusa.com

**Aqseptence Group Inc.**

New Brighton, MN  
800-833-9473 • 651-636-3900 • Fax: 651-638-3171  
matthew.bentley@aqseptence.com  
www.johnsonscreens.com

**BCR Environmental Corporation**

Jacksonville, FL  
904-819-9170 • Fax: 904-998-3828  
marketing@bcrenv.com  
www.bcrenv.com

**Centrisys Corporation**

Kenosha, WI  
262-654-6006 • Fax: 262-764-8705  
info@centrisys.us  
www.centrisys.com  
Ad on page 81



**DRYCAKE**  
Vancouver, BC  
Canada  
877-379-2253 • 604-535-2238  
sales@drycake.com  
www.drycake.com



**Flottweg Separation Technology, Inc.**  
Independence, KY  
859-448-2331 • Fax: 859-448-2333  
sales@flottweg.net  
www.flottweg.com



**GEA Group**  
Northvale, NJ  
800-722-6622 • 201-767-3900 • Fax: 201-767-3901  
info.wsus@gea.com  
www.gea.com

**Robuschi USA**

Quincy, IL  
866-428-4890 • Fax: 217-221-8780  
www.gardnerdenver.com/robuschi/  
Ad on page 119

**Smith & Loveless, Inc.**

Lenexa, KS  
800-898-9122 • 913-888-5201  
answers@smithandloveless.com  
www.smithandloveless.com

**Trident Processes LLC**

Sumas, WA  
800-799-3740 • 604-330-2500  
info@tridentprocesses.com  
www.tridentprocesses.com

**Chain**

**Duramax Cast Stainless Steel Chain & Equipment Products**

Pewaukee, WI  
800-691-0998 • 262-691-0998 • Fax: 262-691-0992  
www.duramaxchain.com

**Chemical/Polymer Feed Equipment**

**AdEdge Water Technologies, LLC**

Duluth, GA  
866-823-3343 • 678-835-0052 • Fax: 678-835-0057  
sales@adedgetechnologies.com  
www.adedgetech.com  
Ad on page 25

**AllChem Performance Products**

Gainesville, FL  
352-333-7327 • Fax: 866-343-1216  
horizon@allchem.com  
www.horizonwater.com



**Blue-White Industries**

Huntington Beach, CA  
714-893-8529 • Fax: 714-894-9492  
sales@blue-white.com  
www.blue-white.com  
Ad on page 2

**Boerger, LLC**

Chanhassen, MN  
612-435-7300 • Fax: 612-435-7301  
america@boerger.com  
www.boerger.com  
Ad on page 55



**ACE<sup>17</sup>**  
ANNUAL CONFERENCE & EXPOSITION

JUNE 11-14 | PHILADELPHIA, PA

**REGISTER TODAY**

Select the Field Operator Full-Conference registration and stay for the entire conference at a discounted rate!

[www.awwa.org/ACE17](http://www.awwa.org/ACE17)

**DRINKING · REUSE · WASTEWATER · STORMWATER**



**DRYCAKE**  
Vancouver, BC  
Canada  
877-379-2253 • 604-535-2238  
sales@drycake.com  
www.drycake.com

**Eagle Microsystems, Inc.**  
Pottstown, PA  
800-780-8636 • 610-323-2250 • Fax: 610-323-0114  
info@eaglemicrosystems.com  
www.eaglemicrosystems.com

**Force Flow**  
Concord, CA  
800-893-6723 • 925-686-6700 • Fax: 925-686-6713  
info@forceflow.com  
www.forceflow.com  
**Ad on page 89**

**Hawkins Water Treatment Group**  
Roseville, MN  
800-328-5460 • 612-331-6910 • Fax: 612-331-5304  
laura.eilek@hawkinsinc.com  
www.hawkinsinc.com

**Lutz-JESCO America Corp.**  
Rochester, NY  
800-554-2762 • 585-426-0990 • Fax: 585-426-4025  
mail@jescoamerica.com  
www.lutzjescoamerica.com

**Park Process**  
Houston, TX  
855-511-7275 • 713-849-7189 • Fax: 713-937-4254  
rcaughman@parkprocess.com  
www.parkprocess.com  
**Ad on page 116**

**Peabody Engineering and Supply Inc.**  
Corona, CA  
877-734-3759 • Fax: 951-734-4111  
sales@4peabody.com  
www.4peabody.com

**Prominent Fluid Controls, Inc.**  
Pittsburgh, PA  
412-787-2484 • Fax: 412-787-0704  
sales@prominent.us  
www.prominent.us

**Pulsafeeder, Inc.**  
Punta Gorda, FL  
800-333-6677 • 941-575-3800 • Fax: 941-575-4085  
ppgspotech@idexcorp.com  
www.pulsatron.com

**Red Valve Co. / Tideflex Technologies**  
Carnegie, PA  
412-279-0044 • Fax: 412-279-7878  
sales@redvalve.com  
www.redvalve.com  
**Ad on page 35**

**SAF-T-FLO Chemical Injection**  
Anaheim, CA  
800-957-2383 • 714-632-3013 • Fax: 714-632-3350  
info@safflo.com  
www.safflo.com  
**Ad on page 47**

**SEEPEx Inc.**  
Enon, OH  
937-864-7150 • Fax: 937-864-7157  
sales.us@seepex.com  
www.seepex.com  
**Ad on page 71**

**USP Technologies (US Peroxide)**  
Atlanta, GA  
877-346-4262 • 404-352-6070 • Fax: 404-352-6077  
info@uspstechnologies.com  
www.uspstechnologies.com

**Watson-Marlow Fluid Technology Group**  
Wilmington, MA  
800-282-8823 • 978-658-6168 • Fax: 978-658-0041  
support@wmpg.us  
www.watson-marlow.com  
**Ad on page 53**

## Chemicals

**AGC Chemicals Americas, Inc.**  
Exton, PA  
800-424-7833 • 610-423-4300 • Fax: 610-423-4301  
www.agcchem.com

**AllChem Performance Products**  
Gainesville, FL  
352-333-7327 • Fax: 866-343-1216  
horizon@allchem.com  
www.horizonwater.com

**Bionetix International**  
Ste-Anne-de-Bellevue, QC  
Canada  
514-457-2914 • Fax: 514-457-3589  
info@bionetix.ca  
www.bionetix-international.com

**Byo-Gon, Inc.**  
Charleston, SC  
888-796-4661 • 843-822-3415 • Fax: 843-606-6318  
info@byogon.com  
www.byogon.com  
**Ad on page 117**

**CEI - Carbon Enterprises Inc.**  
Circleville, OH  
800-344-5770 • Fax: 888-204-9656  
info@ceicompanies.com  
www.ceifiltration.com

**CHEMetrics, Inc.**  
Midland, VA  
800-356-3072 • 540-788-9026 • Fax: 540-788-4856  
sales@chemetrics.com  
www.chemetrics.com

**Electrolytic Technologies LLC**  
North Miami Beach, FL  
305-655-2755 • Fax: 305-655-2669  
info@electrolytictech.com  
www.electrolytictech.com  
**Ad on page 116**

**Enterprise Specialty Products**  
Laurens, SC  
864-984-7700 • Fax: 864-984-2241  
www.enterprisesp.com

**Hach**  
Loveland, CO  
800-227-4224 • 970-669-3050  
orders@hach.com  
www.hach.com  
**Ad on page 5**

**Hawkins Water Treatment Group**  
Roseville, MN  
800-328-5460 • 612-331-6910 • Fax: 612-331-5304  
laura.eilek@hawkinsinc.com  
www.hawkinsinc.com

**Hydrite Chemical Co.**  
Brookfield, WI  
262-792-1450  
marketing@hydrite.com  
www.hydrite.com

**International Products Corporation**  
Burlington, NJ  
609-386-8770 • Fax: 609-386-8438  
mkt@ipcol.com  
www.ipcol.com

**LANXESS / International Dioxide, Inc.**  
North Kingstown, RI  
401-295-8800 • Fax: 401-295-7108  
adox@lanxess.com  
www.lanxess.com

**Lutz-JESCO America Corp.**  
Rochester, NY  
800-554-2762 • 585-426-0990 • Fax: 585-426-4025  
mail@jescoamerica.com  
www.lutzjescoamerica.com

**OMI Industries**  
Long Grove, IL  
800-662-6367 • Fax: 847-304-0989  
www.omi-industries.com

**Rhino Linings Corporation**  
San Diego, CA  
800-747-6966 • 858-450-0441 • Fax: 858-450-6881  
sales@rhinolining.com  
www.rhinolining.com  
**Ad on page 19**



**Ruthman Companies**  
Cincinnati, OH  
859-824-3100 • Fax: 859-824-7248  
www.gusher.com/contact-us  
www.ruthmancompanies.com/ruthman-companies  
**Ad on page 37**

**USP Technologies (US Peroxide)**  
Atlanta, GA  
877-346-4262 • 404-352-6070 • Fax: 404-352-6077  
info@uspstechnologies.com  
www.uspstechnologies.com

**Wako Chemicals USA, Inc.**  
Richmond, VA  
877-714-1920 • 804-714-1920 • Fax: 804-271-7791  
www.wakousa.com

## Chlorination/Dechlorination Equipment

**AllChem Performance Products**  
Gainesville, FL  
352-333-7327 • Fax: 866-343-1216  
horizon@allchem.com  
www.horizonwater.com

**ASA Analytics**  
Waukesha, WI  
262-717-9500 • Fax: 262-717-9530  
info@chemscan.com  
www.asaanalytics.com

## Blue-White Industries, Ltd.

**Blue-White Industries**  
Huntington Beach, CA  
714-893-8529 • Fax: 714-894-9492  
sales@blue-white.com  
www.blue-white.com  
**Ad on page 2**

**Eagle Microsystems, Inc.**  
Pottstown, PA  
800-780-8636 • 610-323-2250 • Fax: 610-323-0114  
info@eaglemicrosystems.com  
www.eaglemicrosystems.com

**Force Flow**  
Concord, CA  
800-893-6723 • 925-686-6700 • Fax: 925-686-6713  
info@forceflow.com  
www.forceflow.com  
**Ad on page 89**

**Hach**  
Loveland, CO  
800-227-4224 • 970-669-3050  
orders@hach.com  
www.hach.com  
**Ad on page 5**

**Harwil Corp.**  
Oxnard, CA  
805-988-6800 • Fax: 805-988-6804  
sales@harwil.com  
www.harwil.com

**Hawkins Water Treatment Group**  
Roseville, MN  
800-328-5460 • 612-331-6910 • Fax: 612-331-5304  
laura.eilek@hawkinsinc.com  
www.hawkinsinc.com

**Lutz-JESCO America Corp.**  
Rochester, NY  
800-554-2762 • 585-426-0990 • Fax: 585-426-4025  
mail@jescoamerica.com  
www.lutzjescoamerica.com

**NEFCO Systems, Inc.**  
Palm Beach Gardens, FL  
561-775-9303 • Fax: 561-775-6043  
sales@nefco.us  
www.nefco.us

**Prominent Fluid Controls, Inc.**  
Pittsburgh, PA  
412-787-2484 • Fax: 412-787-0704  
sales@prominent.us  
www.prominent.us

**Pulsafeeder, Inc.**  
Punta Gorda, FL  
800-333-6677 • 941-575-3800 • Fax: 941-575-4085  
ppgspotech@idexcorp.com  
www.pulsatron.com

**SAF-T-FLO Chemical Injection**  
Anaheim, CA  
800-957-2383 • 714-632-3013 • Fax: 714-632-3350  
info@safflo.com  
www.safflo.com  
**Ad on page 47**

**Sensorex**  
Garden Grove, CA  
800-835-4344 • 714-895-4344  
sales@sensorex.com  
www.sensorex.com



**Wastewater Depot, LLC**  
Batavia, OH  
513-732-0129 • Fax: 513-735-1485  
info@wastewaterdepot.com  
www.wastewaterdepot.com

**Watson-Marlow Fluid Technology Group**  
Wilmington, MA  
800-282-8823 • 978-658-6168 • Fax: 978-658-0041  
support@wmpg.us  
www.watson-marlow.com  
**Ad on page 53**

**Chlorine Emergency Shutoff Systems**

**HALOGEN VALVE SYSTEMS, INC.**  
Your Partner in Safety  
**Halogen Valve Systems, Inc.**  
Irvine, CA  
949-261-5030 • Fax: 949-261-5033  
info@halogenvulve.com  
www.halogenvulve.com

**Clarifier Drives**

**Rebuild-It Service Group, LLC**  
Midvale, UT  
888-709-5676 • Fax: 385-355-6989  
treyburn@rebuild-it.com  
www.rebuild-it.com

**WesTech Engineering**  
Salt Lake City, UT  
801-265-1000 • Fax: 801-265-1080  
info@westech-inc.com  
www.westech-inc.com

**Clarifier/Digester/Tank Cleaning**



**Ford Hall Company, Inc.**  
Richmond, KY  
859-624-1077 • Fax: 859-624-3320  
sperry@fordhall.com  
www.weir-wolf.com  
**Ad on page 79**

**GillTrading.com, Inc./WeirWasher, ACS**  
Beaverton, OR  
866-447-2496 • 503-628-0197 • Fax: 503-646-9293  
brentgill@gilltrading.com  
www.gilltrading.com

**JPCI Services**  
Mesa, AZ  
480-986-1212  
info@jpciservices.com  
www.jpciservices.com

**Nasco Whirl-Pak**  
Fort Atkinson, WI  
800-558-9595 • 920-568-5578 • Fax: 920-568-5778  
info@enasco.com  
www.enasco.com/whirlpak  
**Ad on page 117**

**NEFCO Systems, Inc.**  
Palm Beach Gardens, FL  
561-775-9303 • Fax: 561-775-6043  
sales@neco.us  
www.neco.us

**Permastore**  
Suffolk  
England  
011 44 1379870723  
sales@permastore.com  
www.permastore.com

**U.S. Submergent Technologies LLC**  
Sarasota, FL  
844-765-7866 • 941-444-1440 • Fax: 941-219-3080  
info@ussubmergent.com  
www.ussubmergent.com

**Clarifiers**

**AMWELL, A Div. of McNish Corp.**  
Aurora, IL  
630-898-6900 • Fax: 630-898-1647  
phaizman@amwell-inc.com  
www.amwell-inc.com

**Aqseptence Group Inc.**  
New Brighton, MN  
800-833-9473 • 651-636-3900 • Fax: 651-638-3171  
matthew.bentley@aqseptence.com  
www.johnsonscreeens.com

**Bio-Microbics, Inc.**  
Shawnee, KS  
800-753-3278 • 913-422-0707 • Fax: 913-422-0808  
sales@biomicrobics.com  
www.biomicrobics.com

**CST Industries, Inc.**  
Kansas City, MT  
913-621-3700  
sales@cstindustries.com  
www.cstindustries.com

**DURAMAX**  
**Duramax Cast Stainless Steel Chain & Equipment Products**  
Pewaukee, WI  
800-691-0998 • 262-691-0998 • Fax: 262-691-0992  
www.duramaxchain.com

**Evoqua Water Technologies LLC**  
Warrendale, PA  
800-466-7873 • 724-772-0044  
municipalmarketing@evoqua.com  
www.evoqua.com

**Fibergate Composite Structures**  
Dallas, TX  
800-527-4043 • 972-250-1633 • Fax: 972-250-1530  
info@fibergate.com  
www.fibergate.com



Fast, accurate solids results for **\$10K?** less than

**That's SMART!**

**SMART 6™**  
Microwave Moisture/Solids Analyzer

- Results in as little as 2 minutes
- Maintain high solids to reduce incineration and transportation costs
- Rapidly calculate Total Suspended Solids (TSS), Volatile Suspended Solids (VSS) & Volatile Solids (VS)
- Ensure regulatory compliance for discharge
- Optimize polymer usage
- Pre-programmed methods for cake, feed, and polymers

Contact CEM today for a free demonstration.  
(800) 726-3331 • info@cem.com



**Garland Manufacturing Company**

Saco, ME  
800-727-1900 • 207-283-3693 • Fax: 207-283-4834  
wastewater@garlandmfg.com  
www.garlandmfg.com/plastics/wastewater.html

Ad on page 89



**GEA Group**  
Northvale, NJ  
800-722-6622 • 201-767-3900 • Fax: 201-767-3901  
info.wsus@gea.com  
www.gea.com



**GillTrading.com, Inc./WeirWasher, ACS**  
Beaverton, OR  
866-447-2496 • 503-628-0197 • Fax: 503-646-9293  
brentgill@gilltrading.com  
www.gilltrading.com

**Headworks International, Inc.**  
Houston, TX  
713-647-6667 • Fax: 713-647-0999  
hw@headworksintl.com  
www.headworksintl.com



Cleaner Water for a Brighter Future®  
**Lakeside Equipment Corporation**  
Bartlett, IL  
630-837-5640 • Fax: 630-837-5647  
sales@lakeside-equipment.com  
www.lakeside-equipment.com

Ad on page 3

**Nasco Whirl-Pak**

Fort Atkinson, WI  
800-558-9595 • 920-568-5578 • Fax: 920-568-5778  
info@enasco.com  
www.enasco.com/whirlpak

Ad on page 117

**NEFCO Systems, Inc.**  
Palm Beach Gardens, FL  
561-775-9303 • Fax: 561-775-6043  
sales@nefco.us  
www.nefco.us



**OVIVO USA, LLC**  
Austin, TX  
512-834-6000 • Fax: 512-834-6039  
info.us@ovivowater.com  
www.ovivowater.com

**PermaStore**  
Suffolk  
England  
011 44 1379870723  
sales@permastore.com  
www.permastore.com

**PolyScience**  
Niles, IL  
800-229-7569 • 847-647-0611 • Fax: 847-647-1155  
sales@polyscience.com  
www.polyscience.com

**Rebuild-It Service Group, LLC**  
Midvale, UT  
888-709-5676 • Fax: 385-355-6989  
treburn@rebuild-it.com  
www.rebuild-it.com

**Smith & Loveless, Inc.**  
Lenexa, KS  
800-898-9122 • 913-888-5201  
answers@smithandloveless.com  
www.smithandloveless.com

**Superior Tank Co., Inc.**  
Rancho Cucamonga, CA  
877-974-4438 • 909-912-0580 • Fax: 909-912-0585  
marketing@superiortank.com  
www.superiortank.com  
Ad on page 75

**Walker Process Equipment, A Div. of McNish Corp.**  
Aurora, IL  
800-992-5537 • 630-892-7921 • Fax: 630-892-7951  
walker.process@walker-process.com  
www.walker-process.com

Ad on page 87

**Wastewater Depot, LLC**  
Batavia, OH  
513-732-0129 • Fax: 513-735-1485  
info@wastewaterdepot.com  
www.wastewaterdepot.com



**Westech Engineering**  
Salt Lake City, UT  
801-265-1000 • Fax: 801-265-1080  
info@westech-inc.com  
www.westech-inc.com

**Cleaners**

**International Products Corporation**  
Burlington, NJ  
609-386-8770 • Fax: 609-386-8438  
mki@ipcol.com  
www.ipcol.com

**Coagulants/Flocculants/Flocculators**

**Aqseptence Group Inc.**  
New Brighton, MN  
800-833-9473 • 651-636-3900 • Fax: 651-638-3171  
matthew.bentley@aqseptence.com  
www.johnsonscreens.com

**Bionetix International**  
Ste-Anne-de-Bellevue, QC  
Canada  
514-457-2914 • Fax: 514-457-3589  
info@bionetix.ca  
www.bionetix-international.com

**Boerger, LLC**  
Chanhassen, MN  
612-435-7300 • Fax: 612-435-7301  
america@boerger.com  
www.boerger.com  
Ad on page 55

**Duramax Cast Stainless Steel Chain & Equipment Products**  
Pewaukee, WI  
800-691-0998 • 262-691-0998 • Fax: 262-691-0992  
www.duramaxchain.com

**Hawkins Water Treatment Group**  
Roseville, MN  
800-328-5460 • 612-331-6910 • Fax: 612-331-5304  
laura.eilek@hawkinsinc.com  
www.hawkinsinc.com

**Hydrite Chemical Co.**  
Brookfield, WI  
262-792-1450  
marketing@hydrite.com  
www.hydrite.com

**LANXESS / International Dioxide, Inc.**  
North Kingstown, RI  
401-295-8800 • Fax: 401-295-7108  
adox@lanxess.com  
www.lanxess.com

**Trident Processes LLC**  
Sumas, WA  
800-799-3740 • 604-330-2500  
info@tridentprocesses.com  
www.tridentprocesses.com

**USALCO, LLC**  
Baltimore, MD  
800-882-3883 • 410-918-2230  
ctesone@usalco.com  
www.usalco.com  
Ad on page 81

**Coatings/Linings/Sealants**

**Rhino Linings Corporation**  
San Diego, CA  
800-747-6966 • 858-450-0441 • Fax: 858-450-6881  
sales@rhinolinings.com  
www.rhinolinings.com  
Ad on page 19

**Communication Equipment**

**Phoenix Contact**  
Middletown, PA  
800-888-7388 • 717-944-1300  
info@phoenixcon.com  
www.phoenixcontact.com/usa\_home

**ProComSol, Ltd**  
Lakewood, OH  
877-221-1551 • 216-221-1550 • Fax: 216-221-1554  
sales@procomsol.com  
www.procomsol.com  
Ad on page 85

**Weidmüller**  
Richmond, VA  
800-849-9343 • Fax: 804-379-2593  
info@weidmuller.com  
www.weidmuller.com

**Composting Equipment/Systems**

**BCR Environmental Corporation**  
Jacksonville, FL  
904-819-9170 • Fax: 904-998-3828  
marketing@bcrenv.com  
www.bcrenv.com

**BDP Industries**  
Greenwich, NY  
518-695-6851 • Fax: 518-695-5417  
dan@bdpindustries.com  
www.bdpindustries.com  
Ad on page 73

**Brown Bear Corporation**  
Corning, IA  
641-322-4220 • Fax: 641-322-3527  
sales@brownbearcorp.com  
www.brownbearcorp.com

**GORE® Cover**  
Elkton, MD  
410-506-5041  
bfuchs@wlgore.com  
www.gorecover.com

**Kuhn North America, Inc.**  
Brodhead, WI  
608-897-2131 • Fax: 608-897-2561  
chris.searles@kuhn.com  
www.kuhnnorthamerica.com  
Ad on page 8

**Rotomix, LLC**  
Dodge City, KS  
620-225-1142 • Fax: 620-225-6370  
info@rotomix.com  
www.rotomix.com  
Ad on page 93

**Compressors**

**Aerzen USA**  
Coatesville, PA  
610-380-0244  
aerzen@aerzenusa.com  
www.aerzen.com/en-us/  
Ad on page 45

**Anue Water Technologies, Inc.**  
Oceanside, CA  
760-727-2683  
info@anuewater.com  
www.anuewater.com



**Busch Vacuum Pumps and Systems**  
Virginia Beach, VA  
800-872-7867 • 757-463-7800 • Fax: 757-463-7407  
marketing@buschusa.com  
www.buschusa.com

**Gardner Denver Inc.**  
Quincy, IL  
866-428-4890 • Fax: 217-221-8780  
www.gardnerdenver.com/gdproducts

Ad on page 61

**Howden Roots**  
Connersville, IN  
800-557-6687 • 765-827-9200 • Fax: 765-827-9317  
connersville.customercare@howden.com  
www.howdenroots.com

**Sulzer Pumps Solutions Inc.**  
Meriden, CT  
800-525-7790 • 203-238-2700 • Fax: 203-238-0738  
info.abs.usa@sulzer.com  
www.sulzer.com

**Confined Space Entry**

**AmTech Tank Lining & Repair**  
Plymouth, NH  
888-839-0373 • Fax: 603-947-9500  
info@amtechtanklining.com  
www.amtechtanklining.com

Ad on page 91

**ENMET**  
Ann Arbor, MI  
800-521-2978 • 734-761-1270 • Fax: 734-761-3220  
info@enmet.com  
www.enmet.com

**INDUSTRIAL SCIENTIFIC**

**Industrial Scientific**  
Pittsburgh, PA  
412-788-4353 • Fax: 412-788-8353  
info@indsci.com  
www.indsci.com

**Milwaukee Rubber Products, Inc.**  
Menomonee Falls, WI  
800-325-3730 • 262-781-7888 • Fax: 262-781-1742  
sales@milwaukeeerubber.com  
www.milwaukeeerubber.com

**RKI Instruments, Inc.**  
Union City, CA  
800-754-5165 • 510-441-5656 • Fax: 510-441-5650  
orders@rkiinstruments.com  
www.rkiinstruments.com

**Consulting/Engineering/Design Services**

**Activated Carbon Services - PACS**  
Coraopolis, PA  
800-367-2587 • 724-457-6576  
henry@pacslabs.com  
www.pacslabs.com

**AdEdge Water Technologies, LLC**  
Duluth, GA  
866-823-3343 • 678-835-0052 • Fax: 678-835-0057  
sales@adedgetechnologies.com  
www.adedgetech.com

Ad on page 25

**Aqua Operations, Inc.**  
Bakersfield, CA  
888-746-6535 • 661-331-1181 • Fax: 661-833-1861  
childerbrand@aquaoperations.com  
www.aquaoperations.com

**Environmental Coatings LLC**  
Mesa, AZ  
480-984-7608  
info@sewershield.com  
www.sewershield.com

**F & V Operations and Resource Management**  
Grand Rapids, MI  
888-773-8806 • 616-588-2900 • Fax: 616-977-1005  
bselover@fv-operations.com  
www.fv-operations.com

**Gardner Denver Inc.**  
Quincy, IL  
866-428-4890 • Fax: 217-221-8780  
www.gardnerdenver.com/gdproducts

Ad on page 61

**Geomembrane Technologies Inc.**  
Fredericton, NB  
Canada  
855-484-4630 • 506-452-7304 • Fax: 506-452-6625  
covers@gticovers.com  
www.gticovers.com

**Howden Roots**  
Connersville, IN  
800-557-6687 • 765-827-9200 • Fax: 765-827-9317  
connersville.customercare@howden.com  
www.howdenroots.com

**Hydromantis Environmental Software Solutions, Inc.**  
Hamilton, ON  
Canada  
905-522-0012 • Fax: 905-522-0031  
info@hydromantis.com  
www.hydromantis.com

**Lutz-JESCO America Corp.**  
Rochester, NY  
800-554-2762 • 585-426-0990 • Fax: 585-426-4025  
mail@jescoamerica.com  
www.lutzjescoamerica.com

**McCrometer Inc.**  
Hemet, CA  
800-220-2279 • 951-652-6811 • Fax: 951-652-3078  
customerservice@mccrometer.com  
www.mccrometer.com

**OMI Industries**  
Long Grove, IL  
800-662-6367 • Fax: 847-304-0989  
www.omi-industries.com

**Philadelphia Gear - A Timken Brand**  
King of Prussia, PA  
800-766-5120 • 610-265-3000 • Fax: 610-337-5637  
info@philgear.com  
www.philgear.com

**Wastewater Treatment and Sludge Management Solutions from Komline-Sanderson**



**Pump. Thicken. Dewater. Dry.**

**Paddle Dryer**

- indirectly heated
- produce Class A product
- high efficiency



**Belt Filter Press**

- sludge dewatering
- high cake solids
- low polymer cost

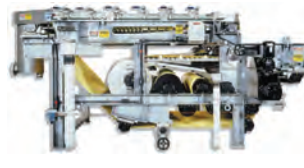

**Gravity Belt Thickener**

- sludge thickening
- high rates
- low polymer cost



**Dissolved Air Flotation**

- sludge thickening
- wastewater clarification
- high float solids



**Rotary Vacuum Filter**

- sludge dewatering
- wastewater clarification
- continuous operation



**Plunger Pump**

- sludge transfer
- positive displacement
- high suction lift



FREE INFO - SEE ADVERTISER INDEX



**Ruthman Companies**

Cincinnati, OH  
859-824-3100 • Fax: 859-824-7248  
www.gusher.com/contact-us  
www.ruthmancompanies.com/ruthman-companies  
**Ad on page 37**

**U.S. Water Services Corporation**

New Port Richey, FL  
866-753-8292 • 515-269-2336 • Fax: 727-848-7701  
info@uswatercorp.net  
www.uswatercorp.com

**Control/Electrical Panels**

**Aerzen USA**

Coatesville, PA  
610-380-0244  
aerzen@aerzenusa.com  
www.aerzen.com/en-us/  
**Ad on page 45**

**ElectroSwitch Corporation**

Weymouth, MA  
781-335-5200  
info@electroswitch.com  
www.electroswitch.com

**Philadelphia Gear - A Timken Brand**

King of Prussia, PA  
800-766-5120 • 610-265-3000 • Fax: 610-337-5637  
info@philagear.com  
www.philagear.com



**PRIMEX**

Detroit Lakes, MN  
888-342-5753 • 218-847-1317 • Fax: 218-847-4617  
info@primexcontrols.com  
www.primexcontrols.com

**Ronk Electrical**

Nokomis, IL  
800-221-7665 • 217-563-8333 • Fax: 217-563-8336  
sales@ronkelectrical.com  
www.ronkelectrical.com  
**Ad on page 116**

**Sulzer Pumps Solutions Inc.**

Meriden, CT  
800-525-7790 • 203-238-2700 • Fax: 203-238-0738  
info.abs.usa@sulzer.com  
www.sulzer.com

**Trihedral Engineering Limited**

Bedford, NS  
Canada  
800-463-2783 • 902-835-1575 • Fax: 902-835-0369  
pcooke@trihedral.com  
www.trihedral.com

**WEG Electric Corp**

Duluth, GA  
800-275-4934  
info-us@weg.net  
www.weg.net/us

**Controllers**

**Chromalox**

Pittsburgh, PA  
800-443-2640 • 412-967-3800 • Fax: 412-967-5148  
sales@chromalox.com  
www.chromalox.com

**Cla-Val**

Costa Mesa, CA  
800-942-6326 • 949-722-4800 • Fax: 949-574-5703  
info@cla-val.com  
www.cla-val.com

**Data Flow Systems, Inc.**

Melbourne, FL  
321-259-5009 • Fax: 321-259-4006  
info@dataflowsys.com  
www.dataflowsys.com

**Eagle Microsystems, Inc.**

Pottstown, PA  
800-780-8636 • 610-323-2250 • Fax: 610-323-0114  
info@eaglemicrosystems.com  
www.eaglemicrosystems.com

**Emerson Automation Solutions**

Pittsburgh, PA  
800-445-9723 • 412-963-4000  
powerwater@emerson.com  
www.emerson.com/water

**Force Flow**

Concord, CA  
800-893-6723 • 925-686-6700 • Fax: 925-686-6713  
info@forceflow.com  
www.forceflow.com  
**Ad on page 89**

**Hach**

Loveland, CO  
800-227-4224 • 970-669-3050  
orders@hach.com  
www.hach.com  
**Ad on page 5**

**Harwil Corp.**

Oxnard, CA  
805-988-6800 • Fax: 805-988-6804  
sales@harwil.com  
www.harwil.com

**Lutz-JESCO America Corp.**

Rochester, NY  
800-554-2762 • 585-426-0990 • Fax: 585-426-4025  
mail@jescoamerica.com  
www.lutzjescoamerica.com

**Phoenix Contact**

Middletown, PA  
800-888-7388 • 717-944-1300  
info@phoenixcon.com  
www.phoenixcontact.com/usa\_home

**PMC Engineering**

Danbury, CT  
203-792-8686 • Fax: 203-743-2051  
sales@pmc1.com  
www.pmc1.com



**PRIMEX**

Detroit Lakes, MN  
888-342-5753 • 218-847-1317 • Fax: 218-847-4617  
info@primexcontrols.com  
www.primexcontrols.com

**Pulsafeeder, Inc.**

Punta Gorda, FL  
800-333-6677 • 941-575-3800 • Fax: 941-575-4085  
ppgspotech@idexcorp.com  
www.pulsatron.com

**RKI Instruments, Inc.**

Union City, CA  
800-754-5165 • 510-441-5656 • Fax: 510-441-5650  
orders@rkiinstruments.com  
www.rkiinstruments.com

**Sensorex**

Garden Grove, CA  
800-835-4344 • 714-895-4344  
sales@sensorex.com  
www.sensorex.com

**Sierra Instruments, Inc.**

Monterey, CA  
800-866-0200 • 831-373-0200 • Fax: 831-373-4402  
info@sierrainstruments.com  
www.sierrainstruments.com

**Thermal Edge Inc.**

Irving, TX  
888-580-0202 • 972-580-0200 • Fax: 972-580-0202  
thermalinfo@thermal-edge.com  
www.thermal-edge.com

**Van London Co.**

Houston, TX  
800-522-7920 • 832-456-6641 • Fax: 832-456-6642  
anna@vanlondon.com  
www.vanlondon.com

**WEG Electric Corp**

Duluth, GA  
800-275-4934  
info-us@weg.net  
www.weg.net/us

**Conveyors**

**BDP Industries**

Greenwich, NY  
518-695-6851 • Fax: 518-695-5417  
dar@bdpindustries.com  
www.bdpindustries.com  
**Ad on page 73**

**Bright Technologies,  
Division of Sebright Products, Inc.**

Hopkins, MI  
800-253-0532 • 269-793-7183 • Fax: 269-793-4022  
julie@brightbeltpress.com  
www.brightbeltpress.com  
**Ad on page 83**

**Charter Machine Company**

Metuchen, NJ  
732-548-4400  
walterk@chartermachine.com  
www.chartermachine.com

**CleanTek Water Solutions**

Fridley, MN  
866-929-7773  
info@cleantekwater.com  
www.cleantekwater.com



**DRYCAKE**

Vancouver, BC  
Canada  
877-379-2253 • 604-535-2238  
sales@drycake.com  
www.drycake.com

**Enviro-Care Company**

Gurnee, IL  
815-636-8306 • Fax: 847-672-7968  
ecsales@enviro-care.com  
www.enviro-care.com  
**Ad on page 59**

**JDV Equipment Corporation**

Dover, NJ  
973-366-6556 • Fax: 973-366-3193  
sales@jdvequipment.com  
www.jdvequipment.com  
**Ad on page 83**

**Parkson Corporation**

Ft. Lauderdale, FL  
888-727-5766 • Fax: 954-974-6182  
technology@parkson.com  
www.parkson.com

**Philadelphia Gear - A Timken Brand**

King of Prussia, PA  
800-766-5120 • 610-265-3000 • Fax: 610-337-5637  
info@philagear.com  
www.philagear.com

**Schwing Bioset, Inc.**

Somerset, WI  
844-246-7381 • 715-247-3433 • Fax: 715-247-3438  
marketing@schwingbioset.com  
www.schwingbioset.com

**ScreenCo Systems LLC**

Genesee, ID  
208-790-8770  
sales@screenco.com  
www.screenco.com  
**Ad on page 116**

**Smith & Loveless, Inc.**

Lenexa, KS  
800-898-9122 • 913-888-5201  
answers@smithandloveless.com  
www.smithandloveless.com

**Corrosion Instrumentation/  
Protection**

**JPCI Services**

Mesa, AZ  
480-986-1212  
info@jpciservices.com  
www.jpciservices.com



**Covers/Domes**

**ClearSpan Fabric Structures**

South Windsor, CT  
866-643-1010  
trussingquiry@clearspan.com  
www.clearspan.com

Ad on page 77



**CST Industries, Inc.**

Kansas City, MO  
913-621-3700  
sales@cstindustries.com  
www.cstindustries.com

**Environetics, Inc.**

Lockport, IL  
815-838-8331 • Fax: 815-838-8336  
info@environeticsinc.com  
www.environeticsinc.com

**Fibergate Composite Structures**

Dallas, TX  
800-527-4043 • 972-250-1633 • Fax: 972-250-1530  
info@fibergate.com  
www.fibergate.com

**Geomembrane Technologies Inc.**

Fredericton, NB  
Canada  
855-484-4630 • 506-452-7304 • Fax: 506-452-6625  
covers@gticovers.com  
www.gticovers.com

**JDV Equipment Corporation**

Dover, NJ  
973-366-6556 • Fax: 973-366-3193  
sales@jdvequipment.com  
www.jdvequipment.com

Ad on page 83

**NEFCO Systems, Inc.**

Palm Beach Gardens, FL  
561-775-9303 • Fax: 561-775-6043  
sales@nefco.us  
www.nefco.us

**Ovivo USA, LLC**

Austin, TX  
512-834-6000 • Fax: 512-834-6039  
info.us@ovivowater.com  
www.ovivowater.com

**Superior Tank Co., Inc.**

Rancho Cucamonga, CA  
877-974-4438 • 909-912-0580 • Fax: 909-912-0585  
marketing@superiortank.com  
www.superiortank.com

Ad on page 75

**Walker Process Equipment,  
A Div. of McNish Corp.**

Aurora, IL  
800-992-5537 • 630-892-7921 • Fax: 630-892-7951  
walker.process@walker-process.com  
www.walker-process.com

Ad on page 87

**Cranes/Hoists/Winches**

**Philadelphia Gear - A Timken Brand**

King of Prussia, PA  
800-766-5120 • 610-265-3000 • Fax: 610-337-5637  
info@philagear.com  
www.philagear.com

**Data Loggers/Management**

**Data Flow Systems, Inc.**

Melbourne, FL  
321-259-5009 • Fax: 321-259-4006  
info@dataflowsys.com  
www.dataflowsys.com

**Emerson / Rosemount**

Shakopee, MN  
800-854-8257 • 952-906-8888  
liquid.csc@emerson.com  
www.rosemount.com

**Hydromantis Environmental  
Software Solutions, Inc.**

Hamilton, ON  
Canada  
905-522-0012 • Fax: 905-522-0031  
info@hydromantis.com  
www.hydromantis.com

**Keller America Inc.**

Newport News, VA  
877-253-5537 • 757-596-6680 • Fax: 757-596-6659  
sales@kelleramerica.com  
www.kelleramerica.com

Ad on page 7

**McCrometer Inc.**

Hemet, CA  
800-220-2279 • 951-652-6811 • Fax: 951-652-3078  
customerservice@mccrometer.com  
www.mccrometer.com

**PMC Engineering**

Danbury, CT  
203-792-8686 • Fax: 203-743-2051  
sales@pmc1.com  
www.pmc1.com

**RKI Instruments, Inc.**

Union City, CA  
800-754-5165 • 510-441-5656 • Fax: 510-441-5650  
orders@rkiinstruments.com  
www.rkiinstruments.com

**Sensaphone**

Aston, PA  
877-373-2700 • 610-558-2700 • Fax: 610-558-0222  
contact@sensaphone.com  
www.sensaphone.com

**Trihedral Engineering Limited**

Bedford, NS  
Canada  
800-463-2783 • 902-835-1575 • Fax: 902-835-0369  
pcooke@trihedral.com  
www.trihedral.com

**SEEPEx.**  
ALL THINGS FLOW

**UNMATCHED  
STABILITY FOR  
PROCESS CONTROL**

Our ALPHA chemical metering systems – complete with SEEPEx's progressive cavity pumps and controls – offer customers simple plug-and-play installation. They are used in a variety of water treatment applications including disinfection, pH control, coagulation and flocculation. ALPHA minimizes the amount of ancillary equipment, which reduces failure potential, complexity and cost. All wetted materials within the system are corrosion resistant and reliable.

CONVEYING CAPACITY  
**UP TO 250 USGPH**

PRESSURE  
**UP TO 175 PSI**

**ADDITIONAL BENEFITS**

- NSF/ANSI 61 certified Intelligent Metering Pumps with accurate and repeatable flow
- Minimal pulsation and tighter controls
- No vapor lock

Contact us to purchase your chemical metering system.



**Visit Us at  
AWWA ACE  
Booth#3333**

SEEPEx Inc.  
sales.us@seepex.com  
T +1 937 864-7150  
www.seepex.com

## Dealer/Distributor

**Fortiline Waterworks**  
Concord, NC  
844-792-7473 • 704-788-9800  
www.fortiline.com

**Rhino Linings Corporation**  
San Diego, CA  
800-747-6966 • 858-450-0441 • Fax: 858-450-6881  
sales@rhinolinings.com  
www.rhinolinings.com  
**Ad on page 19**

## Decals/Magnets/Signage/Labels/Tags

**Uticom Systems, Inc.**  
Coatesville, PA  
800-548-5321 • 610-857-2655 • Fax: 610-857-2986  
graphics@uticom.net  
www.uticom.net

## Defoamers

**Airmaster Aerator LLC**  
DeRidder, LA  
888-813-3680 • 337-463-6567 • Fax: 337-463-9119  
deanc@airmasteraerator.com  
www.airmasteraerator.com  
**Ad on page 4**

**AQUATURBO SYSTEMS, Inc.**  
Springdale, AR  
479-927-1300 • Fax: 479-927-0700  
ats@aquaturbo.com  
www.aquaturbousa.com

**Bionetix International**  
Ste-Anne-de-Belleveue, QC  
Canada  
514-457-2914 • Fax: 514-457-3589  
info@bionetix.ca  
www.bionetix-international.com

**Enterprise Specialty Products**  
Laurens, SC  
864-984-7700 • Fax: 864-984-2241  
www.enterprisesp.com

**Hawkins Water Treatment Group**  
Roseville, MN  
800-328-5460 • 612-331-6910 • Fax: 612-331-5304  
laura.eilek@hawkinsinc.com  
www.hawkinsinc.com

**Hydrite Chemical Co.**  
Brookfield, WI  
262-792-1450  
marketing@hydrite.com  
www.hydrite.com

**JDV Equipment Corporation**  
Dover, NJ  
973-366-6556 • Fax: 973-366-3193  
sales@jdvequipment.com  
www.jdvequipment.com  
**Ad on page 83**

## Desalination Equipment

**KCH Engineered Systems**  
Forest City, NC  
828-245-9836  
khankinson@kchservices.com  
www.kchservices.com

**SAF-T-FLO Chemical Injection**  
Anaheim, CA  
800-957-2383 • 714-632-3013 • Fax: 714-632-3350  
info@safflo.com  
www.safflo.com  
**Ad on page 47**

**Sulzer Pumps Solutions Inc.**  
Meriden, CT  
800-525-7790 • 203-238-2700 • Fax: 203-238-0738  
info.abs.usa@sulzer.com  
www.sulzer.com

## Detection Equipment

**Eagle Microsystems, Inc.**  
Pottstown, PA  
800-780-8636 • 610-323-2250 • Fax: 610-323-0114  
info@eaglemicrosystems.com  
www.eaglemicrosystems.com

## Diffusers

**American Pleasure Products, Inc.**  
Rose City, MI  
989-685-2697 • Fax: 989-685-8484  
info@aquacycleusa.com  
www.aquacycleusa.com  
**Ad on page 77**

**Aqua-Aerobic Systems, Inc.**  
Loves Park, IL  
800-940-5008 • 815-654-2501 • Fax: 815-654-2508  
solutions@aquaaerobic.com  
www.aquaaerobic.com  
**Ad on page 11**

**Red Valve Co. / Tideflex Technologies**  
Carnegie, PA  
412-279-0044 • Fax: 412-279-7878  
sales@redvalve.com  
www.redvalve.com  
**Ad on page 35**

**RWL Water**  
Golden Valley, MN  
800-879-3677 • 763-746-8400 • Fax: 763-746-8408  
info@rwlwater.com  
www.rwlwater.com

**Wastewater Depot, LLC**  
Batavia, OH  
513-732-0129 • Fax: 513-735-1485  
info@wastewaterdepot.com  
www.wastewaterdepot.com

## Digesters

**Aqua Operations, Inc.**  
Bakersfield, CA  
888-746-6535 • 661-331-1181 • Fax: 661-833-1861  
childerbrand@aquaooperations.com  
www.aquaooperations.com

**CST Industries, Inc.**  
Kansas City, MO  
913-621-3700  
sales@cstindustries.com  
www.cstindustries.com

**F & V Operations and Resource Management**  
Grand Rapids, MI  
888-773-8806 • 616-588-2900 • Fax: 616-977-1005  
bselover@fv-operations.com  
www.fv-operations.com

**JDV Equipment Corporation**  
Dover, NJ  
973-366-6556 • Fax: 973-366-3193  
sales@jdvequipment.com  
www.jdvequipment.com  
**Ad on page 83**

**NEFCO Systems, Inc.**  
Palm Beach Gardens, FL  
561-775-9303 • Fax: 561-775-6043  
sales@nefco.us  
www.nefco.us

**Ovivo USA, LLC**  
Austin, TX  
512-834-6000 • Fax: 512-834-6039  
info.us@ovivowater.com  
www.ovivowater.com

**Permastore**  
Suffolk  
England  
011 44 1379870723  
sales@permastore.com  
www.permastore.com

**RKI Instruments, Inc.**  
Union City, CA  
800-754-5165 • 510-441-5656 • Fax: 510-441-5650  
orders@rkiinstruments.com  
www.rkiinstruments.com

**Shand & Jurs**  
Hillside, IL  
708-236-6000 • Fax: 708-236-6006  
sales@ltechnologies.com  
www.ltechnologies.com  
**Ad on page 29**

**Sierra Environmental Technologies, LLC**  
Wildwood, MO  
636-273-5189 • Fax: 636-273-4509  
dnokes@setodorcontrol.com  
www.setodorcontrol.com

**Smith & Loveless, Inc.**  
Lenexa, KS  
800-898-9122 • 913-888-5201  
answers@smithandloveless.com  
www.smithandloveless.com

**Walker Process Equipment, A Div. of McNish Corp.**  
Aurora, IL  
800-992-5537 • 630-892-7921 • Fax: 630-892-7951  
walker.process@walker-process.com  
www.walker-process.com  
**Ad on page 87**



**Westech Engineering**  
Salt Lake City, UT  
801-265-1000 • Fax: 801-265-1080  
info@westech-inc.com  
www.westech-inc.com

## Disinfection Equipment/Systems

**AllChem Performance Products**  
Gainesville, FL  
352-333-7327 • Fax: 866-343-1216  
horizon@allchem.com  
www.horizonwater.com

**BCR Environmental Corporation**  
Jacksonville, FL  
904-819-9170 • Fax: 904-998-3828  
marketing@bcrenv.com  
www.bcrenv.com

**Bio-Microbics, Inc.**  
Shawnee, KS  
800-753-3278 • 913-422-0707 • Fax: 913-422-0808  
sales@biomicrobics.com  
www.biomicrobics.com

**Electrolytic Technologies LLC**  
North Miami Beach, FL  
305-655-2755 • Fax: 305-655-2669  
info@electrolytictech.com  
www.electrolytictech.com  
**Ad on page 116**

**Evoqua Water Technologies LLC**  
Warrendale, PA  
800-466-7873 • 724-772-0044  
municipalmarketing@evoqua.com  
www.evoqua.com

**Force Flow**  
Concord, CA  
800-893-6723 • 925-686-6700 • Fax: 925-686-6713  
info@forceflow.com  
www.forceflow.com  
**Ad on page 89**

**Halogen Valve Systems, Inc.**  
Irvine, CA  
949-261-5030 • Fax: 949-261-5033  
info@halogenvulve.com  
www.halogenvulve.com

**Hawkins Water Treatment Group**  
Roseville, MN  
800-328-5460 • 612-331-6910 • Fax: 612-331-5304  
laura.eilek@hawkinsinc.com  
www.hawkinsinc.com

**Ovivo USA, LLC**  
Austin, TX  
512-834-6000 • Fax: 512-834-6039  
info.us@ovivowater.com  
www.ovivowater.com

**Pick Heaters, Inc.**  
West Bend, WI  
262-338-1191 • Fax: 262-338-8489  
info1@pickheaters.com  
www.pickheaters.com

**Premier Tech Aqua**  
Riviere-du-Loup, QC  
Canada  
800-632-6356 • 418-867-8883 • Fax: 418-862-6642  
pta@premiertech.com  
www.premiertechaqua.com

**Prominent Fluid Controls, Inc.**  
Pittsburgh, PA  
412-787-2484 • Fax: 412-787-0704  
sales@prominent.us  
www.prominent.us



## SAF-T-FLO Chemical Injection

Anaheim, CA  
800-957-2383 • 714-632-3013 • Fax: 714-632-3350  
info@safflo.com  
www.safflo.com  
**Ad on page 47**

## SALCOR UV

**SALCOR, Inc.**  
Fallbrook, CA  
760-731-0745 • Fax: 760-731-2405  
jscruver@aol.com  
**Ad on page 95**

## SEEPX Inc.

Enon, OH  
937-864-7150 • Fax: 937-864-7157  
sales.us@seepex.com  
www.seepex.com  
**Ad on page 71**

## Smith & Loveless, Inc.

Lenexa, KS  
800-898-9122 • 913-888-5201  
answers@smithandloveless.com  
www.smithandloveless.com

Pure, safe water.



Always.

## UV Pure Technologies, Inc.

Toronto, ON  
Canada  
888-407-9997 • 416-208-9884 • Fax: 416-208-5808  
info@uvpure.com  
www.uvpure.com

## Wastewater Depot, LLC

Batavia, OH  
513-732-0129 • Fax: 513-735-1485  
info@wastewaterdepot.com  
www.wastewaterdepot.com

## Dissolved Air Flotation (DAF)

## Aeration Industries International

Chaska, MN  
800-328-8287 • 952-448-6789 • Fax: 952-448-7293  
aii@aireo2.com  
www.aireo2.com

## Bradley Innovation Group

Indianapolis, IN  
317-726-6615  
sales@big-h2o.com  
www.big-h2o.com

## Headworks International, Inc.

Houston, TX  
713-647-6667 • Fax: 713-647-0999  
hw@headworksintl.com  
www.headworksintl.com

## RWL Water

Golden Valley, MN  
800-879-3677 • 763-746-8400 • Fax: 763-746-8408  
info@rwlwater.com  
www.rwlwater.com

## Trident Processes LLC

Sumas, WA  
800-799-3740 • 604-330-2500  
info@tridentprocesses.com  
www.tridentprocesses.com

## VaraCorp LLC

Wimberley, TX  
800-801-6685 • 512-847-5026 • Fax: 866-611-6703  
info@varacorp.com  
www.varacorp.com

## Westech Engineering

Salt Lake City, UT  
801-265-1000 • Fax: 801-265-1080  
info@westech-inc.com  
www.westech-inc.com

## Doors/Hatches

## NEFCO Systems, Inc.

Palm Beach Gardens, FL  
561-775-9303 • Fax: 561-775-6043  
sales@nefco.us  
www.nefco.us

## Dredges

### Hydra-Tech Pumps

Nesquehoning, PA  
570-645-3779 • Fax: 570-645-4061  
htpump@hydra-tech.com  
www.hydra-tech.com

### Mud Cat, Division of Ellicott Dredge Technologies

New Richmond, WI  
866-467-4010 • 913-642-5100 • Fax: 913-642-5119  
sales@mudcatdredge.com  
www.mudcatdredge.com

### SRS Crisafulli, Inc.

Glendive, MT  
800-442-7867 • 406-365-3393 • Fax: 406-365-8088  
srsc@crisafulli.com  
www.crisafullipumps.com

## Drives - Variable Frequency (VFD)

### KSB, Inc.

Henrico, VA  
800-945-7867 • 804-222-1818 • Fax: 804-226-6961  
sales@ksbusa.com  
www.ksbusa.com

### Philadelphia Gear - A Timken Brand

King of Prussia, PA  
800-766-5120 • 610-265-3000 • Fax: 610-337-5637  
info@philagear.com  
www.philagear.com

# Custom Dewatering & Composting Solutions.



DSP Screw Press



Rotary Drum Thickener



Agitated and Aerated In-vessel type Composting System (ICS)



3DP Belt Press



Enclosed Gravity Belt Thickener



Skid-Mounted 3DP

- Belt Presses
- Screw Presses
- Rotary Drum Thickeners
- Gravity Belt Thickeners
- Equipment Restoration
- On-Site Service & Mobile Demos
- Complete Compost Facility Design



**Sales:** 518-796-1440

**Fax:** 518-695-5417

**Factory:** 518-695-6851

**Email:** dan@bdpindustries.com



[www.bdpindustries.com](http://www.bdpindustries.com)

**Rebuild-It Service Group, LLC**  
Midvale, UT  
888-709-5676 • Fax: 385-355-6989  
treburn@rebuild-it.com  
www.rebuild-it.com

**WEG Electric Corp**  
Duluth, GA  
800-275-4934  
info-us@weg.net  
www.weg.net/us

## Education/Training

**Activated Carbon Services - PACS**  
Coraopolis, PA  
800-367-2587 • 724-457-6576  
henry@pacslabs.com  
www.pacslabs.com

**AllMax Software, Inc.**  
Kenton, OH  
800-670-1867 • 419-673-8863 • Fax: 419-673-8864  
sales@allmaxsoftware.com  
www.allmaxsoftware.com  
**Ad on page 31**

**Aqua Operations, Inc.**  
Bakersfield, CA  
888-746-6535 • 661-331-1181 • Fax: 661-833-1861  
childerbrand@aquaoperations.com  
www.aquaoperations.com

**Aqua-Aerobic Systems, Inc.**  
Loves Park, IL  
800-940-5008 • 815-654-2501 • Fax: 815-654-2508  
solutions@aqua-aerobic.com  
www.aqua-aerobic.com  
**Ad on page 11**

**Cla-Val**  
Costa Mesa, CA  
800-942-6326 • 949-722-4800 • Fax: 949-574-5703  
info@cla-val.com  
www.cla-val.com

**Hach**  
Loveland, CO  
800-227-4224 • 970-669-3050  
orders@hach.com  
www.hach.com  
**Ad on page 5**

**Hydromantis Environmental Software Solutions, Inc.**  
Hamilton, ON  
Canada  
905-522-0012 • Fax: 905-522-0031  
info@hydromantis.com  
www.hydromantis.com

## Electrical Equipment

**ElectroSwitch Corporation**  
Weymouth, MA  
781-335-5200  
info@electros witch.com  
www.electros witch.com

**Phoenix Contact**  
Middletown, PA  
800-888-7388 • 717-944-1300  
info@phoenixcon.com  
www.phoenixcontact.com/usa\_home

**Ronk Electrical**  
Nokomis, IL  
800-221-7665 • 217-563-8333 • Fax: 217-563-8336  
sales@ronkelectrical.com  
www.ronkelectrical.com  
**Ad on page 116**

**Thermal Edge Inc.**  
Irving, TX  
888-580-0202 • 972-580-0200 • Fax: 972-580-0202  
thermalinfo@thermal-edge.com  
www.thermal-edge.com



**Weidmüller**  
Richmond, VA  
800-849-9343 • Fax: 804-379-2593  
info@weidmuller.com  
www.weidmuller.com

## Enclosure Air Conditioners

**Thermal Edge Inc.**  
Irving, TX  
888-580-0202 • 972-580-0200 • Fax: 972-580-0202  
thermalinfo@thermal-edge.com  
www.thermal-edge.com

## Enclosures

**ClearSpan Fabric Structures**  
South Windsor, CT  
866-643-1010  
trussingquiry@clearspan.com  
www.clearspan.com  
**Ad on page 77**

**Gorman-Rupp Company**  
Mansfield, OH  
419-755-1011 • Fax: 419-755-1251  
grsales@gormanrupp.com  
www.GRpumps.com

**HEMCO Corporation**  
Independence, MO  
800-779-4362 • 816-796-2900 • Fax: 816-796-3333  
info@hemcocorp.com  
www.hemcocorp.com  
**Ad on page 117**

**Howden Roots**  
Connersville, IN  
800-557-6687 • 765-827-9200 • Fax: 765-827-9317  
connersville.customer care@howden.com  
www.howdenroots.com

**Thermal Edge Inc.**  
Irving, TX  
888-580-0202 • 972-580-0200 • Fax: 972-580-0202  
thermalinfo@thermal-edge.com  
www.thermal-edge.com

**Unison Solutions, Inc.**  
Dubuque, IA  
563-585-0967 • Fax: 563-585-0970  
sales@unisonsolutions.com  
www.unisonsolutions.com

**Wastewater Depot, LLC**  
Batavia, OH  
513-732-0129 • Fax: 513-735-1485  
info@wastewaterdepot.com  
www.wastewaterdepot.com

## Energy Management

**BCR Environmental Corporation**  
Jacksonville, FL  
904-819-9170 • Fax: 904-998-3828  
marketing@bcrenv.com  
www.bcrenv.com

**ElectroSwitch Corporation**  
Weymouth, MA  
781-335-5200  
info@electros witch.com  
www.electros witch.com

**Emerson Automation Solutions**  
Pittsburgh, PA  
800-445-9723 • 412-963-4000  
powerwater@emerson.com  
www.emerson.com/water  
**F & V Operations and Resource Management**  
Grand Rapids, MI  
888-773-8806 • 616-588-2900 • Fax: 616-977-1005  
bselover@fv-operations.com  
www.fv-operations.com

**Geomembrane Technologies Inc.**  
Fredericton, NB  
Canada  
855-484-4630 • 506-452-7304 • Fax: 506-452-6625  
covers@gticovers.com  
www.gticovers.com

**Hydromantis Environmental Software Solutions, Inc.**  
Hamilton, ON  
Canada  
905-522-0012 • Fax: 905-522-0031  
info@hydromantis.com  
www.hydromantis.com

**Phoenix Contact**  
Middletown, PA  
800-888-7388 • 717-944-1300  
info@phoenixcon.com  
www.phoenixcontact.com/usa\_home

**Sierra Instruments, Inc.**  
Monterey, CA  
800-866-0200 • 831-373-0200 • Fax: 831-373-4402  
info@sierrainstruments.com  
www.sierrainstruments.com

**Thermal Edge Inc.**  
Irving, TX  
888-580-0202 • 972-580-0200 • Fax: 972-580-0202  
thermalinfo@thermal-edge.com  
www.thermal-edge.com

## Epoxy Coatings

**Environmental Coatings LLC**  
Mesa, AZ  
480-984-7608  
info@sewershield.com  
www.sewershield.com

## Filter Media

**Activated Carbon Services - PACS**  
Coraopolis, PA  
800-367-2587 • 724-457-6576  
henry@pacslabs.com  
www.pacslabs.com

**AdEdge Water Technologies, LLC**  
Duluth, GA  
866-823-3343 • 678-835-0052 • Fax: 678-835-0057  
sales@adedgetechnologies.com  
www.adedgetech.com  
**Ad on page 25**

**Amiad USA**  
Moorestville, NC  
704-662-3133 • Fax: 704-662-3155  
infousa@amiad.com  
www.amiadusa.com

**CEI - Carbon Enterprises Inc.**  
Circleville, OH  
800-344-5770 • Fax: 888-204-9656  
info@ceicompanies.com  
www.ceifiltration.com

**Graver Technologies**  
Glasgow, DE  
302-731-1700 • Fax: 302-369-0938  
info@gravertech.com  
www.gravertech.com

**Komline-Sanderson**  
Peapack, NJ  
800-225-5457 • 908-234-1000 • Fax: 908-234-9487  
info@komline.com  
www.komline.com  
**Ad on page 69**

**Ovivo USA, LLC**  
Austin, TX  
512-834-6000 • Fax: 512-834-6039  
info.us@ovivowater.com  
www.ovivowater.com

**Premier Tech Aqua**  
Riviere-du-Loup, QC  
Canada  
800-632-6356 • 418-867-8883 • Fax: 418-862-6642  
pta@premiertech.com  
www.premiertechaqua.com

**Sierra Environmental Technologies, LLC**  
Wildwood, MO  
636-273-5189 • Fax: 636-273-4509  
dnokes@setodorcontrol.com  
www.setodorcontrol.com

**Simple Solutions Distributing**  
West Milford, NJ  
866-667-8465 • 973-846-7817 • Fax: 973-858-0219  
sales@industrialodorcontrol.com  
www.IndustrialOdorControl.com  
**Ad on page 116**

**Thermal Edge Inc.**  
Irving, TX  
888-580-0202 • 972-580-0200 • Fax: 972-580-0202  
thermalinfo@thermal-edge.com  
www.thermal-edge.com



**Filters - Bag/Cartridge**



**Hayward Flow Control**

Clemmons, NC  
888-429-4635 • Fax: 888-778-8410  
hfcsales@hayward.com  
www.haywardflowcontrol.com

Ad on page 15

**Filters - Membrane**

**Graver Technologies**

Glasgow, DE  
302-731-1700 • Fax: 302-369-0938  
info@gravertech.com  
www.gravertech.com

**Huber Technology, Inc.**

Huntersville, NC  
704-949-1010 • Fax: 704-949-1020  
marketing@hhusa.net  
www.huberforum.net

Ad on page 9

**Ovivo USA, LLC**

Austin, TX  
512-834-6000 • Fax: 512-834-6039  
info.us@ovivowater.com  
www.ovivowater.com

**Premier Tech Aqua**

Riviere-du-Loup, QC  
Canada  
800-632-6356 • 418-867-8883 • Fax: 418-862-6642  
pta@premiertech.com  
www.premiertechaqua.com

**Smith & Loveless, Inc.**

Lenexa, KS  
800-898-9122 • 913-888-5201  
answers@smithandloveless.com  
www.smithandloveless.com

**Filters - Sand & Gravel**

**Amiad USA**

Moorestville, NC  
704-662-3133 • Fax: 704-662-3155  
info@amiad.com  
www.amiadusa.com

**CEI - Carbon Enterprises Inc.**

Circleville, OH  
800-344-5770 • Fax: 888-204-9656  
info@ceicompanies.com  
www.ceifiltration.com

**Parkson Corporation**

Ft. Lauderdale, FL  
888-727-5766 • Fax: 954-974-6182  
technology@parkson.com  
www.parkson.com

**Smith & Loveless, Inc.**

Lenexa, KS  
800-898-9122 • 913-888-5201  
answers@smithandloveless.com  
www.smithandloveless.com

**Filters - Trickling**

**AMWELL, A Div. of McNish Corp.**

Aurora, IL  
630-898-6900 • Fax: 630-898-1647  
phaizman@amwell-inc.com  
www.amwell-inc.com

**Rebuild-It Service Group, LLC**

Midvale, UT  
888-709-5676 • Fax: 385-355-6989  
treburn@rebuild-it.com  
www.rebuild-it.com

**Filtration Equipment/  
Systems**

**AdEdge Water Technologies, LLC**

Duluth, GA  
866-823-3343 • 678-835-0052 • Fax: 678-835-0057  
sales@adedgetechnologies.com  
www.adedgetech.com

Ad on page 25

**Alfa Laval Inc.**

Richmond, VA  
866-253-2528  
customerservice.usa@alfalaval.com  
www.alfalaval.us

**Amiad USA**

Moorestville, NC  
704-662-3133 • Fax: 704-662-3155  
info@amiad.com  
www.amiadusa.com

**Aqseptence Group Inc.**

New Brighton, MN  
800-833-9473 • 651-636-3900 • Fax: 651-638-3171  
matthew.bentley@aqseptence.com  
www.johnsonscreeens.com



**AQUA-AEROBIC  
SYSTEMS, INC.**

**Aqua-Aerobic Systems, Inc.**

Loves Park, IL  
800-940-5008 • 815-654-2501 • Fax: 815-654-2508  
solutions@aquaaerobic.com  
www.aqua-aerobic.com

Ad on page 11

**BDP Industries**

Greenwich, NY  
518-695-6851 • Fax: 518-695-5417  
dan@bdpindustries.com  
www.bdpindustries.com

Ad on page 73



**LAB TESTED, FIELD PROVEN!**

**Visit us at ACE 2017!  
BOOTH #1809!**

Our factory powder coated Bolted Steel Tanks have been laboratory tested with outstanding results. Tank performance in real life is equally important to lab testing and our tanks have proven they are the best value without sacrificing longevity or durability.



**GET THE FACTS!:**

**888 - 499 - 8109**  
**factorypowdercoated.com**



**BioAir Solutions LLC**  
Voorhees, NJ  
856-258-6969 • Fax: 856-258-6975  
cwest@bioairsolutions.com  
www.bioairsolutions.com

**CEI - Carbon Enterprises Inc.**  
Circleville, OH  
800-344-5770 • Fax: 888-204-9656  
info@ceicompanies.com  
www.ceifiltration.com

**Evoqua Water Technologies LLC**  
Warrendale, PA  
800-466-7873 • 724-772-0044  
municipalmarketing@evoqua.com  
www.evoqua.com

**Flottweg Separation Technology, Inc.**  
Independence, KY  
859-448-2331 • Fax: 859-448-2333  
sales@flottweg.net  
www.flottweg.com

**Fluidyne Corporation**  
Cedar Falls, IA  
319-266-9967 • Fax: 319-277-6034  
fluidyne@fluidynecorp.com  
www.fluidynecorp.com

**Graver Technologies**  
Glasgow, DE  
302-731-1700 • Fax: 302-369-0938  
info@gravertech.com  
www.gravertech.com

**HEMCO Corporation**  
Independence, MO  
800-779-4362 • 816-796-2900 • Fax: 816-796-3333  
info@hemcocorp.com  
www.hemcocorp.com

**Ad on page 117**

**Huber Technology, Inc.**  
Huntersville, NC  
704-949-1010 • Fax: 704-949-1020  
marketing@hhusa.net  
www.huberforum.net

**Ad on page 9**

**International Products Corporation**  
Burlington, NJ  
609-386-8770 • Fax: 609-386-8438  
mkt@ipcol.com  
www.ipcol.com



**Cleaner Water for a Brighter Future®**  
**Lakeside Equipment Corporation**  
Bartlett, IL  
630-837-5640 • Fax: 630-837-5647  
sales@lakeside-equipment.com  
www.lakeside-equipment.com

**Ad on page 3**



**Ovivo USA, LLC**  
Austin, TX  
512-834-6000 • Fax: 512-834-6039  
info.us@ovivowater.com  
www.ovivowater.com

**Park Process**  
Houston, TX  
855-511-7275 • 713-849-7189 • Fax: 713-937-4254  
rcaughman@parkprocess.com  
www.parkprocess.com

**Ad on page 116**

**Parkson Corporation**  
Ft. Lauderdale, FL  
888-727-5766 • Fax: 954-974-6182  
technology@parkson.com  
www.parkson.com



**Rain for Rent**  
Bakersfield, CA  
800-742-7246 • 661-399-9124  
info@rainforrent.com  
www.rainforrent.com



**Ruthman Companies**  
Cincinnati, OH  
859-824-3100 • Fax: 859-824-7248  
www.gusher.com/contact-us  
www.ruthmancompanies.com/ruthman-companies

**Ad on page 37**

**Smith & Loveless, Inc.**  
Lenexa, KS  
800-898-9122 • 913-888-5201  
answers@smithandloveless.com  
www.smithandloveless.com

**Sure Flow Products, LLC**  
Wixom, MI  
248-380-3569 • Fax: 248-380-3568  
sales@sureflowproducts.com  
www.flowmetersource.com

**Thermal Edge Inc.**  
Irving, TX  
888-580-0202 • 972-580-0200 • Fax: 972-580-0202  
thermalinfo@thermal-edge.com  
www.thermal-edge.com

**Triplepoint Environmental**  
Oak Park, IL  
800-654-9307 • Fax: 312-957-4712  
info@triplepointwater.com  
www.tpev.com

**VAF Filtration Systems**  
Arvada, CO  
303-425-4242 • Fax: 303-425-0112  
sales.vaf@evoqua.com  
www.vafusa.com



**Westech Engineering**  
Salt Lake City, UT  
801-265-1000 • Fax: 801-265-1080  
info@westech-inc.com  
www.westech-inc.com

## Flare Systems



**Varec Biogas**  
Huntington Beach, CA  
866-424-6427 • Fax: 714-952-2701  
info@varec-biogas.com  
www.varec-biogas.com

## Flow/Level Switches



**Delta M Corporation**  
Oak Ridge, TN  
800-922-0083 • 865-483-1569 • Fax: 865-483-1142  
sales@deltamcorp.com  
www.deltamcorp.com

**FCl - Fluid Components International**  
San Marcos, CA  
800-854-1993 • 760-744-6950 • Fax: 760-736-6250  
eflow@fluidcomponents.com  
www.fluidcomponents.com

**Harwil Corp.**  
Oxnard, CA  
805-988-6800 • Fax: 805-988-6804  
sales@harwil.com  
www.harwil.com

## Flowmeters

**BinMaster Level Controls**  
Lincoln, NE  
800-278-4241 • 402-434-9102 • Fax: 402-434-9133  
info@binmaster.com  
www.binmaster.com



**Blue-White Industries**  
Huntington Beach, CA  
714-893-8529 • Fax: 714-894-9492  
sales@blue-white.com  
www.blue-white.com

**Ad on page 2**



**Delta M Corporation**  
Oak Ridge, TN  
800-922-0083 • 865-483-1569 • Fax: 865-483-1142  
sales@deltamcorp.com  
www.deltamcorp.com

**Emerson / Rosemount**  
Shakopee, MN  
800-854-8257 • 952-906-8888  
liquid.csr@emerson.com  
www.rosemount.com

## Endress+Hauser

**Endress+Hauser**  
Greenwood, IN  
888-363-7377 • Fax: 317-535-8498  
info@us.endress.com  
www.us.endress.com



**FCl - Fluid Components International**  
San Marcos, CA  
800-854-1993 • 760-744-6950 • Fax: 760-736-6250  
eflow@fluidcomponents.com  
www.fluidcomponents.com

**Hawk Measurement**  
Lawrence, MA  
888-429-5538 • 978-304-3000 • Fax: 978-304-1462  
info@hawkmeasure.com  
www.hawkmeasure.com

**McCrometer Inc.**  
Hemet, CA  
800-220-2279 • 951-652-6811 • Fax: 951-652-3078  
customerservice@mccrometer.com  
www.mccrometer.com



**Sierra Instruments, Inc.**  
Monterey, CA  
800-866-0200 • 831-373-0200 • Fax: 831-373-4402  
info@sierrainstruments.com  
www.sierrainstruments.com

**Sure Flow Products, LLC**  
Wixom, MI  
248-380-3569 • Fax: 248-380-3568  
sales@sureflowproducts.com  
www.flowmetersource.com

## FOG Controls



**Anue Water Technologies, Inc.**  
Oceanside, CA  
760-727-2683  
info@anuewater.com  
www.anuewater.com

**Byo-Gon, Inc.**  
Charleston, SC  
888-796-4661 • 843-822-3415 • Fax: 843-606-6318  
info@byogon.com  
www.byogon.com

**Ad on page 117**



**In-Pipe Technology**  
Wood Dale, IL  
888-325-5033 • 630-509-2488 • Fax: 630-509-2490  
jwilliams@in-pipe.com  
www.in-pipe.com



**Sierra Environmental Technologies, LLC**  
Wildwood, MO  
636-273-5189 • Fax: 636-273-4509  
dnokes@setodorcontrol.com  
www.setodorcontrol.com

**U.S. Water Services Corporation**  
New Port Richey, FL  
866-753-8292 • 515-269-2336 • Fax: 727-848-7701  
info@uswatercorp.net  
www.uswatercorp.com

**FOG Screening**

**Enviro-Care**  
A WAMGROUP® Company

**Enviro-Care Company**  
Gurnee, IL  
815-636-8306 • Fax: 847-672-7968  
ecsales@enviro-care.com  
www.enviro-care.com  
Ad on page 59

**Fume Hoods**

**HEMCO Corporation**  
Independence, MO  
800-779-4362 • 816-796-2900 • Fax: 816-796-3333  
info@hemcocorp.com  
www.hemcocorp.com  
Ad on page 117

**Gas Monitors/Detection**

**Analytical Technology, Inc.**  
Collegeville, PA  
800-959-0299 • 610-917-0991 • Fax: 610-917-0992  
sales@analyticaltechnology.com  
www.analyticaltechnology.com  
Ad on page 118

**Eagle Microsystems, Inc.**  
Pottstown, PA  
800-780-8636 • 610-323-2250 • Fax: 610-323-0114  
info@eaglemicrosystems.com  
www.eaglemicrosystems.com

**Emerson / Rosemount**  
Shakopee, MN  
800-854-8257 • 952-906-8888  
liquid.csc@emerson.com  
www.rosemount.com

**ENMET**  
Ann Arbor, MI  
800-521-2978 • 734-761-1270 • Fax: 734-761-3220  
info@enmet.com  
www.enmet.com

**Hawkins Water Treatment Group**  
Roseville, MN  
800-328-5460 • 612-331-6910 • Fax: 612-331-5304  
laura.eilek@hawkinsinc.com  
www.hawkinsinc.com

**INDUSTRIAL SCIENTIFIC**

**Industrial Scientific**  
Pittsburgh, PA  
412-788-4353 • Fax: 412-788-8353  
info@indsci.com  
www.indsci.com

**MRP**  
MILWAUKEE RUBBER PRODUCTS  
**Milwaukee Rubber Products, Inc.**  
Menomonee Falls, WI  
800-325-3730 • 262-781-7888 • Fax: 262-781-1742  
sales@milwaukeerubber.com  
www.milwaukeerubber.com

**Praxair, Inc.**  
Burr Ridge, IL  
800-772-9247 • 630-320-4000 • Fax: 630-320-4508  
info@praxair.com  
www.praxair.com/wastewater

**RKI Instruments, Inc.**  
Union City, CA  
800-754-5165 • 510-441-5656 • Fax: 510-441-5650  
orders@rkiinstruments.com  
www.rkiinstruments.com

**Sierra Instruments, Inc.**  
Monterey, CA  
800-866-0200 • 831-373-0200 • Fax: 831-373-4402  
info@sierrainstruments.com  
www.sierrainstruments.com

**Sure Flow Products, LLC**  
Wixom, MI  
248-380-3569 • Fax: 248-380-3568  
sales@sureflowproducts.com  
www.flowmetersource.com

**Gates/Weirs/Flumes/  
Booms/Baffles**

**Alfa Laval Inc.**  
Richmond, VA  
866-253-2528  
customerservice.usa@alfalaval.com  
www.alfalaval.us

**Environetics, Inc.**  
Lockport, IL  
815-838-8331 • Fax: 815-838-8336  
info@environeticsinc.com  
www.environeticsinc.com

**Fibergrate Composite Structures**  
Dallas, TX  
800-527-4043 • 972-250-1633 • Fax: 972-250-1530  
info@fibergrate.com  
www.fibergrate.com

**NEFCO Systems, Inc.**  
Palm Beach Gardens, FL  
561-775-9303 • Fax: 561-775-6043  
sales@neco.us  
www.neco.us

**Gauges**

**AMETEK Drexelbrook**  
Horsham, PA  
215-674-1234 • Fax: 215-674-2731  
drexelbrook.info@ametek.com  
www.drexelbrook.com

**Busch Vacuum Pumps and Systems**  
Virginia Beach, VA  
800-872-7867 • 757-463-7800 • Fax: 757-463-7407  
marketing@buschusa.com  
www.buschusa.com



**WE MANUFACTURE • WE INSTALL  
WE SAVE YOU MONEY**

**BUILDINGS OF 1,000 USES**



<b>Fabric Structures</b> Natural Light & Low Cost Per Sq Ft	<b>Hybrid Buildings</b> Benefits of Metal & Fabric Buildings	<b>Foundation Solutions</b> Build Anywhere & Quick Construction
--	---	--

**ZERO PERCENT FINANCING AVAILABLE** RESTRICTIONS MAY APPLY **MADE IN USA**

FREE INFO – SEE ADVERTISER INDEX



**BARGE OFFERS SAFE WORK  
AREA AND BOOSTS CONFIDENCE**

**For Work On Treatment Ponds and Lagoons.**

- 8' x 12' platform
- Approximate weight 550lbs
- Approximate capacity 1400lbs
- 23" diameter aluminum pontoons - #5052 x .080 wall thickness
- Heavy duty outboard motor mount for small gasoline or electric motors
- Vinyl decking for easy clean up
- Heavy duty protective hand rail with 1/4 rail spacers
- Protective lower rail (keeps tools on board)
- Safety chains
- Welded lifting eyes at each corner

**OPTIONS:**

- > Battery box with solar charger
- > Boarding ladder
- > 1000-lb. capacity crane
- > Galvanized trailer
- > Life ring
- > Pivot arms (Used to secure barge to aerator tubes when service is being performed on diffuser drop tubes.)

**AMERICAN PLEASURE  
PRODUCTS INC.**

ROSE CITY, MI  
INFO@AQUACYCLEUSA.COM

**989.685.2697**

FREE INFO – SEE ADVERTISER INDEX

**Emerson / Rosemount**  
Shakopee, MN  
800-854-8257 • 952-906-8888  
liquid.csc@emerson.com  
www.rosemount.com

**Endress+Hauser** 

**Endress+Hauser**  
Greenwood, IN  
888-363-7377 • Fax: 317-535-8498  
info@us.endress.com  
www.us.endress.com

**Hawk Measurement**  
Lawrence, MA  
888-429-5538 • 978-304-3000 • Fax: 978-304-1462  
info@hawkmeasure.com  
www.hawkmeasure.com

**Keller America Inc.**  
Newport News, VA  
877-253-5537 • 757-596-6680 • Fax: 757-596-6659  
sales@kelleramerica.com  
www.kelleramerica.com  
**Ad on page 7**

**Milwaukee Rubber Products, Inc.**  
Menomonee Falls, WI  
800-325-3730 • 262-781-7888 • Fax: 262-781-1742  
sales@milwaukeerubber.com  
www.milwaukeerubber.com

**MoistTech Corp.**  
Sarasota, FL  
941-351-7870  
www.moisttech.com/

**PMC Engineering**  
Danbury, CT  
203-792-8686 • Fax: 203-743-2051  
sales@pmc1.com  
www.pmc1.com

**Shand & Jurs**  
Hillside, IL  
708-236-6000 • Fax: 708-236-6006  
sales@ljtechnologies.com  
www.ljtechnologies.com  
**Ad on page 29**

**Gears/Gearboxes**



**Philadelphia Gear - A Timken Brand**  
King of Prussia, PA  
800-766-5120 • 610-265-3000 • Fax: 610-337-5637  
info@philagear.com  
www.philagear.com

**Generators**

**Philadelphia Gear - A Timken Brand**  
King of Prussia, PA  
800-766-5120 • 610-265-3000 • Fax: 610-337-5637  
info@philagear.com  
www.philagear.com

**Ronk Electrical**  
Nokomis, IL  
800-221-7665 • 217-563-8333 • Fax: 217-563-8336  
sales@ronkelectrical.com  
www.ronkelectrical.com  
**Ad on page 116**

**Sunbelt Rentals**  
Fort Mill, SC  
800-736-2504  
www.sunbeltrentals.com  
**Ad on page 27**

**WEG Electric Corp**  
Duluth, GA  
800-275-4934  
info-us@weg.net  
www.weg.net/us

**Geomembranes/  
Geosynthetics**

**Agru America, Inc.**  
Georgetown, SC  
800-373-2478 • 843-546-0600 • Fax: 843-527-2738  
salesmkg@agruamerica.com  
www.agruamerica.com

**Environetics, Inc.**  
Lockport, IL  
815-838-8331 • Fax: 815-838-8336  
info@environeticsinc.com  
www.environeticsinc.com

**Geomembrane Technologies Inc.**  
Fredericton, NB  
Canada  
855-484-4630 • 506-452-7304 • Fax: 506-452-6625  
covers@gticovers.com  
www.gticovers.com

**Grating/Handrails/Ladders**

**Fibergrate Composite Structures**  
Dallas, TX  
800-527-4043 • 972-250-1633 • Fax: 972-250-1530  
info@fibergrate.com  
www.fibergrate.com

**Peabody Engineering and Supply Inc.**  
Corona, CA  
877-734-3759 • Fax: 951-734-4111  
sales@4peabody.com  
www.4peabody.com

**Grease Removal Equipment**

  
**Anue Water Technologies, Inc.**  
Oceanside, CA  
760-727-2683  
info@anuewater.com  
www.anuewater.com

**Byo-Gon, Inc.**  
Charleston, SC  
888-796-4661 • 843-822-3415 • Fax: 843-606-6318  
info@byogon.com  
www.byogon.com  
**Ad on page 117**

**KCH Engineered Systems**  
Forest City, NC  
828-245-9836  
khankinson@kchservices.com  
www.kchservices.com

**NozzTeq Inc.**  
Clearwater, FL  
866-620-5915 • 727-223-4979 • Fax: 603-413-6744  
info@nozzteq.com  
www.nozzteq.com

**Sierra Environmental Technologies, LLC**  
Wildwood, MO  
636-273-5189 • Fax: 636-273-4509  
dnokes@setodorcontrol.com  
www.setodorcontrol.com

**Vaughan Company, Inc.**  
Montesano, WA  
888-249-2467 • 360-249-4042 • Fax: 360-249-6155  
info@chopperpumps.com  
www.chopperpumps.com  
**Ad on page 120**

**Grinders/Shredders**

**Boerger, LLC**  
Chanhassen, MN  
612-435-7300 • Fax: 612-435-7301  
america@boerger.com  
www.boerger.com  
**Ad on page 55**

**NETZSCH Pumps North America, LLC**  
Exton, PA  
610-363-8010 • Fax: 610-363-0971  
npa@netsch.com  
www.pumps.netsch.com

**SEPEX Inc.**  
Enon, OH  
937-864-7150 • Fax: 937-864-7157  
sales.us@sepepex.com  
www.sepepex.com  
**Ad on page 71**

**Grit Handling/Removal/  
Hauling**

**AMWELL, A Div. of McNish Corp.**  
Aurora, IL  
630-898-6900 • Fax: 630-898-1647  
phaizman@amwell-inc.com  
www.amwell-inc.com

**Aqseptence Group Inc.**  
New Brighton, MN  
800-833-9473 • 651-636-3900 • Fax: 651-638-3171  
matthew.bentley@aqseptence.com  
www.johnsonscreens.com

**CleanTek Water Solutions**  
Fridley, MN  
866-929-7773  
info@cleantekwater.com  
www.cleantekwater.com



**DRYCAKE**  
Vancouver, BC  
Canada  
877-379-2253 • 604-535-2238  
sales@drycake.com  
www.drycake.com

  
**Duramax Cast Stainless Steel  
Chain & Equipment Products**  
Pewaukee, WI  
800-691-0998 • 262-691-0998 • Fax: 262-691-0992  
www.duramaxchain.com

**Enviro-Care Company**  
Gurnee, IL  
815-636-8306 • Fax: 847-672-7968  
ecsales@enviro-care.com  
www.enviro-care.com  
**Ad on page 59**

**Fluidyne Corporation**  
Cedar Falls, IA  
319-266-9967 • Fax: 319-277-6034  
fluidyne@fluidynecorp.com  
www.fluidynecorp.com

**Garland Manufacturing Company**  
Saco, ME  
800-727-1900 • 207-283-3693 • Fax: 207-283-4834  
wastewater@garlandmfg.com  
www.garlandmfg.com/plastics/wastewater.html  
**Ad on page 89**

**Huber Technology, Inc.**  
Huntersville, NC  
704-949-1010 • Fax: 704-949-1020  
marketing@hhusa.net  
www.huberforum.net  
**Ad on page 9**

  
**Hydro International**  
Hillsboro, OR  
866-615-8130 • 503-615-8130 • Fax: 503-615-2906  
questions@hydro-int.com  
www.hydro-int.com  
**Ad on page 63**

**JDV Equipment Corporation**  
Dover, NJ  
973-366-6556 • Fax: 973-366-3193  
sales@jdvequipment.com  
www.jdvequipment.com  
**Ad on page 83**

  
**Cleaner Water for a Brighter Future®  
Lakeside Equipment Corporation**  
Bartlett, IL  
630-837-5640 • Fax: 630-837-5647  
sales@lakeside-equipment.com  
www.lakeside-equipment.com  
**Ad on page 3**

**Ovivo USA, LLC**  
Austin, TX  
512-834-6000 • Fax: 512-834-6039  
info.us@ovivowater.com  
www.ovivowater.com

**Park Process**  
Houston, TX  
855-511-7275 • 713-849-7189 • Fax: 713-937-4254  
rcoughman@parkprocess.com  
www.parkprocess.com  
**Ad on page 116**



**Paxxo**  
Newnan, GA  
770-502-0055 • Fax: 770-502-0088  
chris.pettigrew@paxxo.com  
www.paxxo.com

**Red Valve Co. / Tideflex Technologies**  
Carnegie, PA  
412-279-0044 • Fax: 412-279-7878  
sales@redvalve.com  
www.redvalve.com

Ad on page 35

**ScreenCo Systems LLC**  
Genesee, ID  
208-790-8770  
sales@screenco.com  
www.screenco.com

Ad on page 116



**Smith & Loveless, Inc.**  
Lenexa, KS  
800-898-9122 • 913-888-5201  
answers@smithandloveless.com  
www.smithandloveless.com

**U.S. Submergent Technologies LLC**  
Sarasota, FL  
844-765-7866 • 941-444-1440 • Fax: 941-219-3080  
info@ussubmergent.com  
www.ussubmergent.com

## WEMCO®

**Weir Specialty Pumps (WEMCO)**  
Salt Lake City, UT  
801-359-8731 • Fax: 801-530-7828  
wemco@mail.weir  
www.global.weir

## Groundwater Remediation/ Treatment

**AdEdge Water Technologies, LLC**  
Duluth, GA  
866-823-3343 • 678-835-0052 • Fax: 678-835-0057  
sales@adedge.com  
www.adedge.com

Ad on page 25

**CEI - Carbon Enterprises Inc.**  
Circleville, OH  
800-344-5770 • Fax: 888-204-9656  
info@ceicompanies.com  
www.ceifiltration.com

**KCH Engineered Systems**  
Forest City, NC  
828-245-9836  
khankinson@kchservices.com  
www.kchservices.com



**UV Pure Technologies, Inc.**  
Toronto, ON  
Canada  
888-407-9997 • 416-208-9884 • Fax: 416-208-5808  
info@uvpure.com  
www.uvpure.com

## Headworks

**Aqseptence Group Inc.**  
New Brighton, MN  
800-833-9473 • 651-636-3900 • Fax: 651-638-3171  
matthew.bentley@aqseptence.com  
www.johnsonscreens.com



**Aqualitec Corp.**  
Los Angeles, CA  
855-650-2214  
info@aqualitec.com  
www.aqualitec.com



**CleanTek Water Solutions**  
Fridley, MN  
866-929-7773  
info@cleantekwater.com  
www.cleantekwater.com



**DRYCAKE**  
Vancouver, BC  
Canada  
877-379-2253 • 604-535-2238  
sales@drycake.com  
www.drycake.com

**Duperon Corporation**  
Saginaw, MI  
800-383-8479 • 989-754-8800 • Fax: 989-754-2175  
bbauer@duperon.com  
www.duperon.com



**Enviro-Care Company**  
Gurnee, IL  
815-636-8306 • Fax: 847-672-7968  
ecsales@enviro-care.com  
www.enviro-care.com

Ad on page 59

**Headworks International, Inc.**  
Houston, TX  
713-647-6667 • Fax: 713-647-0999  
hw@headworksintl.com  
www.headworksintl.com

# Transform your Clarifier Cleaning with the NEW Weir-Wolf™!



The Ford Hall Company's Algae Sweep Automation weir cleaning system for clarifiers and thickeners has improved... has transformed into the **Weir-Wolf™!**

### The Weir-Wolf™

- ELIMINATES** man-hour cost associated with daily hosing and weekly cleanings
- ADDRESSES** safety concerns associated with entering the clarifiers for cleanings
- OPTIMIZES** clarifier/thickener performance
- ENHANCES** clarifier/thickener appearances
- ASSIST UV** and disinfection systems
- IMPROVES** TSS and sample readings to maintain compliance by providing constant cleaning

The Weir-Wolf is still designed to clean algae from secondary clarifiers but can also be used in municipal and industrial applications to remove debris and non-algae build up in primary clarifiers, intermediate tanks and thickeners; whether they are covered or open to the elements.



For more information, please visit our website [www.weir-wolf.com](http://www.weir-wolf.com) or call 800-928-2070

FREE INFO – SEE ADVERTISER INDEX

AWWA ACE  
BOOTH  
#2531



## WHEN SPEED & CUSTOMIZATION ARE TOP PRIORITIES

You choose Singer Valve's  
**LCP-TP Level Control Panel**

Innovative electronics that produce better results with none of the usual headaches.



VISIT US TODAY! [SINGERVAVE.COM](http://SINGERVAVE.COM)

FREE INFO – SEE ADVERTISER INDEX

**HUBER**  
TECHNOLOGY  
WASTE WATER Solutions

**Huber Technology, Inc.**  
Huntersville, NC  
704-949-1010 • Fax: 704-949-1020  
marketing@hhusa.net  
www.huberforum.net  
**Ad on page 9**

**Hydro International**  
Hillsboro, OR  
866-615-8130 • Fax: 503-615-8130 • Fax: 503-615-2906  
questions@hydro-int.com  
www.hydro-int.com  
**Ad on page 63**

**JDV Equipment Corporation**  
Dover, NJ  
973-366-6556 • Fax: 973-366-3193  
sales@jdvequipment.com  
www.jdvequipment.com  
**Ad on page 83**



Cleaner Water for a Brighter Future®  
**Lakeside Equipment Corporation**  
Bartlett, IL  
630-837-5640 • Fax: 630-837-5647  
sales@lakeside-equipment.com  
www.lakeside-equipment.com  
**Ad on page 3**

**LANXESS / International Dioxide, Inc.**  
North Kingstown, RI  
401-295-8800 • Fax: 401-295-7108  
adox@lanxess.com  
www.lanxess.com

**NEFCO Systems, Inc.**  
Palm Beach Gardens, FL  
561-775-9303 • Fax: 561-775-6043  
sales@neco.us  
www.neco.us



**Ovivo USA, LLC**  
Austin, TX  
512-834-6000 • Fax: 512-834-6039  
info.us@ovivowater.com  
www.ovivowater.com

**Parkson Corporation**  
Ft. Lauderdale, FL  
888-727-5766 • Fax: 954-974-6182  
technology@parkson.com  
www.parkson.com

**Paxxo**  
Newnan, GA  
770-502-0055 • Fax: 770-502-0088  
chris.pettigrew@paxxo.com  
www.paxxo.com

**Smith & Loveless, Inc.**  
Lenexa, KS  
800-898-9122 • 913-888-5201  
answers@smithandloveless.com  
www.smithandloveless.com

**USP Technologies (US Peroxide)**  
Atlanta, GA  
877-346-4262 • 404-352-6070 • Fax: 404-352-6077  
info@usp technologies.com  
www.usptechnologies.com



**Westech Engineering**  
Salt Lake City, UT  
801-265-1000 • Fax: 801-265-1080  
info@westech-inc.com  
www.westech-inc.com

**Heat Exchangers**

**Alfa Laval Inc.**  
Richmond, VA  
866-253-2528  
customerservice.usa@alfalaval.com  
www.alfalaval.us

**Chromalox**  
Pittsburgh, PA  
800-443-2640 • 412-967-3800 • Fax: 412-967-5148  
sales@chromalox.com  
www.chromalox.com



**CleanTek Water Solutions**  
Fridley, MN  
866-929-7773  
info@cleantekwater.com  
www.cleantekwater.com

**Gorman-Rupp Company**  
Mansfield, OH  
419-755-1011 • Fax: 419-755-1251  
g-sales@gormanrupp.com  
www.GRpumps.com

**Gryphon Environmental**  
Owensboro, KY  
270-485-2680  
info@2gryphon.com  
www.2gryphon.com

**HRS HEAT EXCHANGERS**  
Marietta, GA  
770-726-3540  
info@hrs-heatexchangers.com  
www.hrs-heatexchangers.com

**JDV Equipment Corporation**  
Dover, NJ  
973-366-6556 • Fax: 973-366-3193  
sales@jdvequipment.com  
www.jdvequipment.com  
**Ad on page 83**

**Parker Boiler Co.**  
Los Angeles, CA  
323-727-9800 • Fax: 323-722-2848  
mleeming@parkerboiler.com  
www.parkerboiler.com

**Pick Heaters, Inc.**  
West Bend, WI  
262-338-1191 • Fax: 262-338-8489  
info1@pickheaters.com  
www.pickheaters.com

**Sierra Environmental Technologies, LLC**  
Wildwood, MO  
636-273-5189 • Fax: 636-273-4509  
dnokes@setodorcontrol.com  
www.setodorcontrol.com

**Sunbelt Rentals**  
Fort Mill, SC  
800-736-2504  
www.sunbeltrentals.com  
**Ad on page 27**

**Thermal Edge Inc.**  
Irving, TX  
888-580-0202 • 972-580-0200 • Fax: 972-580-0202  
thermalinfo@thermal-edge.com  
www.thermal-edge.com

**Walker Process Equipment, A Div. of McNish Corp.**  
Aurora, IL  
800-992-5537 • 630-892-7921 • Fax: 630-892-7951  
walker.process@walker-process.com  
www.walker-process.com  
**Ad on page 87**

**Heat Trace Systems**

**Chromalox**  
Pittsburgh, PA  
800-443-2640 • 412-967-3800 • Fax: 412-967-5148  
sales@chromalox.com  
www.chromalox.com

**Hose/Tubing**

**Flowrox, Inc.**  
Linthicum, MD  
410-636-2250 • Fax: 410-636-9062  
sales-us@flowrox.com  
www.flowrox.com



**Milwaukee Rubber Products, Inc.**  
Menomonee Falls, WI  
800-325-3730 • 262-781-7888 • Fax: 262-781-1742  
sales@milwaukeerubber.com  
www.milwaukeerubber.com

**SRS Crisafulli, Inc.**  
Glendive, MT  
800-442-7867 • 406-365-3393 • Fax: 406-365-8088  
srsc@crisafulli.com  
www.crisafullipumps.com

**Sunbelt Rentals**  
Fort Mill, SC  
800-736-2504  
www.sunbeltrentals.com  
**Ad on page 27**

**Watson-Marlow Fluid Technology Group**  
Wilmington, MA  
800-282-8823 • 978-658-6168 • Fax: 978-658-0041  
support@wmpg.us  
www.watson-marlow.com  
**Ad on page 53**

**Instrumentation - Analytical**

**Activated Carbon Services - PACS**  
Coraopolis, PA  
800-367-2587 • 724-457-6576  
henry@pacslabs.com  
www.pacslabs.com

**AMETEK Drexelbrook**  
Horsham, PA  
215-674-1234 • Fax: 215-674-2731  
drexelbrook.info@ametek.com  
www.drexelbrook.com

**Analytical Technology, Inc.**  
Collegeville, PA  
800-959-0299 • 610-917-0991 • Fax: 610-917-0992  
sales@analyticaltechnology.com  
www.analyticaltechnology.com  
**Ad on page 118**

**ASA Analytics**  
Waukesha, WI  
262-717-9500 • Fax: 262-717-9530  
info@chemscan.com  
www.asaanalytics.com

**CEM Corporation**  
Matthews, NC  
800-726-3331 • Fax: 704-821-7015  
info@cem.com  
www.cem.com  
**Ad on page 67**

**CHEMetrics, Inc.**  
Midland, VA  
800-356-3072 • 540-788-9026 • Fax: 540-788-4856  
sales@chemetrics.com  
www.chemetrics.com

**Eagle Microsystems, Inc.**  
Pottstown, PA  
800-780-8636 • 610-323-2250 • Fax: 610-323-0114  
info@eaglemicrosystems.com  
www.eaglemicrosystems.com



**Emerson / Rosemount**  
Shakopee, MN  
800-854-8257 • 952-906-8888  
liquid.csc@emerson.com  
www.rosemount.com

**Endress+Hauser**

**Endress+Hauser**  
Greenwood, IN  
888-363-7377 • Fax: 317-535-8498  
info@us.endress.com  
www.us.endress.com

**Force Flow**  
Concord, CA  
800-893-6723 • 925-686-6700 • Fax: 925-686-6713  
info@forceflow.com  
www.forceflow.com  
**Ad on page 89**





**MARSH**  
MCGIRNEY **SIGMA**  
**Hach**  
Loveland, CO  
800-227-4224 • 970-669-3050  
orders@hach.com  
www.hach.com  
**Ad on page 5**

**LaMotte Company**  
Chestertown, MD  
800-344-3100 • 410-778-3100 • Fax: 410-778-6394  
mkt@lamotte.com  
www.lamotte.com

**Lutz-JESCO America Corp.**  
Rochester, NY  
800-554-2762 • 585-426-0990 • Fax: 585-426-4025  
mail@jescoamerica.com  
www.lutzjescoamerica.com

**MoistTech Corp.**  
Sarasota, FL  
941-351-7870  
www.moisttech.com



**Myron L Company**  
Carlsbad, CA  
760-438-2021 • Fax: 760-931-9189  
info@myronl.com  
www.myronl.com  
**Ad on page 57**

**PolyScience**  
Niles, IL  
800-229-7569 • 847-647-0611 • Fax: 847-647-1155  
sales@polyscience.com  
www.polyscience.com

**ProMinent Fluid Controls, Inc.**  
Pittsburgh, PA  
412-787-2484 • Fax: 412-787-0704  
sales@prominent.us  
www.prominent.us

**Sensaphone**  
Aston, PA  
877-373-2700 • 610-558-2700 • Fax: 610-558-0222  
contact@sensaphone.com  
www.sensaphone.com

**Sierra Instruments, Inc.**  
Monterey, CA  
800-866-0200 • 831-373-0200 • Fax: 831-373-4402  
info@sierrainstruments.com  
www.sierrainstruments.com

**Van London Co.**  
Houston, TX  
800-522-7920 • 832-456-6641 • Fax: 832-456-6642  
anna@vanlondon.com  
www.vanlondon.com

**Instrumentation -  
Level Control**

**AMETEK Drexelbrook**  
Horsham, PA  
215-674-1234 • Fax: 215-674-2731  
drexelbrook.info@ametec.com  
www.drexelbrook.com



**BinMaster Level Controls**  
Lincoln, NE  
800-278-4241 • 402-434-9102 • Fax: 402-434-9133  
info@binmaster.com  
www.binmaster.com  
**Ad on page 117**

**Data Flow Systems, Inc.**  
Melbourne, FL  
321-259-5009 • Fax: 321-259-4006  
info@dataflowsys.com  
www.dataflowsys.com



**Delta M Corporation**  
Oak Ridge, TN  
800-922-0083 • 865-483-1569 • Fax: 865-483-1142  
sales@deltamcorp.com  
www.deltamcorp.com

**Eagle Microsystems, Inc.**  
Pottstown, PA  
800-780-8636 • 610-323-2250 • Fax: 610-323-0114  
info@eaglemicrosystems.com  
www.eaglemicrosystems.com

**Emerson / Rosemount**  
Shakopee, MN  
800-854-8257 • 952-906-8888  
liquid.csc@emerson.com  
www.rosemount.com

**Endress+Hauser**

**Endress+Hauser**  
Greenwood, IN  
888-363-7377 • Fax: 317-535-8498  
info@us.endress.com  
www.us.endress.com

**FCI - Fluid Components International**  
San Marcos, CA  
800-854-1993 • 760-744-6950 • Fax: 760-736-6250  
eflow@fluidcomponents.com  
www.fluidcomponents.com

**Force Flow**  
Concord, CA  
800-893-6723 • 925-686-6700 • Fax: 925-686-6713  
info@forceflow.com  
www.forceflow.com  
**Ad on page 89**

**Gorman-Rupp Company**  
Mansfield, OH  
419-755-1011 • Fax: 419-755-1251  
grsales@gormanrupp.com  
www.GRpumps.com

**Harwil Corp.**  
Oxnard, CA  
805-988-6800 • Fax: 805-988-6804  
sales@harwil.com  
www.harwil.com

**Hawk Measurement**  
Lawrence, MA  
888-429-5538 • 978-304-3000 • Fax: 978-304-1462  
info@hawkmeasure.com  
www.hawkmeasure.com



**The DelPAC® Difference ...  
Continuous Innovation  
of Coagulant Chemistry**



To Learn More Visit [www.usalco.com](http://www.usalco.com)  
or Call 1-800-882-3883

FREE INFO – SEE ADVERTISER INDEX



**suc·ces·sion** [suhk-sesh-uhn]

**NOUN**  
The coming of one person or thing after another in order  
or sequence.

*“Centrisys takes succession planning seriously - actively recruiting,  
developing and training the next generation of centrifuge  
service technicians.”*



Designed & Built  
in the U.S.A.



Discover more at [Centrisys.com](http://Centrisys.com)

FREE INFO – SEE ADVERTISER INDEX

**Keller America Inc.**

Newport News, VA  
877-253-5537 • 757-596-6680 • Fax: 757-596-6659  
sales@kelleramerica.com  
www.kelleramerica.com

Ad on page 7

**McCrometer Inc.**

Hemet, CA  
800-220-2279 • 951-652-6811 • Fax: 951-652-3078  
customerservice@mccrometer.com  
www.mccrometer.com

**Myron L Company**

Carlsbad, CA  
760-438-2021 • Fax: 760-931-9189  
info@myronl.com  
www.myronl.com

Ad on page 57

**Peabody Engineering and Supply Inc.**

Corona, CA  
877-734-3759 • Fax: 951-734-4111  
sales@4peabody.com  
www.4peabody.com



**PMC Engineering**

Danbury, CT  
203-792-8686 • Fax: 203-743-2051  
sales@pmc1.com  
www.pmc1.com

**PRIMEX**

Detroit Lakes, MN  
888-342-5753 • 218-847-1317 • Fax: 218-847-4617  
info@primexcontrols.com  
www.primexcontrols.com

**Rain for Rent**

Bakersfield, CA  
800-742-7246 • 661-399-9124  
info@rainforrent.com  
www.rainforrent.com

**Sensaphone**

Aston, PA  
877-373-2700 • 610-558-2700 • Fax: 610-558-0222  
contact@sensaphone.com  
www.sensaphone.com

**Sierra Instruments, Inc.**

Monterey, CA  
800-866-0200 • 831-373-0200 • Fax: 831-373-4402  
info@sierrainstruments.com  
www.sierrainstruments.com

**Instrumentation - Process Control**

**Aerzen USA**

Coatesville, PA  
610-380-0244  
aerzen@aerzenusa.com  
www.aerzen.com/en-us/

Ad on page 45

**AMETEK Drexelbrook**

Horsham, PA  
215-674-1234 • Fax: 215-674-2731  
drexelbrook.info@ametec.com  
www.drexelbrook.com

**Aqua-Aerobic Systems, Inc.**

Loves Park, IL  
800-940-5008 • 815-654-2501 • Fax: 815-654-2508  
solutions@aquaaerobic.com  
www.aquaaerobic.com

Ad on page 11

**ASA Analytics**

Waukesha, WI  
262-717-9500 • Fax: 262-717-9530  
info@chemscan.com  
www.asaanalytics.com



**Blue-White Industries**

Huntington Beach, CA  
714-893-8529 • Fax: 714-894-9492  
sales@blue-white.com  
www.blue-white.com

Ad on page 2

**CEM Corporation**

Matthews, NC  
800-726-3331 • Fax: 704-821-7015  
info@cem.com  
www.cem.com

Ad on page 67

**Data Flow Systems, Inc.**

Melbourne, FL  
321-259-5009 • Fax: 321-259-4006  
info@dataflowsys.com  
www.dataflowsys.com



**Delta M Corporation**

Oak Ridge, TN  
800-922-0083 • 865-483-1569 • Fax: 865-483-1142  
sales@deltamcorp.com  
www.deltamcorp.com

**Eagle Microsystems, Inc.**

Patitown, PA  
800-780-8636 • 610-323-2250 • Fax: 610-323-0114  
info@eaglemicrosystems.com  
www.eaglemicrosystems.com

**Emerson Automation Solutions**

Pittsburgh, PA  
800-445-9723 • 412-963-4000  
powerwater@emerson.com  
www.emerson.com/water

**Endress+Hauser**

Greenwood, IN  
888-363-7377 • Fax: 317-535-8498  
info@us.endress.com  
www.us.endress.com

**FCI - Fluid Components International**

San Marcos, CA  
800-854-1993 • 760-744-6950 • Fax: 760-736-6250  
eflow@fluidcomponents.com  
www.fluidcomponents.com

**Force Flow**

Concord, CA  
800-893-6723 • 925-686-6700 • Fax: 925-686-6713  
info@forceflow.com  
www.forceflow.com

Ad on page 89

**Hach**

Loveland, CO  
800-227-4224 • 970-669-3050  
orders@hach.com  
www.hach.com

Ad on page 5

**Hawk Measurement**

Lawrence, MA  
888-429-5538 • 978-304-3000 • Fax: 978-304-1462  
info@hawkmeasure.com  
www.hawkmeasure.com

**Hydromantis Environmental Software Solutions, Inc.**

Hamilton, ON  
Canada  
905-522-0012 • Fax: 905-522-0031  
info@hydromantis.com  
www.hydromantis.com

**IWAKI America**

Holliston, MA  
508-429-1440  
info@iwakiamerica.com  
www.iwakiamerica.com

**Keller America Inc.**

Newport News, VA  
877-253-5537 • 757-596-6680 • Fax: 757-596-6659  
sales@kelleramerica.com  
www.kelleramerica.com

Ad on page 7

**LaMotte Company**

Chestertown, MD  
800-344-3100 • 410-778-3100 • Fax: 410-778-6394  
mkt@lamotte.com  
www.lamotte.com

**Lutz-JESCO America Corp.**

Rochester, NY  
800-554-2762 • 585-426-0990 • Fax: 585-426-4025  
mail@jescoamerica.com  
www.lutzjescoamerica.com

**McCrometer Inc.**

Hemet, CA  
800-220-2279 • 951-652-6811 • Fax: 951-652-3078  
customerservice@mccrometer.com  
www.mccrometer.com

**MoistTech Corp.**

Sarasota, FL  
941-351-7870  
www.moisttech.com/



**Myron L Company**

Carlsbad, CA  
760-438-2021 • Fax: 760-931-9189  
info@myronl.com  
www.myronl.com

Ad on page 57

**PMC Engineering**

Danbury, CT  
203-792-8686 • Fax: 203-743-2051  
sales@pmc1.com  
www.pmc1.com

**Polyscience**

Niles, IL  
800-229-7569 • 847-647-0611 • Fax: 847-647-1155  
sales@polyscience.com  
www.polyscience.com

**ProComSol, Ltd**

Lakewood, OH  
877-221-1551 • 216-221-1550 • Fax: 216-221-1554  
sales@procomsol.com  
www.procomsol.com

Ad on page 85

**Sensaphone**

Aston, PA  
877-373-2700 • 610-558-2700 • Fax: 610-558-0222  
contact@sensaphone.com  
www.sensaphone.com

**Sensorex**

Garden Grove, CA  
800-835-4344 • 714-895-4344  
sales@sensorex.com  
www.sensorex.com

**Sierra Instruments, Inc.**

Monterey, CA  
800-866-0200 • 831-373-0200 • Fax: 831-373-4402  
info@sierrainstruments.com  
www.sierrainstruments.com

**Sure Flow Products, LLC**

Wixom, MI  
248-380-3569 • Fax: 248-380-3568  
sales@sureflowproducts.com  
www.flowmetersource.com

**Trihedral Engineering Limited**

Bedford, NS  
Canada  
800-463-2783 • 902-835-1575 • Fax: 902-835-0369  
pcooke@trihedral.com  
www.trihedral.com

**Instrumentation - Testing**

**CHEMetrics, Inc.**

Midland, VA  
800-356-3072 • 540-788-9026 • Fax: 540-788-4856  
sales@chemetrics.com  
www.chemetrics.com

**Sensorex**

Garden Grove, CA  
800-835-4344 • 714-895-4344  
sales@sensorex.com  
www.sensorex.com

**Ion Exchange Systems**

**AdEdge Water Technologies, LLC**

Duluth, GA  
866-823-3343 • 678-835-0052 • Fax: 678-835-0057  
sales@adedgetechnologies.com  
www.adedgetech.com

Ad on page 25

**Jet/Vac Combination Machines**



**U.S. SUBMERGENT TECHNOLOGIES**

**U.S. Submergent Technologies LLC**  
Sarasota, FL  
844-765-7866 • 941-444-1440 • Fax: 941-219-3080  
info@ussubmergent.com  
www.ussubmergent.com



**Jetters - Portable/Truck/ Trailers**

**Cam Spray**

Iowa Falls, IA  
800-648-5011 • 641-648-5011 • Fax: 641-648-5013  
sales@camspray.com  
www.camspray.com  
Ad on page 87

**Laboratory Equipment/ Supplies**

**CEM Corporation**

Matthews, NC  
800-726-3331 • Fax: 704-821-7015  
info@cem.com  
www.cem.com  
Ad on page 67

**CHEMetrics, Inc.**

Midland, VA  
800-356-3072 • 540-788-9026 • Fax: 540-788-4856  
sales@chemetrics.com  
www.chemetrics.com

**Hach**

Loveland, CO  
800-227-4224 • 970-669-3050  
orders@hach.com  
www.hach.com  
Ad on page 5

**HEMCO Corporation**

Independence, MO  
800-779-4362 • 816-796-2900 • Fax: 816-796-3333  
info@hemcocorp.com  
www.hemcocorp.com  
Ad on page 117

**International Products Corporation**

Burlington, NJ  
609-386-8770 • Fax: 609-386-8438  
mkt@ipcol.com  
www.ipcol.com

**LaMotte Company**

Chestertown, MD  
800-344-3100 • 410-778-3100 • Fax: 410-778-6394  
mkt@lamotte.com  
www.lamotte.com

**MoistTech Corp.**

Sarasota, FL  
941-351-7870  
www.moisttech.com/

**Nasco Whirl-Pak**

Fort Atkinson, WI  
800-558-9595 • 920-568-5578 • Fax: 920-568-5778  
info@enasco.com  
www.enasco.com/whirlpak  
Ad on page 117

**PolyScience**

Niles, IL  
800-229-7569 • 847-647-0611 • Fax: 847-647-1155  
sales@polyscience.com  
www.polyscience.com

**Sensorex**

Garden Grove, CA  
800-835-4344 • 714-895-4344  
sales@sensorex.com  
www.sensorex.com

**Van London Co.**

Houston, TX  
800-522-7920 • 832-456-6641 • Fax: 832-456-6642  
anna@vanlondon.com  
www.vanlondon.com

**Wako Chemicals USA, Inc.**

Richmond, VA  
877-714-1920 • 804-714-1920 • Fax: 804-271-7791  
www.wakousa.com

**Laboratory Services/ Testing**

**Activated Carbon Services - PACS**

Corapolis, PA  
800-367-2587 • 724-457-6576  
henry@pacslabs.com  
www.pacslabs.com

**Centrisys Corporation**

Kenosha, WI  
262-654-6006 • Fax: 262-764-8705  
info@centrisys.us  
www.centrisys.com  
Ad on page 81

**CNP-Technology Water and Biosolids Corp.**

Kenosha, WI  
262-764-3651 • Fax: 262-764-8705  
info@cnp-tec.com  
www.cnp-tec.com  
Ad on page 85

**Lagoon Ammonia Removal**



**Triplepoint Environmental**  
Oak Park, IL  
800-654-9307 • Fax: 312-957-4712  
info@triplepointwater.com  
www.tpev.com

**Lagoon Products**

**Aeration Industries International**

Chaska, MN  
800-328-8287 • 952-448-6789 • Fax: 952-448-7293  
air@aireo2.com  
www.aireo2.com

**Airmaster Aerator LLC**

DeRidder, LA  
888-813-3680 • 337-463-6567 • Fax: 337-463-9119  
deanc@airmasteraerator.com  
www.airmasteraerator.com  
Ad on page 4

**American Pleasure Products, Inc.**

Rose City, MI  
989-685-2697 • Fax: 989-685-8484  
info@aquacycleusa.com  
www.aquacycleusa.com  
Ad on page 77

**Do It Once!  
Do It Bright!**



Mobile Belt Filter Press with Operator Room  
Dewatering Solutions for Bio Solids, Sludge & Slurries

**Sales, Rentals,  
& Leasing Options**



Phone: 269-793-7183 Fax: 269-793-4022

127 N. Water St., Hopkins, MI 49328

www.brightbeltpress.com

FREE INFO - SEE ADVERTISER INDEX



**JDV LEVEL LODOR™**

**Design for Even Distribution  
&  
Odor Control**

www.jdvequipment.com



FREE INFO - SEE ADVERTISER INDEX



**Byo-Gon, Inc.**  
Charleston, SC  
888-796-4661 • 843-822-3415 • Fax: 843-606-6318  
info@bygogon.com  
www.byogon.com  
**Ad on page 117**

**Environetics, Inc.**  
Lockport, IL  
815-838-8331 • Fax: 815-838-8336  
info@environeticsinc.com  
www.environeticsinc.com

**Glasdon, Inc.**  
Sandston, VA  
855-874-5273 • 804-726-3777 • Fax: 804-726-3778  
inquiries@glasdon.com  
www.us.glasdon.com

**Greener Planet Systems**  
Monroe, IA  
888-669-1787 • 517-719-2580  
brianm@greenerplanetsystems.com  
www.greenerplanetsystems.com



**In-Pipe Technology**  
Wood Dale, IL  
888-325-5033 • 630-509-2488 • Fax: 630-509-2490  
jwilliams@in-pipe.com  
www.in-pipe.com

**LANXESS / International Dioxide, Inc.**  
North Kingstown, RI  
401-295-8800 • Fax: 401-295-7108  
adox@lanxess.com  
www.lanxess.com

**Mud Cat, Division of Ellicott Dredge Technologies**  
New Richmond, WI  
866-467-4010 • 913-642-5100 • Fax: 913-642-5119  
sales@mudcatdredge.com  
www.mudcatdredge.com

**RWL Water**  
Golden Valley, MN  
800-879-3677 • 763-746-8400 • Fax: 763-746-8408  
info@rwlwater.com  
www.rwlwater.com

**SRS Crisafulli, Inc.**  
Glendive, MT  
800-442-7867 • 406-365-3393 • Fax: 406-365-8088  
srsc@crisafulli.com  
www.crisafullipumps.com



**Triplepoint Environmental**  
Oak Park, IL  
800-654-9307 • Fax: 312-957-4712  
info@triplepointwater.com  
www.tpev.com

**Vaughan Company, Inc.**  
Montesano, WA  
888-249-2467 • 360-249-4042 • Fax: 360-249-6155  
info@chopperpumps.com  
www.chopperpumps.com  
**Ad on page 120**

## Leak Detection Equipment

**Analytical Technology, Inc.**  
Collegeville, PA  
800-959-0299 • 610-917-0991 • Fax: 610-917-0992  
sales@analyticaltechnology.com  
www.analyticaltechnology.com  
**Ad on page 118**

**Asahi/America, Inc.**  
Lawrence, MA  
800-343-3618 • 781-321-5409 • Fax: 800-787-6861  
asahi@asahi-america.com  
www.asahi-america.com

**Deep Trekker Inc.**  
Kitchener, ON  
Canada  
519-342-3177  
sales@deeptrekker.com  
www.deeptrekker.com  
**Ad on page 93**

**Emerson / Rosemount**  
Shakopee, MN  
800-854-8257 • 952-906-8888  
liquid.csc@emerson.com  
www.rosemount.com

**FCI - Fluid Components International**  
San Marcos, CA  
800-854-1993 • 760-744-6950 • Fax: 760-736-6250  
eflow@fluidcomponents.com  
www.fluidcomponents.com

**Hawk Measurement**  
Lawrence, MA  
888-429-5538 • 978-304-3000 • Fax: 978-304-1462  
info@hawkmeasure.com  
www.hawkmeasure.com

**Lutz-JESCO America Corp.**  
Rochester, NY  
800-554-2762 • 585-426-0990 • Fax: 585-426-4025  
mail@lutzjescoamerica.com  
www.lutzjescoamerica.com

**Peabody Engineering and Supply Inc.**  
Corona, CA  
877-734-3759 • Fax: 951-734-4111  
sales@4peabody.com  
www.4peabody.com

**Praxair, Inc.**  
Burr Ridge, IL  
800-772-9247 • 630-320-4000 • Fax: 630-320-4508  
info@praxair.com  
www.praxair.com/wastewater

**RKI Instruments, Inc.**  
Union City, CA  
800-754-5165 • 510-441-5656 • Fax: 510-441-5650  
orders@rkiinstruments.com  
www.rkiinstruments.com

**Sierra Instruments, Inc.**  
Monterey, CA  
800-866-0200 • 831-373-0200 • Fax: 831-373-4402  
info@sierrainstruments.com  
www.sierrainstruments.com

**U.S. Water Services Corporation**  
New Port Richey, FL  
866-753-8292 • 515-269-2336 • Fax: 727-848-7701  
info@uswatercorp.net  
www.uswatercorp.com

## Lift Stations/Wet Wells

**Data Flow Systems, Inc.**  
Melbourne, FL  
321-259-5009 • Fax: 321-259-4006  
info@dataflowsys.com  
www.dataflowsys.com

**F & V Operations and Resource Management**  
Grand Rapids, MI  
888-773-8806 • 616-588-2900 • Fax: 616-977-1005  
bselover@fv-operations.com  
www.fv-operations.com

**Greener Planet Systems**  
Monroe, IA  
888-669-1787 • 517-719-2580  
brianm@greenerplanetsystems.com  
www.greenerplanetsystems.com

**LANXESS / International Dioxide, Inc.**  
North Kingstown, RI  
401-295-8800 • Fax: 401-295-7108  
adox@lanxess.com  
www.lanxess.com

**Park Process**  
Houston, TX  
855-511-7275 • 713-849-7189 • Fax: 713-937-4254  
rcoughman@parkprocess.com  
www.parkprocess.com  
**Ad on page 116**

**Proco Products, Inc.**  
Stockton, CA  
800-344-3246 • 209-943-6088 • Fax: 209-943-0242  
sales@procoproducts.com  
www.procoproducts.com

**RWL Water**  
Golden Valley, MN  
800-879-3677 • 763-746-8400 • Fax: 763-746-8408  
info@rwlwater.com  
www.rwlwater.com

**Sewer Shield Composite LLC**  
Mesa, AZ  
480-830-9537  
info@sewershieldcomposites.com  
www.sewershieldcomposites.com



**Smith & Loveless, Inc.**  
Lenexa, KS  
800-898-9122 • 913-888-5201  
answers@smithandloveless.com  
www.smithandloveless.com

**Sunbelt Rentals**  
Fort Mill, SC  
800-736-2504  
www.sunbeltrentals.com  
**Ad on page 27**

**U.S. Water Services Corporation**  
New Port Richey, FL  
866-753-8292 • 515-269-2336 • Fax: 727-848-7701  
info@uswatercorp.net  
www.uswatercorp.com

**USP Technologies (US Peroxide)**  
Atlanta, GA  
877-346-4262 • 404-352-6070 • Fax: 404-352-6077  
info@uspstechnologies.com  
www.usptechnologies.com

**Vaughan Company, Inc.**  
Montesano, WA  
888-249-2467 • 360-249-4042 • Fax: 360-249-6155  
info@chopperpumps.com  
www.chopperpumps.com  
**Ad on page 120**

**Wastewater Depot, LLC**  
Batavia, OH  
513-732-0129 • Fax: 513-735-1485  
info@wastewaterdepot.com  
www.wastewaterdepot.com

## Lubricants

**International Products Corporation**  
Burlington, NJ  
609-386-8770 • Fax: 609-386-8438  
mkt@ipcol.com  
www.ipcol.com

## Maintenance/Operations Services



**Aqua Operations, Inc.**  
Bakersfield, CA  
888-746-6535 • 661-331-1181 • Fax: 661-833-1861  
childerbrand@aquaooperations.com  
www.aquaooperations.com

## Endress+Hauser

**Endress+Hauser**  
Greenwood, IN  
888-363-7377 • Fax: 317-535-8498  
info@us.endress.com  
www.us.endress.com

**F & V Operations and Resource Management**  
Grand Rapids, MI  
888-773-8806 • 616-588-2900 • Fax: 616-977-1005  
bselover@fv-operations.com  
www.fv-operations.com

## Manhole Rehabilitation

**Environmental Coatings LLC**  
Mesa, AZ  
480-984-7608  
info@sewershield.com  
www.sewershield.com

**JPCI Services**  
Mesa, AZ  
480-986-1212  
info@ipciservices.com  
www.ipciservices.com

**Sewer Shield Composite LLC**  
Mesa, AZ  
480-830-9537  
info@sewershieldcomposites.com  
www.sewershieldcomposites.com



**MBBR/IFAS**

**Headworks International, Inc.**  
Houston, TX  
713-647-6667 • Fax: 713-647-0999  
hw@headworksintl.com  
www.headworksintl.com

**Membrane Bioreactors (MBR)**

**Alfa Laval Inc.**  
Richmond, VA  
866-253-2528  
customerservice.usa@alfalaval.com  
www.alfalaval.us

**Aqua Operations, Inc.**  
Bakersfield, CA  
888-746-6535 • 661-331-1181 • Fax: 661-833-1861  
childerbrand@aquaoptions.com  
www.aquaoptions.com

**Aqua-Aerobic Systems, Inc.**  
Loves Park, IL  
800-940-5008 • 815-654-2501 • Fax: 815-654-2508  
solutions@aquaaerobic.com  
www.aqua-aerobic.com  
**Ad on page 11**

**Bio-Microbics, Inc.**  
Shawnee, KS  
800-753-3278 • 913-422-0707 • Fax: 913-422-0808  
sales@biomicrobics.com  
www.biomicrobics.com

**Enterprise Specialty Products**  
Laurens, SC  
864-984-7700 • Fax: 864-984-2241  
www.enterprisesp.com

**Evoqua Water Technologies LLC**  
Warrendale, PA  
800-466-7873 • 724-772-0044  
municipalmarketing@evoqua.com  
www.evoqua.com

**Huber Technology, Inc.**  
Huntersville, NC  
704-949-1010 • Fax: 704-949-1020  
marketing@hhusa.net  
www.huberforum.net  
**Ad on page 9**



**Ovivo USA, LLC**  
Austin, TX  
512-834-6000 • Fax: 512-834-6039  
info.us@ovivowater.com  
www.ovivowater.com



**Premier Tech Aqua**  
Riviere-du-Loup, QC  
Canada  
800-632-6356 • 418-867-8883 • Fax: 418-862-6642  
pta@premiertech.com  
www.premiertechaqua.com



**Smith & Loveless, Inc.**  
Lenexa, KS  
800-898-9122 • 913-888-5201  
answers@smithandloveless.com  
www.smithandloveless.com

**Membranes - Microfiltration**

**Graver Technologies**  
Glasgow, DE  
302-731-1700 • Fax: 302-369-0938  
info@gravertech.com  
www.gravertech.com

**Membranes - Ultrafiltration**

**AQUA-AEROBIC SYSTEMS, INC.**  
**Aqua-Aerobic Systems, Inc.**  
Loves Park, IL  
800-940-5008 • 815-654-2501 • Fax: 815-654-2508  
solutions@aquaaerobic.com  
www.aqua-aerobic.com  
**Ad on page 11**

**International Products Corporation**  
Burlington, NJ  
609-386-8770 • Fax: 609-386-8438  
mkt@ipcol.com  
www.ipcol.com

**Westech Engineering**  
Salt Lake City, UT  
801-265-1000 • Fax: 801-265-1080  
info@westech-inc.com  
www.westech-inc.com

**Meters**

**Blue-White Industries**  
Huntington Beach, CA  
714-893-8529 • Fax: 714-894-9492  
sales@blue-white.com  
www.blue-white.com  
**Ad on page 2**

**Cla-Val**  
Costa Mesa, CA  
800-942-6326 • 949-722-4800 • Fax: 949-574-5703  
info@cla-val.com  
www.cla-val.com



**Delta M Corporation**  
Oak Ridge, TN  
800-922-0083 • 865-483-1569 • Fax: 865-483-1142  
sales@deltamcorp.com  
www.deltamcorp.com

**ElectroSwitch Corporation**  
Weymouth, MA  
781-335-5200  
info@electroswitch.com  
www.electroswitch.com

Convert Your Mobile Device into a HART Communicator ... with our Advanced HART-based Products

**Get HART® Data...On the Go!**

CONNECT → CONFIGURE → DOCUMENT

- DevComDroid Communicator App**  
Full DD access to HART instruments using your Android device
- DevCom2000 Communicator Software**  
Full DD access to HART instruments using your Windows device
- HART Modems (Interface Hardware)**  
Bluetooth, USB and RS232 models

**PROCOMSOL**  
Process Communications Solutions  
www.procomsol.com

Call Us: 216.221.1550  
or toll free: 877.221.1551  
Fax: 216.221.1554  
Email: sales@procomsol.com

HART COMMUNICATIONS TECHNOLOGY    WirelessHART    HART-IP

FREE INFO – SEE ADVERTISER INDEX

**CalPrex™**  
Pre-Digestion Phosphorus Recovery Technology

**THE PROBLEM**  
Phosphorus solubilization limits recovery efficiency.

**THE SOLUTION**  
Acid phase digestion: the biological solution for P solubilization.

**THE BENEFITS**  
Reduce up to **50%** of the total P in dewatered biosolids.

**CNP**  
CARBON | NITROGEN | PHOSPHORUS  
A division of Centrisys Corporation

Discover more at [CNP-Tec.com/CalPrex](http://CNP-Tec.com/CalPrex)

FREE INFO – SEE ADVERTISER INDEX

## Endress+Hauser

**Endress+Hauser**  
Greenwood, IN  
888-363-7377 • Fax: 317-535-8498  
info@us.endress.com  
www.us.endress.com

**FCI - Fluid Components International**  
San Marcos, CA  
800-854-1993 • 760-744-6950 • Fax: 760-736-6250  
eflow@fluidcomponents.com  
www.fluidcomponents.com

**Hach**  
Loveland, CO  
800-227-4224 • 970-669-3050  
orders@hach.com  
www.hach.com

**Ad on page 5**

**Hawk Measurement**  
Lawrence, MA  
888-429-5538 • 978-304-3000 • Fax: 978-304-1462  
info@hawkmeasure.com  
www.hawkmeasure.com

**LaMotte Company**  
Chestertown, MD  
800-344-3100 • 410-778-3100 • Fax: 410-778-6394  
mkt@lamotte.com  
www.lamotte.com

**McCrometer Inc.**  
Hemet, CA  
800-220-2279 • 951-652-6811 • Fax: 951-652-3078  
customerservice@mccrometer.com  
www.mccrometer.com

**Red Meters**  
Orlando, FL  
407-337-0110  
hello@redmeters.com  
www.redmeters.com

**Ad on page 116**

**Sierra Instruments, Inc.**  
Monterey, CA  
800-866-0200 • 831-373-0200 • Fax: 831-373-4402  
info@sierrainstruments.com  
www.sierrainstruments.com

**Sure Flow Products, LLC**  
Wixom, MI  
248-380-3569 • Fax: 248-380-3568  
sales@sureflowproducts.com  
www.flowmetersource.com

**Van London Co.**  
Houston, TX  
800-522-7920 • 832-456-6641 • Fax: 832-456-6642  
anna@vanlondon.com  
www.vanlondon.com

## Mixers

**Aeration Industries International**  
Chaska, MN  
800-328-8287 • 952-448-6789 • Fax: 952-448-7293  
aii@aireo2.com  
www.aireo2.com

**Airmaster Aerator LLC**  
DeRidder, LA  
888-813-3680 • 337-463-6567 • Fax: 337-463-9119  
deanc@airmasteraerator.com  
www.airmasteraerator.com

**Ad on page 4**

**Aqua-Aerobic Systems, Inc.**  
Loves Park, IL  
800-940-5008 • 815-654-2501 • Fax: 815-654-2508  
solutions@aquaaerobic.com  
www.aquaaerobic.com

**Ad on page 11**

**AQUATURBO SYSTEMS, Inc.**  
Springdale, AR  
479-927-1300 • Fax: 479-927-0700  
ats@aquaturbo.com  
www.aquaturbousa.com

**Bradley Innovation Group**  
Indianapolis, IN  
317-726-6615  
sales@big-h2o.com  
www.big-h2o.com

**Fluidyne Corporation**  
Cedar Falls, IA  
319-266-9967 • Fax: 319-277-6034  
fluidyne@fluidynecorp.com  
www.fluidynecorp.com

**JDV Equipment Corporation**  
Dover, NJ  
973-366-6556 • Fax: 973-366-3193  
sales@jdvequipment.com  
www.jdvequipment.com

**KSB, Inc.**  
Henrico, VA  
800-945-7867 • 804-222-1818 • Fax: 804-226-6961  
sales@ksbusa.com  
www.ksbusa.com

**Kuhn North America, Inc.**  
Brookfield, WI  
608-897-2131 • Fax: 608-897-2561  
chris.searles@kuhn.com  
www.kuhnnorthamerica.com

**Ad on page 8**

**Ovivo USA, LLC**  
Austin, TX  
512-834-6000 • Fax: 512-834-6039  
info.us@ovivowater.com  
www.ovivowater.com

**Philadelphia Gear - A Timken Brand**  
King of Prussia, PA  
800-766-5120 • 610-265-3000 • Fax: 610-337-5637  
info@philagear.com  
www.philagear.com

**Pick Heaters, Inc.**  
West Bend, WI  
262-338-1191 • Fax: 262-338-8489  
info1@pickheaters.com  
www.pickheaters.com

**Praxair, Inc.**  
Burr Ridge, IL  
800-772-9247 • 630-320-4000 • Fax: 630-320-4508  
info@praxair.com  
www.praxair.com/wastewater

**ProMinent Fluid Controls, Inc.**  
Pittsburgh, PA  
412-787-2484 • Fax: 412-787-0704  
sales@prominent.us  
www.prominent.us

**Pulsed Hydraulics, Inc.**  
Oroville, WA  
800-641-1726 • 425-785-3225  
info@phiwater.com  
www.phiwater.com

**Ad on page 116**

**Rebuild-It Service Group, LLC**  
Midvale, UT  
888-709-5676 • Fax: 385-355-6989  
treburn@rebuild-it.com  
www.rebuild-it.com

**RWL Water**  
Golden Valley, MN  
800-879-3677 • 763-746-8400 • Fax: 763-746-8408  
info@rwlwater.com  
www.rwlwater.com

**Sulzer Pumps Solutions Inc.**  
Meriden, CT  
800-525-7790 • 203-238-2700 • Fax: 203-238-0738  
info.abs.usa@sulzer.com  
www.sulzer.com

**Vaughan Company, Inc.**  
Montesano, WA  
888-249-2467 • 360-249-4042 • Fax: 360-249-6155  
info@chopperpumps.com  
www.chopperpumps.com

**Ad on page 120**

## Moisture Analyzers

**MoistTech Corp.**  
1199 Tallevast Rd.  
Sarasota, FL 34243  
941-351-7870  
www.moisttech.com

## Monitoring Equipment

**Analytical Technology, Inc.**  
Collegeville, PA  
800-959-0299 • 610-917-0991 • Fax: 610-917-0992  
sales@analyticaltechnology.com  
www.analyticaltechnology.com

**Ad on page 118**

**ASA Analytics**  
Waukesha, WI  
262-717-9500 • Fax: 262-717-9530  
info@chemscan.com  
www.asaanalytics.com

**BinMaster Level Controls**  
Lincoln, NE  
800-278-4241 • 402-434-9102 • Fax: 402-434-9133  
info@binmaster.com  
www.binmaster.com

**CHEMetrics, Inc.**  
Midland, VA  
800-356-3072 • 540-788-9026 • Fax: 540-788-4856  
sales@chemetrics.com  
www.chemetrics.com

**Data Flow Systems, Inc.**  
Melbourne, FL  
321-259-5009 • Fax: 321-259-4006  
info@dataflowsys.com  
www.dataflowsys.com

**Deep Trekker Inc.**  
Kitchener, ON  
Canada  
519-342-3177  
sales@deeptrekker.com  
www.deeptrekker.com

**Ad on page 93**



**Delta M Corporation**  
Oak Ridge, TN  
800-922-0083 • 865-483-1569 • Fax: 865-483-1142  
sales@deltamcorp.com  
www.deltamcorp.com

**ElectroSwitch Corporation**  
Weymouth, MA  
781-335-5200  
info@electroswitch.com  
www.electroswitch.com

**Emerson / Rosemount**  
Shakopee, MN  
800-854-8257 • 952-906-8888  
liquid.csc@emerson.com  
www.rosemount.com

**Emerson Automation Solutions**  
Pittsburgh, PA  
800-445-9723 • 412-963-4000  
powerwater@emerson.com  
www.emerson.com/water

**EnviroSuite**  
Burlingame, CA  
424-335-1331  
inquiries@envirosuite.com  
www.envirosuite.com

**FCI - Fluid Components International**  
San Marcos, CA  
800-854-1993 • 760-744-6950 • Fax: 760-736-6250  
eflow@fluidcomponents.com  
www.fluidcomponents.com

**Force Flow**  
Concord, CA  
800-893-6723 • 925-686-6700 • Fax: 925-686-6713  
info@forceflow.com  
www.forceflow.com

**Hawk Measurement**  
Lawrence, MA  
888-429-5538 • 978-304-3000 • Fax: 978-304-1462  
info@hawkmeasure.com  
www.hawkmeasure.com

**Howden Roots**  
Connersville, IN  
800-557-6687 • 765-827-9200 • Fax: 765-827-9317  
connersville.customercare@howden.com  
www.howdenroots.com

**Industrial Scientific**  
Pittsburgh, PA  
412-788-4353 • Fax: 412-788-8353  
info@indsci.com  
www.indsci.com

**IWAKI America**  
Holliston, MA  
508-429-1440  
info@iwakiamerica.com  
www.iwakiamerica.com

**Keller America Inc.**  
Newport News, VA  
877-253-5537 • 757-596-6680 • Fax: 757-596-6659  
sales@kelleramerica.com  
www.kelleramerica.com

**Ad on page 7**



**LaMotte Company**  
 Chestertown, MD  
 800-344-3100 • 410-778-3100 • Fax: 410-778-6394  
 mkt@lamotte.com  
 www.lamotte.com

**McCrometer Inc.**  
 Hemet, CA  
 800-220-2279 • 951-652-6811 • Fax: 951-652-3078  
 customerservice@mccrometer.com  
 www.mccrometer.com

**MoistTech Corp.**  
 Sarasota, FL  
 941-351-7870  
 www.moisttech.com/

**MYRON L COMPANY**  
**Myron L Company**  
 Carlsbad, CA  
 760-438-2021 • Fax: 760-931-9189  
 info@myronl.com  
 www.myronl.com  
 Ad on page 57

**Nasco Whirl-Pak**  
 Fort Atkinson, WI  
 800-558-9595 • 920-568-5578 • Fax: 920-568-5778  
 info@enasco.com  
 www.enasco.com/whirlpak  
 Ad on page 117

**Peabody Engineering and Supply Inc.**  
 Corona, CA  
 877-734-3759 • Fax: 951-734-4111  
 sales@4peabody.com  
 www.4peabody.com

**Phoenix Contact**  
 Middletown, PA  
 800-888-7388 • 717-944-1300  
 info@phoenixcon.com  
 www.phoenixcontact.com/usa\_home

**PMC Engineering**  
 Danbury, CT  
 203-792-8686 • Fax: 203-743-2051  
 sales@pmc1.com  
 www.pmc1.com

**PRIMEX**  
 Detroit Lakes, MN  
 888-342-5753 • 218-847-1317 • Fax: 218-847-4617  
 info@primexcontrols.com  
 www.primexcontrols.com

**RKI Instruments, Inc.**  
 Union City, CA  
 800-754-5165 • 510-441-5656 • Fax: 510-441-5650  
 orders@rkiinstruments.com  
 www.rkiinstruments.com

**Sensaphone**  
 Aston, PA  
 877-373-2700 • 610-558-2700 • Fax: 610-558-0222  
 contact@sensaphone.com  
 www.sensaphone.com

**Sierra Instruments, Inc.**  
 Monterey, CA  
 800-866-0200 • 831-373-0200 • Fax: 831-373-4402  
 info@sierrainstruments.com  
 www.sierrainstruments.com

**Sunbelt Rentals**  
 Fort Mill, SC  
 800-736-2504  
 www.sunbeltrentals.com  
 Ad on page 27

**Sure Flow Products, LLC**  
 Wixom, MI  
 248-380-3569 • Fax: 248-380-3568  
 sales@sureflowproducts.com  
 www.flowmetersource.com

**Trihedral Engineering Limited**  
 Bedford, NS  
 Canada  
 800-463-2783 • 902-835-1575 • Fax: 902-835-0369  
 pcooke@trihedral.com  
 www.trihedral.com

**Weidmüller**



**Weidmüller**  
 Richmond, VA  
 800-849-9343 • Fax: 804-379-2593  
 info@weidmuller.com  
 www.weidmuller.com

**Motors & Motor Controls**

**Philadelphia Gear - A Timken Brand**  
 King of Prussia, PA  
 800-766-5120 • 610-265-3000 • Fax: 610-337-5637  
 info@philagear.com  
 www.philagear.com

**Phoenix Contact**  
 Middletown, PA  
 800-888-7388 • 717-944-1300  
 info@phoenixcon.com  
 www.phoenixcontact.com/usa\_home

**Ronk Electrical**  
 Nokomis, IL  
 800-221-7665 • 217-563-8333 • Fax: 217-563-8336  
 sales@ronkelectrical.com  
 www.ronkelectrical.com  
 Ad on page 116

**Sierra Environmental Technologies, LLC**  
 Wildwood, MO  
 636-273-5189 • Fax: 636-273-4509  
 dnokes@setodorcontrol.com  
 www.setodorcontrol.com

**WEG Electric Corp**  
 Duluth, GA  
 800-275-4934  
 info-us@weg.net  
 www.weg.net/us

**Nutrient Removal**

**Aeration Industries International**  
 Chaska, MN  
 800-328-8287 • 952-448-6789 • Fax: 952-448-7293  
 aii@aireo2.com  
 www.aireo2.com

Working Well Under Pressure  
**CAM SPRAY**

**Pressure Washers & Drain Jetting Equipment**

**Hot and Cold Trailer Models**  
 Up to 7000 psi  
 Flows up to 40 gpm  
 Powered Reels  
 Diesel Powered Models



**Skid and truck mount models up to 7000 psi**





**Portable Hot and Cold Water Diesel Powered Models**



**We will custom build to your specifications**  
 www.camspray.com 800-648-5011

FREE INFO - SEE ADVERTISER INDEX

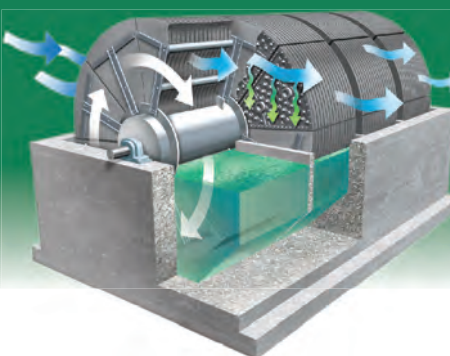
**EnviroDisc®**  
**Rotating Biological Contactor**  
**Lowest Installed Energy For the Right Process**



- Low Energy, Low Maintenance.
- Longest Successful Operating History of any RBC manufactured today.
- Used for Municipal, Industrial and Land Development Applications.

**WALKER PROCESS EQUIPMENT**  
 Walker Process Equipment  
 www.walker-process.com



FREE INFO - SEE ADVERTISER INDEX

**Airmaster Aerator LLC**

DeRidder, LA  
888-813-3680 • 337-463-6567 • Fax: 337-463-9119  
deanc@airmasteraerator.com  
www.airmasteraerator.com

Ad on page 4

**Aqua Operations, Inc.**

Bakersfield, CA  
888-746-6535 • 661-331-1181 • Fax: 661-833-1861  
childerbrand@aquaooperations.com  
www.aquaooperations.com

**Aqua-Aerobic Systems, Inc.**

Loves Park, IL  
800-940-5008 • 815-654-2501 • Fax: 815-654-2508  
solutions@aquaaerobic.com  
www.aquaaerobic.com

Ad on page 11

**ASA Analytics**

Waukesha, WI  
262-717-9500 • Fax: 262-717-9530  
info@chemscan.com  
www.asaanalytics.com

**BCR Environmental Corporation**

Jacksonville, FL  
904-819-9170 • Fax: 904-998-3828  
marketing@bcrenv.com  
www.bcrenv.com

**CNP-Technology Water and Biosolids Corp.**

Kenosha, WI  
262-764-3651 • Fax: 262-764-8705  
info@cnp-tec.com  
www.cnp-tec.com

Ad on page 85

**Environetics, Inc.**

Lockport, IL  
815-838-8331 • Fax: 815-838-8336  
info@environeticsinc.com  
www.environeticsinc.com

**Evoqua Water Technologies LLC**

Warrendale, PA  
800-466-7873 • 724-772-0044  
municipalmarketing@evoqua.com  
www.evoqua.com

**Fluidyne Corporation**

Cedar Falls, IA  
319-266-9967 • Fax: 319-277-6034  
fluidyne@fluidynecorp.com  
www.fluidynecorp.com

**Ford Hall Company, Inc.**

Richmond, KY  
859-624-1077 • Fax: 859-624-3320  
sperry@fordhall.com  
www.weir-wolf.com

Ad on page 79



**GEA Group**

Northvale, NJ  
800-722-6622 • 201-767-3900 • Fax: 201-767-3901  
info.wsus@gea.com  
www.gea.com

**Hach**

Loveland, CO  
800-227-4224 • 970-669-3050  
orders@hach.com  
www.hach.com

Ad on page 5

**Headworks International, Inc.**

Houston, TX  
713-647-6667 • Fax: 713-647-0999  
hw@headworksintl.com  
www.headworksintl.com

**Ovivo USA, LLC**

Austin, TX  
512-834-6000 • Fax: 512-834-6039  
info.us@ovivowater.com  
www.ovivowater.com

**Parkson Corporation**

Ft. Lauderdale, FL  
888-727-5766 • Fax: 954-974-6182  
technology@parkson.com  
www.parkson.com

**PRD Tech, Inc.**  
Cincinnati, OH  
513-673-3583  
rgovind837@aol.com  
www.prdtechinc.com

**RWL Water**

Golden Valley, MN  
800-879-3677 • 763-746-8400 • Fax: 763-746-8408  
info@rwlwater.com  
www.rwlwater.com

**Schwing Bioset, Inc.**

Somerset, WI  
844-246-7381 • 715-247-3433 • Fax: 715-247-3438  
marketing@schwingbioset.com  
www.schwingbioset.com

**Triplepoint Environmental**

Oak Park, IL  
800-654-9307 • Fax: 312-957-4712  
info@triplepointwater.com  
www.tpev.com

**USALCO, LLC**

Baltimore, MD  
800-882-3883 • 410-918-2230  
ctesone@usalco.com  
www.usalco.com  
Ad on page 81

**USP Technologies (US Peroxide)**

Atlanta, GA  
877-346-4262 • 404-352-6070 • Fax: 404-352-6077  
info@usp technologies.com  
www.usptechnologies.com

**Odor Control Products/  
Equipment**

**Activated Carbon Services - PACS**

Coraopolis, PA  
800-367-2587 • 724-457-6576  
henry@pacslabs.com  
www.pacslabs.com

**AdEdge Water Technologies, LLC**

Duluth, GA  
866-823-3343 • 678-835-0052 • Fax: 678-835-0057  
sales@adedgetechnologies.com  
www.adedgetech.com

Ad on page 25

**Aeration Industries International**

Chaska, MN  
800-328-8287 • 952-448-6789 • Fax: 952-448-7293  
aii@aireo2.com  
www.aireo2.com

**Airmaster Aerator LLC**

DeRidder, LA  
888-813-3680 • 337-463-6567 • Fax: 337-463-9119  
deanc@airmasteraerator.com  
www.airmasteraerator.com

Ad on page 4

**Anue Water Technologies, Inc.**  
Oceanside, CA  
760-727-2683  
info@anuewater.com  
www.anuewater.com

**BCR Environmental Corporation**

Jacksonville, FL  
904-819-9170 • Fax: 904-998-3828  
marketing@bcrenv.com  
www.bcrenv.com

**BioAir Solutions LLC**

Voorhees, NJ  
856-258-6969 • Fax: 856-258-6975  
cwest@bioairsolutions.com  
www.bioairsolutions.com

**Bionetix International**

Ste-Anne-de-Bellevue, QC  
Canada  
514-457-2914 • Fax: 514-457-3589  
info@bionetix.ca  
www.bionetix-international.com

**BOHN BIOFILTER®  
Odor and Air Emissions Control**

**BOHN BIOFILTER**

Tucson, AZ  
520-624-4644  
info@bohnbiofilter.com  
www.bohnbiofilter.com

**Byo-Gon, Inc.**

Charleston, SC  
888-796-4661 • 843-822-3415 • Fax: 843-606-6318  
info@byogon.com  
www.byogon.com  
Ad on page 117

**CEI - Carbon Enterprises Inc.**

Circleville, OH  
800-344-5770 • Fax: 888-204-9656  
info@ceicompanies.com  
www.ceifiltration.com

**CST Industries, Inc.**

Kansas City, MO  
913-621-3700  
sales@cstindustries.com  
www.cstindustries.com

**Environetics, Inc.**

Lockport, IL  
815-838-8331 • Fax: 815-838-8336  
info@environeticsinc.com  
www.environeticsinc.com

**EnviroSuite**

Burlingame, CA  
424-335-1331  
inquiries@envirosuite.com  
www.envirosuite.com

**Evoqua Water Technologies LLC**

Warrendale, PA  
800-466-7873 • 724-772-0044  
municipalmarketing@evoqua.com  
www.evoqua.com

**Fibergrate Composite Structures**

Dallas, TX  
800-527-4043 • 972-250-1633 • Fax: 972-250-1530  
info@fibergrate.com  
www.fibergrate.com

**Ford Hall Company, Inc.**

Richmond, KY  
859-624-1077 • Fax: 859-624-3320  
sperry@fordhall.com  
www.weir-wolf.com

Ad on page 79



**Geomembrane Technologies Inc.**

Fredericton, NB  
Canada  
855-484-4630 • 506-452-7304 • Fax: 506-452-6625  
covers@gticovers.com  
www.gticovers.com

**GillTrading.com, Inc./WeirWasher, ACS**

Beaverton, OR  
866-447-2496 • 503-628-0197 • Fax: 503-646-9293  
brentgill@gilltrading.com  
www.gilltrading.com

**Greener Planet Systems**

Monroe, LA  
888-669-1787 • 517-719-2580  
briam@greenerplanetsystems.com  
www.greenerplanetsystems.com

**HEMCO Corporation**

Independence, MO  
800-779-4362 • 816-796-2900 • Fax: 816-796-3333  
info@hemcocorp.com  
www.hemcocorp.com  
Ad on page 117

**Hydrite Chemical Co.**

Brookfield, WI  
262-792-1450  
marketing@hydrite.com  
www.hydrite.com



**In-Pipe Technology**

Wood Dale, IL  
888-325-5033 • 630-509-2488 • Fax: 630-509-2490  
jwilliams@in-pipe.com  
www.in-pipe.com

**INDUSCO  
ENVIRONMENTAL**

**Indusco Environmental Services, Inc.**

Spanish Fort, AL  
251-621-2338  
sales@induscoenviro.com  
www.induscoenviro.com



**JDV Equipment Corporation**

Dover, NJ  
973-366-6556 • Fax: 973-366-3193  
sales@jdvequipment.com  
www.jdvequipment.com

Ad on page 83

**KCH Engineered Systems**

Forest City, NC  
828-245-9836  
khankinson@kchservices.com  
www.kchservices.com

**LANXESS / International Dioxide, Inc.**

North Kingstown, RI  
401-295-8800 • Fax: 401-295-7108  
adox@lanxess.com  
www.lanxess.com

**NEFCO Systems, Inc.**

Palm Beach Gardens, FL  
561-775-9303 • Fax: 561-775-6043  
sales@nefco.us  
www.nefco.us

**OMI Industries**

Long Grove, IL  
800-662-6367 • Fax: 847-304-0989  
www.omi-industries.com



**Oxbow Activated Carbon LLC**  
Oceanside, CA  
760-630-5724 • Fax: 760-630-9930  
sales@oxbowactivatedcarbon.com  
www.oxbowactivatedcarbon.com

**Paxxo**

Newnan, GA  
770-502-0055 • Fax: 770-502-0088  
chris.pettigrew@paxxo.com  
www.paxxo.com

**Permastore**

Suffolk  
England  
011 44 1379870723  
sales@permastore.com  
www.permastore.com

**Praxair, Inc.**

Burr Ridge, IL  
800-772-9247 • 630-320-4000 • Fax: 630-320-4508  
info@praxair.com  
www.praxair.com/wastewater

**Proco Products, Inc.**

Stockton, CA  
800-344-3246 • 209-943-6088 • Fax: 209-943-0242  
sales@procoproducts.com  
www.procoproducts.com

**Pulsed Hydraulics, Inc.**

Oroville, WA  
800-641-1726 • 425-785-3225  
info@phiwater.com  
www.phiwater.com

Ad on page 116

**Sierra Environmental Technologies, LLC**

Wildwood, MO  
636-273-5189 • Fax: 636-273-4509  
dnokes@setodorcontrol.com  
www.setodorcontrol.com

**Simple Solutions Distributing**

West Milford, NJ  
866-667-8465 • 973-846-7817 • Fax: 973-858-0219  
sales@industrialodorcontrol.com  
www.IndustrialOdorControl.com

Ad on page 116

**USP Technologies (US Peroxide)**

Atlanta, GA  
877-346-4262 • 404-352-6070 • Fax: 404-352-6077  
info@usp technologies.com  
www.usptechnologies.com

**VaraCorp LLC**

Wimberley, TX  
800-801-6685 • 512-847-5026 • Fax: 866-611-6703  
info@varacorp.com  
www.varacorp.com

**Watson-Marlow Fluid Technology Group**

Wilmington, MA  
800-282-8823 • 978-658-6168 • Fax: 978-658-0041  
support@wmpg.us  
www.watson-marlow.com

Ad on page 53

**Onsite Generation -  
Cl<sub>2</sub> + NaOCl**

**Electrolytic Technologies LLC**

North Miami Beach, FL  
305-655-2755 • Fax: 305-655-2669  
info@electrolytictech.com  
www.electrolytictech.com

Ad on page 116

**Oxidation Ditches**

**Aeration Industries International**

Chaska, MN  
800-328-8287 • 952-448-6789 • Fax: 952-448-7293  
aai@aireo2.com  
www.aireo2.com

**Airmaster Aerator LLC**

DeRidder, LA  
888-813-3680 • 337-463-6567 • Fax: 337-463-9119  
deanc@airmasteraerator.com  
www.airmasteraerator.com

Ad on page 4

**Aqua Operations, Inc.**

Bakersfield, CA  
888-746-6535 • 661-331-1181 • Fax: 661-833-1861  
childerbrand@aquaoptions.com  
www.aquaoptions.com

**Evoqua Water Technologies LLC**

Warrendale, PA  
800-466-7873 • 724-772-0044  
municipalmarketing@evoqua.com  
www.evoqua.com

**F & V Operations and Resource Management**

Grand Rapids, MI  
888-773-8806 • 616-588-2900 • Fax: 616-977-1005  
bselover@fv-operations.com  
www.fv-operations.com

**Fluidyne Corporation**

Cedar Falls, IA  
319-266-9967 • Fax: 319-277-6034  
fluidyne@fluidynecorp.com  
www.fluidynecorp.com

**SpillSafeLX™ Electronic Drum Scale**

**Monitor Chemicals and  
Control Spills!**



Wizard 4000®  
Weight Indicator



- ◆ Safely track chemical usage and tank level
- ◆ Complies with EPA containment regulation 40 CFR 264.175
- ◆ Contains spills and leaks



For more information,  
Call (925) 686-6700 or  
visit [www.forceflow.com](http://www.forceflow.com)

FREE INFO – SEE ADVERTISER INDEX

**GAR-DUR®**

**UHMW POLYETHYLENE**

**WEAR RAILS  
SPROCKETS  
WEAR SHOES**



**Garland Manufacturing Company**

ESTABLISHED 1866

55 Industrial Park Road • P.O. Box 538 • Saco ME 04072  
Phone: 207-283-3693 • Toll-Free: 800-727-1900 • Fax: 207-283-4834  
Email: [wastewater@garlandmfg.com](mailto:wastewater@garlandmfg.com)

<http://www.garlandmfg.com/plastics/wastewater.html>

FREE INFO – SEE ADVERTISER INDEX



Cleaner Water for a Brighter Future®

**Lakeside Equipment Corporation**

Bartlett, IL  
630-837-5640 • Fax: 630-837-5647  
sales@lakeside-equipment.com  
www.lakeside-equipment.com

Ad on page 3



**Ovivo USA, LLC**  
Austin, TX  
512-834-6000 • Fax: 512-834-6039  
info.us@ovivowater.com  
www.ovivowater.com

**RWL Water**  
Golden Valley, MN  
800-879-3677 • 763-746-8400 • Fax: 763-746-8408  
info@rwlwater.com  
www.rwlwater.com



**Westech Engineering**  
Salt Lake City, UT  
801-265-1000 • Fax: 801-265-1080  
info@westech-inc.com  
www.westech-inc.com

**Ozonation Equipment/  
Systems**



**Anue Water Technologies, Inc.**  
Oceanside, CA  
760-727-2683  
info@anuewater.com  
www.anuewater.com

**Aqua-Aerobic Systems, Inc.**  
Loves Park, IL  
800-940-5008 • 815-654-2501 • Fax: 815-654-2508  
solutions@aquaaerobic.com  
www.aquaaerobic.com

Ad on page 11

**Praxair, Inc.**  
Burr Ridge, IL  
800-772-9247 • 630-320-4000 • Fax: 630-320-4508  
info@praxair.com  
www.praxair.com/wastewater

**Package Treatment Plants**

**Alfa Laval Inc.**  
Richmond, VA  
866-253-2528  
customerservice.usa@alfalaval.com  
www.alfalaval.us

**Electrolytic Technologies LLC**  
North Miami Beach, FL  
305-655-2755 • Fax: 305-655-2669  
info@electrolytictech.com  
www.electrolytictech.com

Ad on page 116

**RWL Water**  
Golden Valley, MN  
800-879-3677 • 763-746-8400 • Fax: 763-746-8408  
info@rwlwater.com  
www.rwlwater.com

**Pest Control**



**Central Life Sciences**  
Schaumburg, IL  
800-367-0659  
conrel@central.com  
www.strikeproducts.com

Ad on page 17

**Phase Converters**

**Ronk Electrical**  
Nokomis, IL  
800-221-7665 • 217-563-8333 • Fax: 217-563-8336  
sales@ronkelectrical.com  
www.ronkelectrical.com

Ad on page 116

**Pipe**

**Agru America, Inc.**  
Georgetown, SC  
800-373-2478 • 843-546-0600 • Fax: 843-527-2738  
salesmk@agruamerica.com  
www.agruamerica.com

**Asahi/America, Inc.**  
Lawrence, MA  
800-343-3618 • 781-321-5409 • Fax: 800-787-6861  
asahi@asahi-america.com  
www.asahi-america.com

**Rain for Rent**  
Bakersfield, CA  
800-742-7246 • 661-399-9124  
info@rainforrent.com  
www.rainforrent.com

**Sunbelt Rentals**  
Fort Mill, SC  
800-736-2504  
www.sunbeltrentals.com

Ad on page 27

**Pipe Cleaning/Inspection**

**Deep Trekker Inc.**  
Kitchener, ON  
Canada  
519-342-3177  
sales@deeptrekker.com  
www.deeptrekker.com

Ad on page 93

**Mud Cat, Division of Ellicott Dredge Technologies**  
New Richmond, WI  
866-467-4010 • 913-642-5100 • Fax: 913-642-5119  
sales@mudcatdredge.com  
www.mudcatdredge.com

**Praxair, Inc.**  
Burr Ridge, IL  
800-772-9247 • 630-320-4000 • Fax: 630-320-4508  
info@praxair.com  
www.praxair.com/wastewater

**U.S. Submergent Technologies LLC**  
Sarasota, FL  
844-765-7866 • 941-444-1440 • Fax: 941-219-3080  
info@ussubmergent.com  
www.ussubmergent.com

**Polymers**

**Aqua Operations, Inc.**  
Bakersfield, CA  
888-746-6535 • 661-331-1181 • Fax: 661-833-1861  
childerbrand@aquaoptions.com  
www.aquaoptions.com

**Boerger, LLC**  
Chanhassen, MN  
612-435-7300 • Fax: 612-435-7301  
america@boerger.com  
www.boerger.com

Ad on page 55

**Charter Machine Company**  
Metuchen, NJ  
732-548-4400  
walterk@chartermachine.com  
www.chartermachine.com

**Hawkins Water Treatment Group**  
Roseville, MN  
800-328-5460 • 612-331-6910 • Fax: 612-331-5304  
laura.eilek@hawkinsinc.com  
www.hawkinsinc.com

**Hydrite Chemical Co.**  
Brookfield, WI  
262-792-1450  
marketing@hydrite.com  
www.hydrite.com

**Rhino Linings Corporation**  
San Diego, CA  
800-747-6966 • 858-450-0441 • Fax: 858-450-6881  
sales@rhinolinings.com  
www.rhinolinings.com

Ad on page 19

**Trident Processes LLC**  
Sumas, WA  
800-799-3740 • 604-330-2500  
info@tridentprocesses.com  
www.tridentprocesses.com

**Pressure Washers  
and Sprayers**

**Cam Spray**  
Iowa Falls, IA  
800-648-5011 • 641-648-5011 • Fax: 641-648-5013  
sales@camspray.com  
www.camspray.com

Ad on page 87

**Process Control Equipment**

**AMETEK Drexelbrook**  
Horsham, PA  
215-674-1234 • Fax: 215-674-2731  
drexelbrook.info@ametek.com  
www.drexelbrook.com



**Anue Water Technologies, Inc.**  
Oceanside, CA  
760-727-2683  
info@anuewater.com  
www.anuewater.com

**ASA Analytics**  
Waukesha, WI  
262-717-9500 • Fax: 262-717-9530  
info@chemscan.com  
www.asaanalytics.com



**Blue-White Industries**  
Huntington Beach, CA  
714-893-8529 • Fax: 714-894-9492  
sales@blue-white.com  
www.blue-white.com

Ad on page 2



**Emerson Automation Solutions**  
Pittsburgh, PA  
800-445-9723 • 412-963-4000  
powerwater@emerson.com  
www.emerson.com/water

**Endress+Hauser**

**Endress+Hauser**  
Greenwood, IN  
888-363-7377 • Fax: 317-535-8498  
info@us.endress.com  
www.us.endress.com

**FCI - Fluid Components International**  
San Marcos, CA  
800-854-1993 • 760-744-6950 • Fax: 760-736-6250  
eflow@fluidcomponents.com  
www.fluidcomponents.com

**Ford Hall Company, Inc.**  
Richmond, KY  
859-624-1077 • Fax: 859-624-3320  
sperry@fordhall.com  
www.weir-wolf.com

Ad on page 79



**MARSH MCBIRNEY SIGMA**  
**Hach**  
Loveland, CO  
800-227-4224 • 970-669-3050  
orders@hach.com  
www.hach.com

Ad on page 5

**Hawk Measurement**  
Lawrence, MA  
888-429-5538 • 978-304-3000 • Fax: 978-304-1462  
info@hawkmeasure.com  
www.hawkmeasure.com

**Hydromantis Environmental Software Solutions, Inc.**  
Hamilton, ON Canada  
905-522-0012 • Fax: 905-522-0031  
info@hydromantis.com  
www.hydromantis.com



**Lutz-JESCO America Corp.**  
Rochester, NY  
800-554-2762 • 585-426-0990 • Fax: 585-426-4025  
mail@jescoamerica.com  
www.lutzjescoamerica.com

**McCrometer Inc.**  
Hemet, CA  
800-220-2279 • 951-652-6811 • Fax: 951-652-3078  
customerservice@mccrometer.com  
www.mccrometer.com

**MoistTech Corp.**  
Sarasota, FL  
941-351-7870  
www.moisttech.com/

**Ovivo USA, LLC**  
Austin, TX  
512-834-6000 • Fax: 512-834-6039  
info.us@ovivowater.com  
www.ovivowater.com

**Phoenix Contact**  
Middletown, PA  
800-888-7388 • 717-944-1300  
info@phoenixcon.com  
www.phoenixcontact.com/usa\_home

**PMC Engineering**  
Danbury, CT  
203-792-8686 • Fax: 203-743-2051  
sales@pmc1.com  
www.pmc1.com

**PolyScience**  
Niles, IL  
800-229-7569 • 847-647-0611 • Fax: 847-647-1155  
sales@polyscience.com  
www.polyscience.com

**Praxair, Inc.**  
Burr Ridge, IL  
800-772-9247 • 630-320-4000 • Fax: 630-320-4508  
info@praxair.com  
www.praxair.com/wastewater

**Pulsafeeder, Inc.**  
Punta Gorda, FL  
800-333-6677 • 941-575-3800 • Fax: 941-575-4085  
ppgspotech@idexcorp.com  
www.pulsatron.com

**Sensorex**  
Garden Grove, CA  
800-835-4344 • 714-895-4344  
sales@sensorex.com  
www.sensorex.com

**Sierra Instruments, Inc.**  
Monterey, CA  
800-866-0200 • 831-373-0200 • Fax: 831-373-4402  
info@sierrainstruments.com  
www.sierrainstruments.com

**Sure Flow Products, LLC**  
Wixom, MI  
248-380-3569 • Fax: 248-380-3568  
sales@sureflowproducts.com  
www.flowmetersource.com

**Trihedral Engineering Limited**  
Bedford, NS  
Canada  
800-463-2783 • 902-835-1575 • Fax: 902-835-0369  
pcooke@trihedral.com  
www.trihedral.com



**Varec Biogas**  
Huntington Beach, CA  
866-424-6427 • Fax: 714-952-2701  
info@varec-biogas.com  
www.varec-biogas.com

**Programmable Logic Controllers/Timers**

**AdEdge Water Technologies, LLC**  
Duluth, GA  
866-823-3343 • 678-835-0052 • Fax: 678-835-0057  
sales@adedge technologies.com  
www.adedgetech.com

Ad on page 25

**Phoenix Contact**  
Middletown, PA  
800-888-7388 • 717-944-1300  
info@phoenixcon.com  
www.phoenixcontact.com/usa\_home

**Pump Controls**

**AMETEK Drexelbrook**  
Horsham, PA  
215-674-1234 • Fax: 215-674-2731  
drexelbrook.info@ametek.com  
www.drexelbrook.com

**Busch Vacuum Pumps and Systems**  
Virginia Beach, VA  
800-872-7867 • 757-463-7800 • Fax: 757-463-7407  
marketing@buschusa.com  
www.buschusa.com

**Crane Pumps & Systems**  
Piqua, OH  
937-778-8947 • Fax: 937-773-7157  
cranepumps@cranepumps.com  
www.cranepumps.com

**Data Flow Systems, Inc.**  
Melbourne, FL  
321-259-5009 • Fax: 321-259-4006  
info@dataflowsys.com  
www.dataflowsys.com

**EBARA Fluid Handling**  
Rock Hill, SC  
803-327-5005 • Fax: 803-327-5097  
sales@pumpsebara.com  
www.pumpsebara.com

**Emerson Automation Solutions**  
Pittsburgh, PA  
800-445-9723 • 412-963-4000  
powerwater@emerson.com  
www.emerson.com/water

**Gardner Denver Inc.**  
Quincy, IL  
866-428-4890 • Fax: 217-221-8780  
www.gardnerdenver.com/gdproducts

Ad on page 61

**Gorman-Rupp Company**  
Mansfield, OH  
419-755-1011 • Fax: 419-755-1251  
grsales@gormanrupp.com  
www.GRpumps.com



**Your Turn Key Solution For Steel, Concrete and Fiberglass Tank Lining, Coating and Repairs**

**AmTech**  
★ ★ ★ Tank Lining Systems

**Serving 50 States and Canada**  
**(888) 839-0373**

www.amtechtanklining.com info@amtechtanklining.com

FREE INFO – SEE ADVERTISER INDEX

**ROTARY PRESS**

**SLUDGE DEWATERING**



Patented technology

- > High Cake Dryness
- > Fully-Automated
- > Expandable Technology
- > Operator Friendly
- > For Municipal and Industrial Application

**OVER 430 | INSTALLATIONS WORLDWIDE**

**Fournier**

418 423-4241 | www.rotary-press.com | www.fournierindustries.com

FREE INFO – SEE ADVERTISER INDEX

**Harwil Corp.**  
Oxnard, CA  
805-988-6800 • Fax: 805-988-6804  
sales@harwil.com  
www.harwil.com

**IWAKI America**  
Holliston, MA  
508-429-1440  
info@iwakiamerica.com  
www.iwakiamerica.com



**Komline-Sanderson**  
Peapack, NJ  
800-225-5457 • 908-234-1000 • Fax: 908-234-9487  
info@komline.com  
www.komline.com

Ad on page 69

**KSB, Inc.**  
Henrico, VA  
800-945-7867 • 804-222-1818 • Fax: 804-226-6961  
sales@ksbusa.com  
www.ksbusa.com

**Lutz-JESCO America Corp.**  
Rochester, NY  
800-554-2762 • 585-426-0990 • Fax: 585-426-4025  
mail@jescoamerica.com  
www.lutzjescoamerica.com

**NETZSCH Pumps North America, LLC**  
Exton, PA  
610-363-8010 • Fax: 610-363-0971  
npa@netzsch.com  
www.pumps.netzsch.com

**Peabody Engineering and Supply Inc.**  
Corona, CA  
877-734-3759 • Fax: 951-734-4111  
sales@4peabody.com  
www.4peabody.com

**Phoenix Contact**  
Middletown, PA  
800-888-7388 • 717-944-1300  
info@phoenixcon.com  
www.phoenixcontact.com/usa\_home



**PRIMEX**  
Detroit Lakes, MN  
888-342-5753 • 218-847-1317 • Fax: 218-847-4617  
info@primexcontrols.com  
www.primexcontrols.com

**ProMinent Fluid Controls, Inc.**  
Pittsburgh, PA  
412-787-2484 • Fax: 412-787-0704  
sales@prominent.us  
www.prominent.us

**Pulsafeeder, Inc.**  
Punta Gorda, FL  
800-333-6677 • 941-575-3800 • Fax: 941-575-4085  
ppgspotech@idexcorp.com  
www.pulsatron.com

**Ronk Electrical**  
Nokomis, IL  
800-221-7665 • 217-563-8333 • Fax: 217-563-8336  
sales@ronkelectrical.com  
www.ronkelectrical.com

Ad on page 116

**SEEPEx Inc.**  
Enon, OH  
937-864-7150 • Fax: 937-864-7157  
sales.us@seepex.com  
www.seepex.com

Ad on page 71

**Sensaphone**  
Aston, PA  
877-373-2700 • 610-558-2700 • Fax: 610-558-0222  
contact@sensaphone.com  
www.sensaphone.com

**Smith & Loveless, Inc.**  
Lenexa, KS  
800-898-9122 • 913-888-5201  
answers@smithandloveless.com  
www.smithandloveless.com

**Sulzer Pumps Solutions Inc.**  
Meriden, CT  
800-525-7790 • 203-238-2700 • Fax: 203-238-0738  
info.abs.usa@sulzer.com  
www.sulzer.com

**Wastecorp Pumps**  
Grand Island, New York  
888-829-2783 • 201-445-2882 • Fax: 888-888-3320  
info@wastecorp.com  
www.wastecorp.com

**Zoeller Pump Company**  
Louisville, KY  
800-928-7867 • 502-778-2731  
www.zoeller.com

## Pump Parts/Supplies/ Service

**Busch Vacuum Pumps and Systems**  
Virginia Beach, VA  
800-872-7867 • 757-463-7800 • Fax: 757-463-7407  
marketing@buschusa.com  
www.buschusa.com

**Crane Pumps & Systems**  
Piqua, OH  
937-778-8947 • Fax: 937-773-7157  
cranepumps@cranepumps.com  
www.cranepumps.com



**Dragon Products, Ltd.**  
Beaumont, TX  
800-231-8198  
sales@modernusa.com  
www.dragonproducts.com

**Flowrox, Inc.**  
Linthicum, MD  
410-636-2250 • Fax: 410-636-9062  
sales-us@flowrox.com  
www.flowrox.com

**Gardner Denver Inc.**  
Quincy, IL  
866-428-4890 • Fax: 217-221-8780  
www.gardnerdenver.com/gdproducts  
Ad on page 61

**Gorman-Rupp Company**  
Mansfield, OH  
419-755-1011 • Fax: 419-755-1251  
g-sales@gormanrupp.com  
www.GRPumps.com

**Hawkins Water Treatment Group**  
Roseville, MN  
800-328-5460 • 612-331-6910 • Fax: 612-331-5304  
laura.eilek@hawkinsinc.com  
www.hawkinsinc.com



**Komline-Sanderson**  
Peapack, NJ  
800-225-5457 • 908-234-1000 • Fax: 908-234-9487  
info@komline.com  
www.komline.com

Ad on page 69

**KSB, Inc.**  
Henrico, VA  
800-945-7867 • 804-222-1818 • Fax: 804-226-6961  
sales@ksbusa.com  
www.ksbusa.com

**Lutz-JESCO America Corp.**  
Rochester, NY  
800-554-2762 • 585-426-0990 • Fax: 585-426-4025  
mail@jescoamerica.com  
www.lutzjescoamerica.com

**NETZSCH Pumps North America, LLC**  
Exton, PA  
610-363-8010 • Fax: 610-363-0971  
npa@netzsch.com  
www.pumps.netzsch.com

**Philadelphia Gear - A Timken Brand**  
King of Prussia, PA  
800-766-5120 • 610-265-3000 • Fax: 610-337-5637  
info@philagear.com  
www.philagear.com

**Pulsafeeder, Inc.**  
Punta Gorda, FL  
800-333-6677 • 941-575-3800 • Fax: 941-575-4085  
ppgspotech@idexcorp.com  
www.pulsatron.com

**Rebuild-It Service Group, LLC**  
Midvale, UT  
888-709-5676 • Fax: 385-355-6989  
treymburn@rebuild-it.com  
www.rebuild-it.com

**Smith & Loveless, Inc.**  
Lenexa, KS  
800-898-9122 • 913-888-5201  
answers@smithandloveless.com  
www.smithandloveless.com

**SRS Crisafulli, Inc.**  
Glendive, MT  
800-442-7867 • 406-365-3393 • Fax: 406-365-8088  
srs@crisafulli.com  
www.crisafullipumps.com

**Sulzer Pumps Solutions Inc.**  
Meriden, CT  
800-525-7790 • 203-238-2700 • Fax: 203-238-0738  
info.abs.usa@sulzer.com  
www.sulzer.com

**Wastecorp Pumps**  
Grand Island, New York  
888-829-2783 • 201-445-2882 • Fax: 888-888-3320  
info@wastecorp.com  
www.wastecorp.com

**Wastewater Depot, LLC**  
Batavia, OH  
513-732-0129 • Fax: 513-735-1485  
info@wastewaterdepot.com  
www.wastewaterdepot.com

## WEMCO®

**Weir Specialty Pumps (WEMCO)**  
Salt Lake City, UT  
801-359-8731 • Fax: 801-530-7828  
wemco@mail.weir  
www.global.weir

## Pumps - Alignment/ Vibration



**Proco Products, Inc.**  
Stockton, CA  
800-344-3246 • 209-943-6088 • Fax: 209-943-0242  
sales@procoproducts.com  
www.procoproducts.com

**Wastecorp Pumps**  
Grand Island, New York  
888-829-2783 • 201-445-2882 • Fax: 888-888-3320  
info@wastecorp.com  
www.wastecorp.com

## Pumps - Archimedes/ Screw

**Hidrostral Pumps**  
Aurora, IL  
630-948-3355 • Fax: 630-948-3353  
info@hidrostralpumps.com  
www.hidrostralpumps.com

**JDV Equipment Corporation**  
Dover, NJ  
973-366-6556 • Fax: 973-366-3193  
sales@jdvequipment.com  
www.jdvequipment.com

Ad on page 83



Cleaner Water for a Brighter Future®  
**Lakeside Equipment Corporation**  
Bartlett, IL  
630-837-5640 • Fax: 630-837-5647  
sales@lakeside-equipment.com  
www.lakeside-equipment.com

Ad on page 3



**Ruthman Companies**  
Cincinnati, OH  
859-824-3100 • Fax: 859-824-7248  
www.gusher.com/contact-us  
www.ruthmancompanies.com/ruthman-companies

Ad on page 37



**Pumps - Centrifugal**

**Crane Pumps & Systems**

Piqua, OH  
937-778-8947 • Fax: 937-773-7157  
cranepumps@cranepumps.com  
www.cranepumps.com



**Dragon Products, Ltd.**

Beaumont, TX  
800-231-8198  
sales@modernusa.com  
www.dragonproductsLtd.com

**EBARA Fluid Handling**

Rock Hill, SC  
803-327-5005 • Fax: 803-327-5097  
sales@pumpsebara.com  
www.pumpsebara.com

**Gardner Denver Inc.**

Quincy, IL  
866-428-4890 • Fax: 217-221-8780  
www.gardnerdenver.com/gdproducts  
Ad on page 61



**Gorman-Rupp Company**

Mansfield, OH  
419-755-1011 • Fax: 419-755-1251  
grsales@gormanrupp.com  
www.GRpumps.com

**Hawkins Water Treatment Group**

Roseville, MN  
800-328-5460 • 612-331-6910 • Fax: 612-331-5304  
laura.eilek@hawkinsinc.com  
www.hawkinsinc.com

**Hidrostal Pumps**

Aurora, IL  
630-948-3355 • Fax: 630-948-3353  
info@hidrostalpumps.com  
www.hidrostalpumps.com

**Hydra-Tech Pumps**

Nesquehoning, PA  
570-645-3779 • Fax: 570-645-4061  
htpump@hydra-tech.com  
www.hydra-tech.com

**IWAKI America**

Holliston, MA  
508-429-1440  
info@iwakiamerica.com  
www.iwakiamerica.com

**JDV Equipment Corporation**

Dover, NJ  
973-366-6556 • Fax: 973-366-3193  
sales@jdvequipment.com  
www.jdvequipment.com

**Ad on page 83**

**Kifco, Inc.**

Havana, IL  
800-452-7017 • 309-543-4425 • Fax: 309-543-4945  
sales@kifco.com  
www.kifco.com

**Ad on page 116**

**KSB, Inc.**

Henrico, VA  
800-945-7867 • 804-222-1818 • Fax: 804-226-6961  
sales@ksbusa.com  
www.ksbusa.com

**Lutz-JESCO America Corp.**

Rochester, NY  
800-554-2762 • 585-426-0990 • Fax: 585-426-4025  
mail@jescoamerica.com  
www.lutzjescoamerica.com

**Rain for Rent**

Bakersfield, CA  
800-742-7246 • 661-399-9124  
info@rainforrent.com  
www.rainforrent.com

**Red Valve Co. / Tideflex Technologies**

Carnegie, PA  
412-279-0044 • Fax: 412-279-7878  
sales@redvalve.com  
www.redvalve.com

**Ad on page 35**

**Robuschi USA**

Quincy, IL  
866-428-4890 • Fax: 217-221-8780  
www.gardnerdenver.com/robuschi/  
Ad on page 119



**Ruthman Companies**

Cincinnati, OH  
859-824-3100 • Fax: 859-824-7248  
www.gusher.com/contact-us  
www.ruthmancompanies.com/ruthman-companies

**Ad on page 37**

**Smith & Loveless, Inc.**

Lenexa, KS  
800-898-9122 • 913-888-5201  
answers@smithandloveless.com  
www.smithandloveless.com

**Sulzer Pumps Solutions Inc.**

Meriden, CT  
800-525-7790 • 203-238-2700 • Fax: 203-238-0738  
info.abs.usa@sulzer.com  
www.sulzer.com

**Sunbelt Rentals**

Fort Mill, SC  
800-736-2504  
www.sunbeltrentals.com

**Ad on page 27**

**Tapflo**

S-442 34 Kungv/Sjv  
Sweden  
004630363390  
sales@tapflo.com  
www.tapflo.com

**Vaughan Company, Inc.**

Montesano, WA  
888-249-2467 • 360-249-4042 • Fax: 360-249-6155  
info@chopperpumps.com  
www.chopperpumps.com

**Ad on page 120**

**DEEP TREKKER™**



Internally Battery Powered  
**DEEP TREKKER 340 PIPE CRAWLER**  
Starting At \$9,999<sup>USD</sup>

WWW.DEEPTREKKER.COM

FREE INFO – SEE ADVERTISER INDEX

**Composting Performance**

**Staggered Rotor Industrial Series Mixers**  
Superior blend with reduced maintenance and operating cost.



Patented Staggered Rotor

**Waste Pro Series Mixers** quickly and efficiently process food waste, cardboard and yard waste.

**Vertical Compost Series**

process and incorporate coarse carbon sources quickly and efficiently.



Watch videos  
www.rotomix.com



Take time today,  
call for more information!  
**620.338.0090** Cell  
**620.225.1142**

Depend on the Leader

FREE INFO – SEE ADVERTISER INDEX

**Wastecorp Pumps**  
Grand Island, New York  
888-829-2783 • 201-445-2882 • Fax: 888-888-3320  
info@wastecorp.com  
www.wastecorp.com

**Weir Specialty Pumps (WEMCO)**  
Salt Lake City, UT  
801-359-8731 • Fax: 801-530-7828  
wemco@mail.weir  
www.global.weir

**Zoeller Pump Company**  
Louisville, KY  
800-928-7867 • 502-778-2731  
www.zoeller.com

## Pumps - Chemical Feed



**Blue-White Industries**  
Huntington Beach, CA  
714-893-8529 • Fax: 714-894-9492  
sales@blue-white.com  
www.blue-white.com  
**Ad on page 2**

**Boerger, LLC**  
Chanhassen, MN  
612-435-7300 • Fax: 612-435-7301  
america@boerger.com  
www.boerger.com  
**Ad on page 55**

**Flowrox, Inc.**  
Linthicum, MD  
410-636-2250 • Fax: 410-636-9062  
sales-us@flowrox.com  
www.flowrox.com

**Harwil Corp.**  
Oxnard, CA  
805-988-6800 • Fax: 805-988-6804  
sales@harwil.com  
www.harwil.com

**Hawkins Water Treatment Group**  
Roseville, MN  
800-328-5460 • 612-331-6910 • Fax: 612-331-5304  
laura.eilek@hawkinsinc.com  
www.hawkinsinc.com

**Hayward Flow Control**  
Clemmons, NC  
888-429-4635 • Fax: 888-778-8410  
hfcsales@hayward.com  
www.haywardflowcontrol.com  
**Ad on page 15**

**IWAKI America**  
Holliston, MA  
508-429-1440  
info@iwakiamerica.com  
www.iwakiamerica.com

**Lutz-JESCO America Corp.**  
Rochester, NY  
800-554-2762 • 585-426-0990 • Fax: 585-426-4025  
mail@jescoamerica.com  
www.lutzjescoamerica.com

**NETZSCH Pumps North America, LLC**  
Exton, PA  
610-363-8010 • Fax: 610-363-0971  
npa@netsch.com  
www.pumps.netsch.com

**Peabody Engineering and Supply Inc.**  
Corona, CA  
877-734-3759 • Fax: 951-734-4111  
sales@4peabody.com  
www.4peabody.com



**Penn Valley Pump Co., Inc.**  
Warrington, PA  
800-311-3311 • 215-343-8750 • Fax: 215-343-8753  
info@pennvalleypump.com  
www.pennvalleypump.com  
**Ad on page 41**

**ProMinent Fluid Controls, Inc.**  
Pittsburgh, PA  
412-787-2484 • Fax: 412-787-0704  
sales@prominent.us  
www.prominent.us

**Pulsafeeder, Inc.**  
Punta Gorda, FL  
800-333-6677 • 941-575-3800 • Fax: 941-575-4085  
ppgspotech@idexcorp.com  
www.pulsatron.com

**SEEPEx Inc.**  
Enon, OH  
937-864-7150 • Fax: 937-864-7157  
sales.us@seepex.com  
www.seepex.com  
**Ad on page 71**

**Wastecorp Pumps**  
Grand Island, New York  
888-829-2783 • 201-445-2882 • Fax: 888-888-3320  
info@wastecorp.com  
www.wastecorp.com

**Watson-Marlow Fluid Technology Group**  
Wilmington, MA  
800-282-8823 • 978-658-6168 • Fax: 978-658-0041  
support@wmpg.us  
www.watson-marlow.com  
**Ad on page 53**

## Pumps - Chopper

**JDV Equipment Corporation**  
Dover, NJ  
973-366-6556 • Fax: 973-366-3193  
sales@jdvequipment.com  
www.jdvequipment.com  
**Ad on page 83**

**Kifco, Inc.**  
Havana, IL  
800-452-7017 • 309-543-4425 • Fax: 309-543-4945  
sales@kifco.com  
www.kifco.com  
**Ad on page 116**



**Ruthman Companies**  
Cincinnati, OH  
859-824-3100 • Fax: 859-824-7248  
www.gusher.com/contact-us  
www.ruthmancompanies.com/ruthman-companies  
**Ad on page 37**

**SEEPEx Inc.**  
Enon, OH  
937-864-7150 • Fax: 937-864-7157  
sales.us@seepex.com  
www.seepex.com  
**Ad on page 71**

**Sulzer Pumps Solutions Inc.**  
Meriden, CT  
800-525-7790 • 203-238-2700 • Fax: 203-238-0738  
info.abs.usa@sulzer.com  
www.sulzer.com

**Vaughan Company, Inc.**  
Montesano, WA  
888-249-2467 • 360-249-4042 • Fax: 360-249-6155  
info@chopperpumps.com  
www.chopperpumps.com  
**Ad on page 120**

**Wastecorp Pumps**  
Grand Island, New York  
888-829-2783 • 201-445-2882 • Fax: 888-888-3320  
info@wastecorp.com  
www.wastecorp.com

## WEMCO®

**Weir Specialty Pumps (WEMCO)**  
Salt Lake City, UT  
801-359-8731 • Fax: 801-530-7828  
wemco@mail.weir  
www.global.weir

## Pumps - Deep Well

**Kifco, Inc.**  
Havana, IL  
800-452-7017 • 309-543-4425 • Fax: 309-543-4945  
sales@kifco.com  
www.kifco.com  
**Ad on page 116**

**KSB, Inc.**  
Henrico, VA  
800-945-7867 • 804-222-1818 • Fax: 804-226-6961  
sales@ksbusa.com  
www.ksbusa.com



**Ruthman Companies**  
Cincinnati, OH  
859-824-3100 • Fax: 859-824-7248  
www.gusher.com/contact-us  
www.ruthmancompanies.com/ruthman-companies  
**Ad on page 37**

**Sulzer Pumps Solutions Inc.**  
Meriden, CT  
800-525-7790 • 203-238-2700 • Fax: 203-238-0738  
info.abs.usa@sulzer.com  
www.sulzer.com

## Pumps - Dewatering/ Bypass

**Crane Pumps & Systems**  
Piqua, OH  
937-778-8947 • Fax: 937-773-7157  
cranepumps@cranepumps.com  
www.cranepumps.com

**EBARA Fluid Handling**  
Rock Hill, SC  
803-327-5005 • Fax: 803-327-5097  
sales@pumpsebara.com  
www.pumpsebara.com

**Gardner Denver Inc.**  
Quincy, IL  
866-428-4890 • Fax: 217-221-8780  
www.gardnerdenver.com/gdproducts  
**Ad on page 61**

**GOR PUMPS**  
**Gorman-Rupp Company**  
Mansfield, OH  
419-755-1011 • Fax: 419-755-1251  
grsales@gormanrupp.com  
www.GRpumps.com

**Hydra-Tech Pumps**  
Nesquehoning, PA  
570-645-3779 • Fax: 570-645-4061  
htpump@hydra-tech.com  
www.hydra-tech.com

**Komline-Sanderson**  
**Komline-Sanderson**  
Peapack, NJ  
800-225-5457 • 908-234-1000 • Fax: 908-234-9487  
info@komline.com  
www.komline.com  
**Ad on page 69**

**NETZSCH Pumps North America, LLC**  
Exton, PA  
610-363-8010 • Fax: 610-363-0971  
npa@netsch.com  
www.pumps.netsch.com



**Rain for Rent**  
Bakersfield, CA  
800-742-7246 • 661-399-9124  
info@rainforrent.com  
www.rainforrent.com

**ScreenCo Systems LLC**  
Geneseo, ID  
208-790-8770  
sales@screenco.com  
www.screenco.com  
**Ad on page 116**

**SRS Crisafulli, Inc.**  
Glendive, MT  
800-442-7867 • 406-365-3393 • Fax: 406-365-8088  
srs@crisafulli.com  
www.crisafullipumps.com



**Sulzer Pumps Solutions Inc.**  
Meriden, CT  
800-525-7790 • 203-238-2700 • Fax: 203-238-0738  
info.abs.usa@sulzer.com  
www.sulzer.com

**Sunbelt Rentals**

Fort Mill, SC  
800-736-2504  
www.sunbeltrentals.com

Ad on page 27

**Vaughan Company, Inc.**

Montesano, WA  
888-249-2467 • 360-249-4042 • Fax: 360-249-6155  
info@chopperpumps.com  
www.chopperpumps.com

Ad on page 120

**Wastecorp Pumps**

Grand Island, New York  
888-829-2783 • 201-445-2882 • Fax: 888-888-3320  
info@wastecorp.com  
www.wastecorp.com

**Weir Specialty Pumps (WEMCO)**

Salt Lake City, UT  
801-359-8731 • Fax: 801-530-7828  
wemco@mail.weir  
www.global.weir

**Zoeller Pump Company**

Louisville, KY  
800-928-7867 • 502-778-2731  
www.zoeller.com

**Pumps - Diaphragm**



**Blue-White Industries**

Huntington Beach, CA  
714-893-8529 • Fax: 714-894-9492  
sales@blue-white.com  
www.blue-white.com

Ad on page 2

**Hawkins Water Treatment Group**

Roseville, MN  
800-328-5460 • 612-331-6910 • Fax: 612-331-5304  
laura.eilek@hawkinsinc.com  
www.hawkinsinc.com

**IWAKI America**

Holliston, MA  
508-429-1440  
info@iwakiamerica.com  
www.iwakiamerica.com

**Lutz-JESCO America Corp.**

Rochester, NY  
800-554-2762 • 585-426-0990 • Fax: 585-426-4025  
mail@jescoamerica.com  
www.lutzjescoamerica.com



**Penn Valley Pump Co., Inc.**

Warrington, PA  
800-311-3311 • 215-343-8750 • Fax: 215-343-8753  
info@pennvalleypump.com  
www.pennvalleypump.com

Ad on page 41

**ProMinent Fluid Controls, Inc.**

Pittsburgh, PA  
412-787-2484 • Fax: 412-787-0704  
sales@prominent.us  
www.prominent.us

**Pulsafeeder, Inc.**

Punta Gorda, FL  
800-333-6677 • 941-575-3800 • Fax: 941-575-4085  
ppgspotech@idexcorp.com  
www.pulsatron.com

**Rain for Rent**

Bakersfield, CA  
800-742-7246 • 661-399-9124  
info@rainforrent.com  
www.rainforrent.com

**Ruthman Companies**

Cincinnati, OH  
859-824-3100 • Fax: 859-824-7248  
www.gusher.com/contact-us  
www.ruthmancompanies.com/ruthman-companies

Ad on page 37

**Sunbelt Rentals**

Fort Mill, SC  
800-736-2504  
www.sunbeltrentals.com

Ad on page 27

**Tapflo**

S-442 34 Kungv/Slv  
Sweden  
004630363390  
sales@tapflo.com  
www.tapflo.com

**Wastecorp Pumps**

Grand Island, New York  
888-829-2783 • 201-445-2882 • Fax: 888-888-3320  
info@wastecorp.com  
www.wastecorp.com

**Pumps - Effluent**

**Crane Pumps & Systems**

Piqua, OH  
937-778-8947 • Fax: 937-773-7157  
cranepumps@cranepumps.com  
www.cranepumps.com

**EBARA Fluid Handling**

Rock Hill, SC  
803-327-5005 • Fax: 803-327-5097  
sales@pumpsebara.com  
www.pumpsebara.com

**Flowrox, Inc.**

Linthicum, MD  
410-636-2250 • Fax: 410-636-9062  
sales-us@flowrox.com  
www.flowrox.com

**Gorman-Rupp Company**

Mansfield, OH  
419-755-1011 • Fax: 419-755-1251  
grsales@gormanrupp.com  
www.GRpumps.com

**KSB, Inc.**

Henrico, VA  
800-945-7867 • 804-222-1818 • Fax: 804-226-6961  
sales@ksbusa.com  
www.ksbusa.com

**Dependable, High Quality Blowers**  
**Price Savings Unmatched By Others**

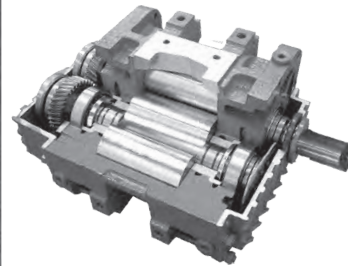

**MB and ZG Series Blowers**

Duroflow and RAM/RCS Replacements  
Bi-lobe and tri-lobe models

Pressures to 15 PSIG  
Airflow to 5,000 CFM

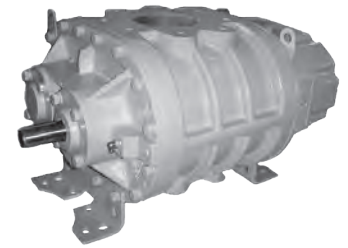

**ZZ Series Blowers**

Drop-in Replacement for Roots  
URAI, Sutorbilt Legend and Tuthill  
Competitor Models

Pressures to 15 PSIG  
Airflow to 2,350 CFM



**EurusBlower**

PO Box 4588, Wheaton, IL 60189

PH: 630-221-8282 FX: 630-221-1002

www.eurusblower.com tomh@eurusbLOWER.com

FREE INFO - SEE ADVERTISER INDEX

GET  
**EMAIL NEWS**  
**ALERTS** FOR  
TREATMENT PLANT OPERATOR  
**tpo**  
Go to  
[tpomag.com/alerts](http://tpomag.com/alerts)  
and get started today!

**UV Disinfection**  
**SALCOR | PROVEN SOLUTIONS SINCE 1978**

- Fouling-Resistant Teflon® Barrier
- To 100,000+ GPD
- “Building Block” 9,000 GPD Module In Arrays Reliable/Easily Expandable
- Inactivates Deadly Pathogens
- Low Cost/Gravity Flow < 30 Watts
- Quick Install/O&M
- Continuously Monitored

3G UNIT **760.731.0745** [jscraver@aol.com](mailto:jscraver@aol.com)

FREE INFO - SEE ADVERTISER INDEX

**Rain for Rent**  
Bakersfield, CA  
800-742-7246 • 661-399-9124  
info@rainforrent.com  
www.rainforrent.com

**Smith & Loveless, Inc.**  
Lenexa, KS  
800-898-9122 • 913-888-5201  
answers@smithandloveless.com  
www.smithandloveless.com

**Sulzer Pumps Solutions Inc.**  
Meriden, CT  
800-525-7790 • 203-238-2700 • Fax: 203-238-0738  
info.abs.usa@sulzer.com  
www.sulzer.com

**Sunbelt Rentals**  
Fort Mill, SC  
800-736-2504  
www.sunbeltrentals.com  
**Ad on page 27**

**Vaughan Company, Inc.**  
Montesano, WA  
888-249-2467 • 360-249-4042 • Fax: 360-249-6155  
info@chopperpumps.com  
www.chopperpumps.com  
**Ad on page 120**

**Wastecorp Pumps**  
Grand Island, New York  
888-829-2783 • 201-445-2882 • Fax: 888-888-3320  
info@wastecorp.com  
www.wastecorp.com

**Weir Specialty Pumps (WEMCO)**  
Salt Lake City, UT  
801-359-8731 • Fax: 801-530-7828  
wemco@mail.weir  
www.global.weir

**Zoeller Pump Company**  
Louisville, KY  
800-928-7867 • 502-778-2731  
www.zoeller.com

## Pumps - Grinder/Sump

**Crane Pumps & Systems**  
Piqua, OH  
937-778-8947 • Fax: 937-773-7157  
cranepumps@cranepumps.com  
www.cranepumps.com

**EBARA Fluid Handling**  
Rock Hill, SC  
803-327-5005 • Fax: 803-327-5097  
sales@pumpsebara.com  
www.pumpsebara.com

**Hidrostal Pumps**  
Aurora, IL  
630-948-3355 • Fax: 630-948-3353  
info@hidrostalpumps.com  
www.hidrostalpumps.com

**Hydra-Tech Pumps**  
Nesquehoning, PA  
570-645-3779 • Fax: 570-645-4061  
htpump@hydra-tech.com  
www.hydra-tech.com

**Milwaukee Rubber Products, Inc.**  
Menomonee Falls, WI  
800-325-3730 • 262-781-7888 • Fax: 262-781-1742  
sales@milwaukeeerubber.com  
www.milwaukeeerubber.com

**NETZSCH Pumps North America, LLC**  
Exton, PA  
610-363-8010 • Fax: 610-363-0971  
npa@netzsch.com  
www.pumps.netzsch.com

**Sulzer Pumps Solutions Inc.**  
Meriden, CT  
800-525-7790 • 203-238-2700 • Fax: 203-238-0738  
info.abs.usa@sulzer.com  
www.sulzer.com

**Vaughan Company, Inc.**  
Montesano, WA  
888-249-2467 • 360-249-4042 • Fax: 360-249-6155  
info@chopperpumps.com  
www.chopperpumps.com  
**Ad on page 120**

**Wastecorp Pumps**  
Grand Island, New York  
888-829-2783 • 201-445-2882 • Fax: 888-888-3320  
info@wastecorp.com  
www.pumps.netzsch.com

**Zoeller Pump Company**  
Louisville, KY  
800-928-7867 • 502-778-2731  
www.zoeller.com

## Pumps - High Pressure

 **Komline-Sanderson**  
Peapack, NJ  
800-225-5457 • 908-234-1000 • Fax: 908-234-9487  
info@komline.com  
www.komline.com  
**Ad on page 69**

**KSB, Inc.**  
Henrico, VA  
800-945-7867 • 804-222-1818 • Fax: 804-226-6961  
sales@ksbusa.com  
www.ksbusa.com

**Lutz-JESCO America Corp.**  
Rochester, NY  
800-554-2762 • 585-426-0990 • Fax: 585-426-4025  
mail@jescoamerica.com  
www.lutzjescoamerica.com

## Pumps - Metering

 **Blue-White Industries**  
Huntington Beach, CA  
714-893-8529 • Fax: 714-894-9492  
sales@blue-white.com  
www.blue-white.com  
**Ad on page 2**

**Flowrox, Inc.**  
Linthicum, MD  
410-636-2250 • Fax: 410-636-9062  
sales-us@flowrox.com  
www.flowrox.com

**Hawkins Water Treatment Group**  
Roseville, MN  
800-328-5460 • 612-331-6910 • Fax: 612-331-5304  
laura.eilek@hawkinsinc.com  
www.hawkinsinc.com

**Hayward Flow Control**  
Clemmons, NC  
888-429-4635 • Fax: 888-778-8410  
hfcsales@hayward.com  
www.haywardflowcontrol.com  
**Ad on page 15**

**IWAKI America**  
Holliston, MA  
508-429-1440  
info@iwakiamerica.com  
www.iwakiamerica.com

**Lutz-JESCO America Corp.**  
Rochester, NY  
800-554-2762 • 585-426-0990 • Fax: 585-426-4025  
mail@jescoamerica.com  
www.lutzjescoamerica.com

**NETZSCH Pumps North America, LLC**  
Exton, PA  
610-363-8010 • Fax: 610-363-0971  
npa@netzsch.com  
www.pumps.netzsch.com

**Peabody Engineering and Supply Inc.**  
Corona, CA  
877-734-3759 • Fax: 951-734-4111  
sales@4peabody.com  
www.4peabody.com

**ProMinent Fluid Controls, Inc.**  
Pittsburgh, PA  
412-787-2484 • Fax: 412-787-0704  
sales@prominent.us  
www.prominent.us

**Pulsafeeder, Inc.**  
Punta Gorda, FL  
800-333-6677 • 941-575-3800 • Fax: 941-575-4085  
ppgspotech@idexcorp.com  
www.pulsatron.com

**SEEPEx Inc.**  
Enon, OH  
937-864-7150 • Fax: 937-864-7157  
sales.us@seepex.com  
www.seepex.com  
**Ad on page 71**

**Watson-Marlow Fluid Technology Group**  
Wilmington, MA  
800-282-8823 • 978-658-6168 • Fax: 978-658-0041  
support@wmpg.us  
www.watson-marlow.com  
**Ad on page 53**

## Pumps - Peristaltic

 **Blue-White Industries**  
Huntington Beach, CA  
714-893-8529 • Fax: 714-894-9492  
sales@blue-white.com  
www.blue-white.com  
**Ad on page 2**

**Flowrox, Inc.**  
Linthicum, MD  
410-636-2250 • Fax: 410-636-9062  
sales-us@flowrox.com  
www.flowrox.com

**Gardner Denver Inc.**  
Quincy, IL  
866-428-4890 • Fax: 217-221-8780  
www.gardnerdenver.com/gdproducts  
**Ad on page 61**

**Hawkins Water Treatment Group**  
Roseville, MN  
800-328-5460 • 612-331-6910 • Fax: 612-331-5304  
laura.eilek@hawkinsinc.com  
www.hawkinsinc.com

**Lutz-JESCO America Corp.**  
Rochester, NY  
800-554-2762 • 585-426-0990 • Fax: 585-426-4025  
mail@jescoamerica.com  
www.lutzjescoamerica.com

**ProMinent Fluid Controls, Inc.**  
Pittsburgh, PA  
412-787-2484 • Fax: 412-787-0704  
sales@prominent.us  
www.prominent.us

**Pulsafeeder, Inc.**  
Punta Gorda, FL  
800-333-6677 • 941-575-3800 • Fax: 941-575-4085  
ppgspotech@idexcorp.com  
www.pulsatron.com

**Watson-Marlow Fluid Technology Group**  
Wilmington, MA  
800-282-8823 • 978-658-6168 • Fax: 978-658-0041  
support@wmpg.us  
www.watson-marlow.com  
**Ad on page 53**

## Pumps - Piston

 **Komline-Sanderson**  
Peapack, NJ  
800-225-5457 • 908-234-1000 • Fax: 908-234-9487  
info@komline.com  
www.komline.com  
**Ad on page 69**

## Pumps - Progressive Cavity

**DRYCAKE**  
Vancouver, BC  
Canada  
877-379-2253 • 604-535-2238  
sales@drycake.com  
www.drycake.com

**Flowrox, Inc.**  
Linthicum, MD  
410-636-2250 • Fax: 410-636-9062  
sales-us@flowrox.com  
www.flowrox.com

**Lutz-JESCO America Corp.**  
Rochester, NY  
800-554-2762 • 585-426-0990 • Fax: 585-426-4025  
mail@jescoamerica.com  
www.lutzjescoamerica.com

**NETZSCH Pumps North America, LLC**  
Exton, PA  
610-363-8010 • Fax: 610-363-0971  
npa@netzsch.com  
www.pumps.netzsch.com

**ScreenCo Systems LLC**  
Genesee, ID  
208-790-8770  
sales@screencosystems.com  
www.screencosystems.com  
**Ad on page 116**



## SEEPLEX Inc.

Enon, OH  
937-864-7150 • Fax: 937-864-7157  
sales.us@seepex.com  
www.seepex.com

Ad on page 71

## Wastecorp Pumps

Grand Island, New York  
888-829-2783 • 201-445-2882 • Fax: 888-888-3320  
info@wastecorp.com  
www.wastecorp.com

## Zoeller Pump Company

Louisville, KY  
800-928-7867 • 502-778-2731  
www.zoeller.com

## Pumps - Reciprocating



### Penn Valley Pump Co., Inc.

Warrington, PA  
800-311-3311 • 215-343-8750 • Fax: 215-343-8753  
info@pennvalleypump.com  
www.pennvalleypump.com

Ad on page 41

## Pumps - Rotary Lobe

### Boerger, LLC

Chanhassen, MN  
612-435-7300 • Fax: 612-435-7301  
america@boerger.com  
www.boerger.com

Ad on page 55

### NETZSCH Pumps North America, LLC

Exton, PA  
610-363-8010 • Fax: 610-363-0971  
npa@netsch.com  
www.pumps.netsch.com

## Wastecorp Pumps

Grand Island, New York  
888-829-2783 • 201-445-2882 • Fax: 888-888-3320  
info@wastecorp.com  
www.wastecorp.com

## Pumps - Solids/Sludge

### Boerger, LLC

Chanhassen, MN  
612-435-7300 • Fax: 612-435-7301  
america@boerger.com  
www.boerger.com

Ad on page 55

### Crane Pumps & Systems

Piqua, OH  
937-778-8947 • Fax: 937-773-7157  
cranepumps@cranepumps.com  
www.cranepumps.com



### Dragon Products, Ltd.

Beaumont, TX  
800-231-8198  
sales@modernusa.com  
www.dragonproductsltd.com

## EBARA Fluid Handling

Rock Hill, SC  
803-327-5005 • Fax: 803-327-5097  
sales@pumpsebara.com  
www.pumpsebara.com

## Gorman-Rupp Company

Mansfield, OH  
419-755-1011 • Fax: 419-755-1251  
grsales@gormanrupp.com  
www.GRpumps.com

## Hidrostal Pumps

Aurora, IL  
630-948-3355 • Fax: 630-948-3353  
info@hidrostalpumps.com  
www.hidrostalpumps.com

## Hydra-Tech Pumps

Nesquehoning, PA  
570-645-3779 • Fax: 570-645-4061  
htpump@hydra-tech.com  
www.hydra-tech.com

## IWAKI America

Holliston, MA  
508-429-1440  
info@iwakiamerica.com  
www.iwakiamerica.com

## JDV Equipment Corporation

Dover, NJ  
973-366-6556 • Fax: 973-366-3193  
sales@jdvequipment.com  
www.jdvequipment.com

Ad on page 83



## Komline-Sanderson

Peapack, NJ  
800-225-5457 • 908-234-1000 • Fax: 908-234-9487  
info@komline.com  
www.komline.com

Ad on page 69

## KSB, Inc.

Henrico, VA  
800-945-7867 • 804-222-1818 • Fax: 804-226-6961  
sales@ksbusa.com  
www.ksbusa.com

## Mud Cat, Division of Ellicott Dredge Technologies

New Richmond, WI  
866-467-4010 • 913-642-5100 • Fax: 913-642-5119  
sales@mudcatdredge.com  
www.mudcatdredge.com

## NETZSCH Pumps North America, LLC

Exton, PA  
610-363-8010 • Fax: 610-363-0971  
npa@netsch.com  
www.pumps.netsch.com



### Penn Valley Pump Co., Inc.

Warrington, PA  
800-311-3311 • 215-343-8750 • Fax: 215-343-8753  
info@pennvalleypump.com  
www.pennvalleypump.com

Ad on page 41

## Rain for Rent

Bakersfield, CA  
800-742-7246 • 661-399-9124  
info@rainforrent.com  
www.rainforrent.com

## Red Valve Co. / Tideflex Technologies

Carnegie, PA  
412-279-0044 • Fax: 412-279-7878  
sales@redvalve.com  
www.redvalve.com

Ad on page 35

## Robuschi USA

Quincy, IL  
866-428-4890 • Fax: 217-221-8780  
www.gardnerdenver.com/robuschi/

Ad on page 119



## Ruthman Companies

Cincinnati, OH  
859-824-3100 • Fax: 859-824-7248  
www.gusher.com/contact-us  
www.ruthmancompanies.com/ruthman-companies

Ad on page 37

## Schwing Bioset, Inc.

Somerset, WI  
844-246-7381 • 715-247-3433 • Fax: 715-247-3438  
marketing@schwingbioset.com  
www.schwingbioset.com

## ScreenCo Systems LLC

Genesee, ID  
208-790-8770  
sales@screencosystems.com  
www.screencosystems.com

Ad on page 116

## SEEPLEX Inc.

Enon, OH  
937-864-7150 • Fax: 937-864-7157  
sales.us@seepex.com  
www.seepex.com

Ad on page 71

## Smith & Loveless, Inc.

Lenexa, KS  
800-898-9122 • 913-888-5201  
answers@smithandloveless.com  
www.smithandloveless.com

## SRS Crisafulli, Inc.

Glendive, MT  
800-442-7867 • 406-365-3393 • Fax: 406-365-8088  
srsc@crisafulli.com  
www.crisafullipumps.com

## Sunbelt Rentals

Fort Mill, SC  
800-736-2504  
www.sunbeltrentals.com

Ad on page 27

## Vaughan Company, Inc.

Montesano, WA  
888-249-2467 • 360-249-4042 • Fax: 360-249-6155  
info@chopperpumps.com  
www.chopperpumps.com

Ad on page 120

## Wastecorp Pumps

Grand Island, New York  
888-829-2783 • 201-445-2882 • Fax: 888-888-3320  
info@wastecorp.com  
www.wastecorp.com

## Watson-Marlow Fluid Technology Group

Wilmington, MA  
800-282-8823 • 978-658-6168 • Fax: 978-658-0041  
support@wmpg.us  
www.watson-marlow.com

Ad on page 53

## WEMCO®

### Weir Specialty Pumps (WEMCO)

Salt Lake City, UT  
801-359-8731 • Fax: 801-530-7828  
wemco@mail.weir  
www.global.weir

## Pumps - Submersible

### Boerger, LLC

Chanhassen, MN  
612-435-7300 • Fax: 612-435-7301  
america@boerger.com  
www.boerger.com

Ad on page 55

### Crane Pumps & Systems

Piqua, OH  
937-778-8947 • Fax: 937-773-7157  
cranepumps@cranepumps.com  
www.cranepumps.com



### Dragon Products, Ltd.

Beaumont, TX  
800-231-8198  
sales@modernusa.com  
www.dragonproductsltd.com



## EBARA Fluid Handling

Rock Hill, SC  
803-327-5005 • Fax: 803-327-5097  
sales@pumpsebara.com  
www.pumpsebara.com

## Gorman-Rupp Company

Mansfield, OH  
419-755-1011 • Fax: 419-755-1251  
grsales@gormanrupp.com  
www.GRpumps.com

## Hidrostal Pumps

Aurora, IL  
630-948-3355 • Fax: 630-948-3353  
info@hidrostalpumps.com  
www.hidrostalpumps.com

## Hydra-Tech Pumps

Nesquehoning, PA  
570-645-3779 • Fax: 570-645-4061  
htpump@hydra-tech.com  
www.hydra-tech.com

## JDV Equipment Corporation

Dover, NJ  
973-366-6556 • Fax: 973-366-3193  
sales@jdvequipment.com  
www.jdvequipment.com

Ad on page 83

**KSB, Inc.**  
Henrico, VA  
800-945-7867 • 804-222-1818 • Fax: 804-226-6961  
sales@ksbusa.com  
www.ksbusa.com

**NETZSCH Pumps North America, LLC**  
Exton, PA  
610-363-8010 • Fax: 610-363-0971  
npa@netsch.com  
www.pumps.netsch.com

**Rain for Rent**  
Bakersfield, CA  
800-742-7246 • 661-399-9124  
info@rainforrent.com  
www.rainforrent.com



**Ruthman Companies**  
Cincinnati, OH  
859-824-3100 • Fax: 859-824-7248  
www.gusher.com/contact-us  
www.ruthmancompanies.com/ruthman-companies  
**Ad on page 37**

**SEEPLEX Inc.**  
Enon, OH  
937-864-7150 • Fax: 937-864-7157  
sales.us@seepex.com  
www.seepex.com  
**Ad on page 71**

**SRS Crisafulli, Inc.**  
Glendive, MT  
800-442-7867 • 406-365-3393 • Fax: 406-365-8088  
srsc@crisafulli.com  
www.crisafullipumps.com

**SULZER**  
Sulzer Pumps Solutions Inc.  
Meriden, CT  
800-525-7790 • 203-238-2700 • Fax: 203-238-0738  
info.abs.usa@sulzer.com  
www.sulzer.com

**Sunbelt Rentals**  
Fort Mill, SC  
800-736-2504  
www.sunbeltrentals.com  
**Ad on page 27**

**ValveUSA**  
786-571-8258  
info@valveusa.com  
www.valveusa.com

**Vaughan Company, Inc.**  
Montesano, WA  
888-249-2467 • 360-249-4042 • Fax: 360-249-6155  
info@chopperpumps.com  
www.chopperpumps.com  
**Ad on page 120**

**WEMCO®**  
Weir Specialty Pumps (WEMCO)  
Salt Lake City, UT  
801-359-8731 • Fax: 801-530-7828  
wemco@mail.weir  
www.global.weir

**Zoeller Pump Company**  
Louisville, KY  
800-928-7867 • 502-778-2731  
www.zoeller.com

## Pumps - Vacuum

**Busch Vacuum Pumps and Systems**  
Virginia Beach, VA  
800-872-7867 • 757-463-7800 • Fax: 757-463-7407  
marketing@buschusa.com  
www.buschusa.com

## Pumps - Vertical/ Lift Station

**Crane Pumps & Systems**  
Piqua, OH  
937-778-8947 • Fax: 937-773-7157  
cranepumps@cranepumps.com  
www.cranepumps.com

**Gorman-Rupp Company**  
Mansfield, OH  
419-755-1011 • Fax: 419-755-1251  
grsales@gormanrupp.com  
www.GRPumps.com

**Hidrostal Pumps**  
Aurora, IL  
630-948-3355 • Fax: 630-948-3353  
info@hidrostalpumps.com  
www.hidrostalpumps.com

**KSB, Inc.**  
Henrico, VA  
800-945-7867 • 804-222-1818 • Fax: 804-226-6961  
sales@ksbusa.com  
www.ksbusa.com

**Robuschi USA**  
Quincy, IL  
866-428-4890 • Fax: 217-221-8780  
www.gardnerdenver.com/robuschi/  
**Ad on page 119**

**Smith & Loveless, Inc.**  
Lenexa, KS  
800-898-9122 • 913-888-5201  
answers@smithandloveless.com  
www.smithandloveless.com

**SRS Crisafulli, Inc.**  
Glendive, MT  
800-442-7867 • 406-365-3393 • Fax: 406-365-8088  
srsc@crisafulli.com  
www.crisafullipumps.com

**Sulzer Pumps Solutions Inc.**  
Meriden, CT  
800-525-7790 • 203-238-2700 • Fax: 203-238-0738  
info.abs.usa@sulzer.com  
www.sulzer.com

**Tapflo**  
S-442 34 Kungv/Sjlv  
Sweden  
004630363390  
sales@tapflo.com  
www.tapflo.com

**Vaughan Company, Inc.**  
Montesano, WA  
888-249-2467 • 360-249-4042 • Fax: 360-249-6155  
info@chopperpumps.com  
www.chopperpumps.com  
**Ad on page 120**

**Wastecorp Pumps**  
Grand Island, New York  
888-829-2783 • 201-445-2882 • Fax: 888-888-3320  
info@wastecorp.com  
www.wastecorp.com

## WEMCO®

**Weir Specialty Pumps (WEMCO)**  
Salt Lake City, UT  
801-359-8731 • Fax: 801-530-7828  
wemco@mail.weir  
www.global.weir

**Zoeller Pump Company**  
Louisville, KY  
800-928-7867 • 502-778-2731  
www.zoeller.com

## Rectangular Collectors

**AMWELL, A Div. of McNish Corp.**  
Aurora, IL  
630-898-6900 • Fax: 630-898-1647  
phaizman@amwell-inc.com  
www.amwell-inc.com

## Rehab/Retrofit

**Evoqua Water Technologies LLC**  
Warrendale, PA  
800-466-7873 • 724-772-0044  
municipalmarketing@evoqua.com  
www.evoqua.com

## Remote Monitoring



**PRIMEX**  
Detroit Lakes, MN  
888-342-5753 • 218-847-1317 • Fax: 218-847-4617  
info@primexcontrols.com  
www.primexcontrols.com

## Renewable Energy Products

**Amiad USA**  
Mooresville, NC  
704-662-3133 • Fax: 704-662-3155  
info@amiad.com  
www.amiadusa.com

**CNP-Technology Water and Biosolids Corp.**  
Kenosha, WI  
262-764-3651 • Fax: 262-764-8705  
info@cnp-tec.com  
www.cnp-tec.com  
**Ad on page 85**

**Flottweg Separation Technology, Inc.**  
Independence, KY  
859-448-2331 • Fax: 859-448-2333  
sales@flottweg.net  
www.flottweg.com

**Geomembrane Technologies Inc.**  
Fredericton, NB  
Canada  
855-484-4630 • 506-452-7304 • Fax: 506-452-6625  
covers@gticcovers.com  
www.gticcovers.com

**Ovivo USA, LLC**  
Austin, TX  
512-834-6000 • Fax: 512-834-6039  
info.us@ovivowater.com  
www.ovivowater.com

**Permastore**  
Suffolk  
England  
011 44 1379870723  
sales@permastore.com  
www.permastore.com

**Phoenix Contact**  
Middletown, PA  
800-888-7388 • 717-944-1300  
info@phoenixcon.com  
www.phoenixcontact.com/usa\_home

**Sierra Instruments, Inc.**  
Monterey, CA  
800-866-0200 • 831-373-0200 • Fax: 831-373-4402  
info@sierrainstruments.com  
www.sierrainstruments.com

**Unison Solutions, Inc.**  
Dubuque, IA  
563-585-0967 • Fax: 563-585-0970  
sales@unisonsolutions.com  
www.unisonsolutions.com

**Vaughan Company, Inc.**  
Montesano, WA  
888-249-2467 • 360-249-4042 • Fax: 360-249-6155  
info@chopperpumps.com  
www.chopperpumps.com  
**Ad on page 120**

**Westech Engineering**  
Salt Lake City, UT  
801-265-1000 • Fax: 801-265-1080  
info@westech-inc.com  
www.westech-inc.com

## Rental Equipment

**Aeration Industries International**  
Chaska, MN  
800-328-8287 • 952-448-6789 • Fax: 952-448-7293  
aii@aireo2.com  
www.aireo2.com

**Aqua-Aerobic Systems, Inc.**  
Loves Park, IL  
800-940-5008 • 815-654-2501 • Fax: 815-654-2508  
solutions@aqua-aerobic.com  
www.aqua-aerobic.com  
**Ad on page 11**

**Centrisys Corporation**  
Kenosha, WI  
262-654-6006 • Fax: 262-764-8705  
info@centrisys.us  
www.centrisys.com  
**Ad on page 81**

**Mud Cat, Division of Ellicott Dredge Technologies**  
New Richmond, WI  
866-467-4010 • 913-642-5100 • Fax: 913-642-5119  
sales@mudcatdredge.com  
www.mudcatdredge.com



**SRS Crisafulli, Inc.**  
Glendive, MT  
800-442-7867 • 406-365-3393 • Fax: 406-365-8088  
srs@crisafulli.com  
www.crisafullipumps.com

## Sunbelt Rentals

Fort Mill, SC  
800-736-2504  
www.sunbeltrentals.com

Ad on page 27

## Reverse Osmosis Equipment

### AdEdge Water Technologies, LLC

Duluth, GA  
866-823-3343 • 678-835-0052 • Fax: 678-835-0057  
sales@adedgetechnologies.com  
www.adedgetech.com

Ad on page 25

### KCH Engineered Systems

Forest City, NC  
828-245-9836  
khan@kchservices.com  
www.kchservices.com

### Pick Heaters, Inc.

West Bend, WI  
262-338-1191 • Fax: 262-338-8489  
info1@pickheaters.com  
www.pickheaters.com

### Sulzer Pumps Solutions Inc.

Meriden, CT  
800-525-7790 • 203-238-2700 • Fax: 203-238-0738  
info.abs.usa@sulzer.com  
www.sulzer.com

## Root Control

### NozzTeq Inc.

Clearwater, FL  
866-620-5915 • 727-223-4979 • Fax: 603-413-6744  
info@nozzteq.com  
www.nozzteq.com



### RootX

Salem, OR  
800-844-4974 • 503-364-2999 • Fax: 503-485-5229  
rootx@rootx.com  
www.rootx.com

## Rotary Press



### Fournier Industries, Inc.

Theftord Mines, QC  
Canada  
418-423-4241 • 941-757-7201 • Fax: 418-423-7366  
f.caouette@fournierindustries.com  
www.rotary-press.com

Ad on page 91

**Schwing Bioset, Inc.**  
Somerset, WI  
844-246-7381 • 715-247-3433 • Fax: 715-247-3438  
marketing@schwingbioset.com  
www.schwingbioset.com

## Rotating Biological Contactors

### Walker Process Equipment, A Div. of McNish Corp.

Aurora, IL  
800-992-5537 • 630-892-7921 • Fax: 630-892-7951  
walker.process@walker-process.com  
www.walker-process.com

Ad on page 87

## Safety Equipment/Personal Protection Products

### American Pleasure Products, Inc.

Rose City, MI  
989-685-2697 • Fax: 989-685-8484  
info@aquacycleusa.com  
www.aquacycleusa.com

Ad on page 77

### ElectroSwitch Corporation

Weymouth, MA  
781-335-5200  
info@electroswitch.com  
www.electroswitch.com

### ENMET

Ann Arbor, MI  
800-521-2978 • 734-761-1270 • Fax: 734-761-3220  
info@enmet.com  
www.enmet.com

### Fibergrate Composite Structures

Dallas, TX  
800-527-4043 • 972-250-1633 • Fax: 972-250-1530  
info@fibergrate.com  
www.fibergrate.com

### Ford Hall Company, Inc.

Richmond, KY  
859-624-1077 • Fax: 859-624-3320  
sperry@fordhall.com  
www.weir-wolf.com

Ad on page 79

### GillTrading.com, Inc./WeirWasher, ACS

Beaverton, OR  
866-447-2496 • 503-628-0197 • Fax: 503-646-9293  
brentgill@gilltrading.com  
www.gilltrading.com

### Glasdon, Inc.

Sandston, VA  
855-874-5273 • 804-726-3777 • Fax: 804-726-3778  
inquiries@glasdon.com  
www.us.glasdon.com

### Halogen Valve Systems, Inc.

Irvine, CA  
949-261-5030 • Fax: 949-261-5033  
info@halogenvulve.com  
www.halogenvulve.com

### HEMCO Corporation

Independence, MO  
800-779-4362 • 816-796-2900 • Fax: 816-796-3333  
info@hemcocorp.com  
www.hemcocorp.com

Ad on page 117

### Industrial Scientific

Pittsburgh, PA  
412-788-4353 • Fax: 412-788-8353  
info@indsci.com  
www.indsci.com



### Kee Safety, Inc.

Buffalo, NY  
800-851-5181 • 716-896-4949 • Fax: 716-896-5696  
info@keesafety.com  
www.keesafety.com

### Milwaukee Rubber Products, Inc.

Menomonee Falls, WI  
800-325-3730 • 262-781-7888 • Fax: 262-781-1742  
sales@milwaukeeerubber.com  
www.milwaukeeerubber.com

### RKI Instruments, Inc.

Union City, CA  
800-754-5165 • 510-441-5656 • Fax: 510-441-5650  
orders@rkiinstruments.com  
www.rkiinstruments.com

### ScreenCo Systems LLC

Genesee, ID  
208-790-8770  
sales@screenecosystems.com  
www.screenecosystems.com

Ad on page 116

### Uticom Systems, Inc.

Coatesville, PA  
800-548-5321 • 610-857-2655 • Fax: 610-857-2986  
graphics@uticom.net  
www.uticom.net

## Samplers/Sampling Systems

### Hach

Loveland, CO  
800-227-4224 • 970-669-3050  
orders@hach.com  
www.hach.com

Ad on page 5

### Nasco Whirl-Pak

Fort Atkinson, WI  
800-558-9595 • 920-568-5578 • Fax: 920-568-5778  
info@enasco.com  
www.enasco.com/whirlpak

Ad on page 117

## SCADA Systems

### Data Flow Systems, Inc.

Melbourne, FL  
321-259-5009 • Fax: 321-259-4006  
info@dataflowsys.com  
www.dataflowsys.com

### ElectroSwitch Corporation

Weymouth, MA  
781-335-5200  
info@electroswitch.com  
www.electroswitch.com



### Emerson Automation Solutions

Pittsburgh, PA  
800-445-9723 • 412-963-4000  
powerwater@emerson.com  
www.emerson.com/water

### Flomatic Valves

Glens Falls, NY  
800-833-2040 • 518-761-9797 • Fax: 518-761-9798  
flomatic@flomatic.com  
www.flomatic.com

### Phoenix Contact

Middletown, PA  
800-888-7388 • 717-944-1300  
info@phoenixcon.com  
www.phoenixcontact.com/usa\_home



### PRIMEX

Detroit Lakes, MN  
888-342-5753 • 218-847-1317 • Fax: 218-847-4617  
info@primexcontrols.com  
www.primexcontrols.com

### Sensaphone

Aston, PA  
877-373-2700 • 610-558-2700 • Fax: 610-558-0222  
contact@sensaphone.com  
www.sensaphone.com

### Trihedral Engineering Limited

Bedford, NS  
Canada  
800-463-2783 • 902-835-1575 • Fax: 902-835-0369  
pcooke@trihedral.com  
www.trihedral.com

## Scales

### Eagle Microsystems, Inc.

Pottstown, PA  
800-780-8636 • 610-323-2250 • Fax: 610-323-0114  
info@eaglemicrosystems.com  
www.eaglemicrosystems.com



### Force Flow

Concord, CA  
800-893-6723 • 925-686-6700 • Fax: 925-686-6713  
info@forceflow.com  
www.forceflow.com

Ad on page 89

## Screens/Strainers/Screening Systems

### Amiad USA

Moorestville, NC  
704-662-3133 • Fax: 704-662-3155  
info@amiad.com  
www.amiadusa.com

**AMWELL, A Div. of McNish Corp.**  
Aurora, IL  
630-898-6900 • Fax: 630-898-1647  
phaizman@amwell-inc.com  
www.amwell-inc.com

**Aqseptence Group Inc.**  
New Brighton, MN  
800-833-9473 • 651-636-3900 • Fax: 651-638-3171  
matthew.bentley@aqseptence.com  
www.johnsonscreens.com

**Aqualitec Corp.**  
Los Angeles, CA  
855-650-2214  
info@aqualitec.com  
www.aqualitec.com



**CleanTek Water Solutions**  
Fridley, MN  
866-929-7773  
info@cleantekwater.com  
www.cleantekwater.com



**DRYCAKE**  
Vancouver, BC  
Canada  
877-379-2253 • 604-535-2238  
sales@drycake.com  
www.drycake.com



**Duramax Cast Stainless Steel Chain & Equipment Products**  
Pewaukee, WI  
800-691-0998 • 262-691-0998 • Fax: 262-691-0992  
www.duramaxchain.com



**Enviro-Care Company**  
A WAMGROUP® Company  
Gurnee, IL  
815-636-8306 • Fax: 847-672-7968  
esales@enviro-care.com  
www.enviro-care.com  
**Ad on page 59**

**GillTrading.com, Inc./WeirWasher, ACS**  
Beaverton, OR  
866-447-2496 • 503-628-0197 • Fax: 503-646-9293  
brentgill@gilltrading.com  
www.gilltrading.com

**Headworks International, Inc.**  
Houston, TX  
713-647-6667 • Fax: 713-647-0999  
hw@headworksintl.com  
www.headworksintl.com

**Huber Technology, Inc.**  
Huntersville, NC  
704-949-1010 • Fax: 704-949-1020  
marketing@hhusa.net  
www.huberforum.net  
**Ad on page 9**

**Hydro International**  
Hillsboro, OR  
866-615-8130 • 503-615-8130 • Fax: 503-615-2906  
questions@hydro-int.com  
www.hydro-int.com  
**Ad on page 63**

**JDV Equipment Corporation**  
Dover, NJ  
973-366-6556 • Fax: 973-366-3193  
sales@jdvequipment.com  
www.jdvequipment.com  
**Ad on page 83**



**“Cleaner Water for a Brighter Future”**  
**Lakeside Equipment Corporation**  
Bartlett, IL  
630-837-5640 • Fax: 630-837-5647  
sales@lakeside-equipment.com  
www.lakeside-equipment.com  
**Ad on page 3**



**Ovivo USA, LLC**  
Austin, TX  
512-834-6000 • Fax: 512-834-6039  
info.us@ovivowater.com  
www.ovivowater.com

**Park Process**  
Houston, TX  
855-511-7275 • 713-849-7189 • Fax: 713-937-4254  
rcaughman@parkprocess.com  
www.parkprocess.com  
**Ad on page 116**

**Parkson Corporation**  
Ft. Lauderdale, FL  
888-727-5766 • Fax: 954-974-6182  
technology@parkson.com  
www.parkson.com

**Paxxo**  
Newnan, GA  
770-502-0055 • Fax: 770-502-0088  
chris.pettigrew@paxxo.com  
www.paxxo.com

**ScreenCo Systems LLC**  
Geneseo, ID  
208-790-8770  
sales@screencosystems.com  
www.screencosystems.com  
**Ad on page 116**

**Smith & Loveless, Inc.**  
Lenexa, KS  
800-898-9122 • 913-888-5201  
answers@smithandloveless.com  
www.smithandloveless.com

**Sure Flow Products, LLC**  
Wixom, MI  
248-380-3569 • Fax: 248-380-3568  
sales@sureflowproducts.com  
www.flowmetersource.com

## Screw Conveyors

**AMWELL, A Div. of McNish Corp.**  
Aurora, IL  
630-898-6900 • Fax: 630-898-1647  
phaizman@amwell-inc.com  
www.amwell-inc.com

**Aqseptence Group Inc.**  
New Brighton, MN  
800-833-9473 • 651-636-3900 • Fax: 651-638-3171  
matthew.bentley@aqseptence.com  
www.johnsonscreens.com

**Charter Machine Company**  
Metuchen, NJ  
732-548-4400  
walterk@chartermachine.com  
www.chartermachine.com

**CleanTek Water Solutions**  
Fridley, MN  
866-929-7773  
info@cleantekwater.com  
www.cleantekwater.com

**DRYCAKE**  
Vancouver, BC  
Canada  
877-379-2253 • 604-535-2238  
sales@drycake.com  
www.drycake.com

**Garland Manufacturing Company**  
Saco, ME  
800-727-1900 • 207-283-3693 • Fax: 207-283-4834  
wastewater@garlandmfg.com  
www.garlandmfg.com/plastics/wastewater.html  
**Ad on page 89**

**Headworks International, Inc.**  
Houston, TX  
713-647-6667 • Fax: 713-647-0999  
hw@headworksintl.com  
www.headworksintl.com

**Huber Technology, Inc.**  
Huntersville, NC  
704-949-1010 • Fax: 704-949-1020  
marketing@hhusa.net  
www.huberforum.net  
**Ad on page 9**

**JDV Equipment Corporation**  
Dover, NJ  
973-366-6556 • Fax: 973-366-3193  
sales@jdvequipment.com  
www.jdvequipment.com  
**Ad on page 83**

**Lakeside Equipment Corporation**  
Bartlett, IL  
630-837-5640 • Fax: 630-837-5647  
sales@lakeside-equipment.com  
www.lakeside-equipment.com  
**Ad on page 3**

**Paxxo**  
Newnan, GA  
770-502-0055 • Fax: 770-502-0088  
chris.pettigrew@paxxo.com  
www.paxxo.com

**Schwing Bioset, Inc.**  
Somerset, WI  
844-246-7381 • 715-247-3433 • Fax: 715-247-3438  
marketing@schwingbioset.com  
www.schwingbioset.com

**Smith & Loveless, Inc.**  
Lenexa, KS  
800-898-9122 • 913-888-5201  
answers@smithandloveless.com  
www.smithandloveless.com

## Scrubbers/Biofilters

**AdEdge Water Technologies, LLC**  
Duluth, GA  
866-823-3343 • 678-835-0052 • Fax: 678-835-0057  
sales@adedge technologies.com  
www.adedgetech.com  
**Ad on page 25**

**BioAir Solutions LLC**  
Voorhees, NJ  
856-258-6969 • Fax: 856-258-6975  
cwest@bioairsolutions.com  
www.bioairsolutions.com



**BOHN BIOFILTER**  
Tucson, AZ  
520-624-4644  
info@bohnbiofilter.com  
www.bohnbiofilter.com

**Bradley Innovation Group**  
Indianapolis, IN  
317-726-6615  
sales@big-h2o.com  
www.big-h2o.com

**Indusco Environmental Services, Inc.**  
Spanish Fort, AL  
251-621-2338  
sales@induscoenviro.com  
www.induscoenviro.com

**KCH Engineered Systems**  
Forest City, NC  
828-245-9836  
khankinson@kchservices.com  
www.kchservices.com

**Premier Tech Aqua**  
Riviere-du-Loup, QC  
Canada  
800-632-6356 • 418-867-8883 • Fax: 418-862-6642  
pta@premiertech.com  
www.premiertechaqua.com



**Varec Biogas**  
Huntington Beach, CA  
866-424-6427 • Fax: 714-952-2701  
info@varec-biogas.com  
www.varec-biogas.com

## Secondary Containment

**AmTech Tank Lining & Repair**  
Plymouth, NH  
888-839-0373 • Fax: 603-947-9500  
info@amtechtanklining.com  
www.amtechtanklining.com  
**Ad on page 91**

## Sensors

**BinMaster Level Controls**  
Lincoln, NE  
800-278-4241 • 402-434-9102 • Fax: 402-434-9133  
info@binmaster.com  
www.binmaster.com  
**Ad on page 117**



**Chromalox**  
Pittsburgh, PA  
800-443-2640 • 412-967-3800 • Fax: 412-967-5148  
sales@chromalox.com  
www.chromalox.com



**Delta M Corporation**  
Oak Ridge, TN  
800-922-0083 • 865-483-1569 • Fax: 865-483-1142  
sales@deltamcorp.com  
www.deltamcorp.com

**Eagle Microsystems, Inc.**  
Pottstown, PA  
800-780-8636 • 610-323-2250 • Fax: 610-323-0114  
info@eaglemicrosystems.com  
www.eaglemicrosystems.com



**Emerson / Rosemount**  
Shakopee, MN  
800-854-8257 • 952-906-8888  
liquid.csc@emerson.com  
www.rosemount.com

## Endress+Hauser

**Endress+Hauser**  
Greenwood, IN  
888-363-7377 • Fax: 317-535-8498  
info@us.endress.com  
www.us.endress.com

**EnviroSuite**  
Burlingame, CA  
424-335-1331  
inquiries@envirosuite.com  
www.envirosuite.com

**FCI - Fluid Components International**  
San Marcos, CA  
800-854-1993 • 760-744-6950 • Fax: 760-736-6250  
eflow@fluidcomponents.com  
www.fluidcomponents.com

**Force Flow**  
Concord, CA  
800-893-6723 • 925-686-6700 • Fax: 925-686-6713  
info@forceflow.com  
www.forceflow.com  
**Ad on page 89**

**Hach**  
Loveland, CO  
800-227-4224 • 970-669-3050  
orders@hach.com  
www.hach.com  
**Ad on page 5**

**Harwil Corp.**  
Oxnard, CA  
805-988-6800 • Fax: 805-988-6804  
sales@harwil.com  
www.harwil.com

**Hawk Measurement**  
Lawrence, MA  
888-429-5538 • 978-304-3000 • Fax: 978-304-1462  
info@hawkmeasure.com  
www.hawkmeasure.com

**Industrial Scientific**  
Pittsburgh, PA  
412-788-4353 • Fax: 412-788-8353  
info@indsci.com  
www.indsci.com

**IWAKI America**  
Holliston, MA  
508-429-1440  
info@iwakiamerica.com  
www.iwakiamerica.com

**Keller America Inc.**  
Newport News, VA  
877-253-5537 • 757-596-6680 • Fax: 757-596-6659  
sales@kelleramerica.com  
www.kelleramerica.com  
**Ad on page 7**

**LaMotte Company**  
Chestertown, MD  
800-344-3100 • 410-778-3100 • Fax: 410-778-6394  
mkt@lamotte.com  
www.lamotte.com

**MoistTech Corp.**  
Sarasota, FL  
941-351-7870  
www.moisttech.com/

**MYRON L COMPANY**  
Myron L Company  
Carlsbad, CA  
760-438-2021 • Fax: 760-931-9189  
info@myronl.com  
www.myronl.com  
**Ad on page 57**

**PMC Engineering**  
Danbury, CT  
203-792-8686 • Fax: 203-743-2051  
sales@pmc1.com  
www.pmc1.com

**PRIMEX**  
Detroit Lakes, MN  
888-342-5753 • 218-847-1317 • Fax: 218-847-4617  
info@primexcontrols.com  
www.primexcontrols.com

**ProMinent Fluid Controls, Inc.**  
Pittsburgh, PA  
412-787-2484 • Fax: 412-787-0704  
sales@prominent.us  
www.prominent.us

**RKI Instruments, Inc.**  
Union City, CA  
800-754-5165 • 510-441-5656 • Fax: 510-441-5650  
orders@rkiinstruments.com  
www.rkiinstruments.com

**Sensaphone**  
Aston, PA  
877-373-2700 • 610-558-2700 • Fax: 610-558-0222  
contact@sensaphone.com  
www.sensaphone.com

**Sensorex**  
Garden Grove, CA  
800-835-4344 • 714-895-4344  
sales@sensorex.com  
www.sensorex.com

**Sierra Instruments, Inc.**  
Monterey, CA  
800-866-0200 • 831-373-0200 • Fax: 831-373-4402  
info@sierrainstruments.com  
www.sierrainstruments.com

**Sure Flow Products, LLC**  
Wixom, MI  
248-380-3569 • Fax: 248-380-3568  
sales@sureflowproducts.com  
www.flowmetersource.com

**Van London Co.**  
Houston, TX  
800-522-7920 • 832-456-6641 • Fax: 832-456-6642  
anna@vanlondon.com  
www.vanlondon.com

## Septage Receiving Stations

**Bio-Microbics, Inc.**  
Shawnee, KS  
800-753-3278 • 913-422-0707 • Fax: 913-422-0808  
sales@biomicrobics.com  
www.biomicrobics.com

**CleanTek Water Solutions**  
Fridley, MN  
866-929-7773  
info@cleantekwater.com  
www.cleantekwater.com



**DRYCAKE**  
Vancouver, BC  
Canada  
877-379-2253 • 604-535-2238  
sales@drycake.com  
www.drycake.com



**Enviro-Care Company**  
Gurnee, IL  
815-636-8306 • Fax: 847-672-7968  
ecsales@enviro-care.com  
www.enviro-care.com  
**Ad on page 59**

**Huber Technology, Inc.**  
Huntersville, NC  
704-949-1010 • Fax: 704-949-1020  
marketing@hhusa.net  
www.huberforum.net  
**Ad on page 9**

**JDV Equipment Corporation**  
Dover, NJ  
973-366-6556 • Fax: 973-366-3193  
sales@jdvequipment.com  
www.jdvequipment.com  
**Ad on page 83**



**Cleaner Water for a Brighter Future®**  
**Lakeside Equipment Corporation**  
Bartlett, IL  
630-837-5640 • Fax: 630-837-5647  
sales@lakeside-equipment.com  
www.lakeside-equipment.com  
**Ad on page 3**

**LANXESS / International Dioxide, Inc.**  
North Kingstown, RI  
401-295-8800 • Fax: 401-295-7108  
adox@lanxess.com  
www.lanxess.com

**Park Process**  
Houston, TX  
855-511-7275 • 713-849-7189 • Fax: 713-937-4254  
rcoughman@parkprocess.com  
www.parkprocess.com  
**Ad on page 116**



**ScreenCo Systems LLC**  
Genesee, ID  
208-790-8770  
sales@screencosystems.com  
www.screencosystems.com  
**Ad on page 116**

**Smith & Loveless, Inc.**  
Lenexa, KS  
800-898-9122 • 913-888-5201  
answers@smithandloveless.com  
www.smithandloveless.com

**Vaughan Company, Inc.**  
Montesano, WA  
888-249-2467 • 360-249-4042 • Fax: 360-249-6155  
info@chopperpumps.com  
www.chopperpumps.com  
**Ad on page 120**

## Sequencing Batch Reactors (SBR)

**Aeration Industries International**  
Chaska, MN  
800-328-8287 • 952-448-6789 • Fax: 952-448-7293  
aii@aireo2.com  
www.aireo2.com

**Alfa Laval Inc.**  
Richmond, VA  
866-253-2528  
customerservice.usa@alfalaval.com  
www.alfalaval.us

**Aqua Operations, Inc.**  
Bakersfield, CA  
888-746-6535 • 661-331-1181 • Fax: 661-833-1861  
childerbrand@aquaooperations.com  
www.aquaooperations.com



**Aqua-Aerobic Systems, Inc.**  
Loves Park, IL  
800-940-5008 • 815-654-2501 • Fax: 815-654-2508  
solutions@aquaaerobic.com  
www.aquaaerobic.com  
**Ad on page 11**

**Enterprise Specialty Products**  
Laurens, SC  
864-984-7700 • Fax: 864-984-2241  
www.enterprisesp.com

**Evoqua Water Technologies LLC**  
Warrendale, PA  
800-466-7873 • 724-772-0044  
municipalmarketing@evoqua.com  
www.evoqua.com

**F & V Operations and Resource Management**  
Grand Rapids, MI  
888-773-8806 • 616-588-2900 • Fax: 616-977-1005  
bselover@fv-operations.com  
www.fv-operations.com

**Fluidyne Corporation**  
Cedar Falls, IA  
319-266-9967 • Fax: 319-277-6034  
fluidyne@fluidynecorp.com  
www.fluidynecorp.com



**Cleaner Water for a Brighter Future®**  
**Lakeside Equipment Corporation**  
Bartlett, IL  
630-837-5640 • Fax: 630-837-5647  
sales@lakeside-equipment.com  
www.lakeside-equipment.com  
**Ad on page 3**

**Ovivo USA, LLC**  
Austin, TX  
512-834-6000 • Fax: 512-834-6039  
info.us@ovivowater.com  
www.ovivowater.com

**Parkson Corporation**  
Ft. Lauderdale, FL  
888-727-5766 • Fax: 954-974-6182  
technology@parkson.com  
www.parkson.com



**Premier Tech Aqua**  
Riviere-du-Loup, QC  
Canada  
800-632-6356 • 418-867-8883 • Fax: 418-862-6642  
pta@premiertech.com  
www.premiertechaqua.com

## Service Company

**Activated Carbon Services - PACS**  
Coraopolis, PA  
800-367-2587 • 724-457-6576  
henry@pacslabs.com  
www.pacslabs.com

**CEI - Carbon Enterprises Inc.**  
Circleville, OH  
800-344-5770 • Fax: 888-204-9656  
info@ceicompanies.com  
www.ceifiltration.com

**Centrisys Corporation**  
Kenosha, WI  
262-654-6006 • Fax: 262-764-8705  
info@centrisys.us  
www.centrisys.com  
**Ad on page 81**

**CNP-Technology Water and Biosolids Corp.**  
Kenosha, WI  
262-764-3651 • Fax: 262-764-8705  
info@cnp-tec.com  
www.cnp-tec.com  
**Ad on page 85**

**F & V Operations and Resource Management**  
Grand Rapids, MI  
888-773-8806 • 616-588-2900 • Fax: 616-977-1005  
bselover@fv-operations.com  
www.fv-operations.com

**JPCI Services**  
Mesa, AZ  
480-986-1212  
info@jpciservices.com  
www.jpciservices.com

**Rebuild-It Service Group, LLC**  
Midvale, UT  
888-709-5676 • Fax: 385-355-6989  
treburn@rebuild-it.com  
www.rebuild-it.com

**U.S. Submergent Technologies LLC**  
Sarasota, FL  
844-765-7866 • 941-444-1440 • Fax: 941-219-3080  
info@ussubmergent.com  
www.ussubmergent.com

**U.S. Water Services Corporation**  
New Port Richey, FL  
866-753-8292 • 515-269-2336 • Fax: 727-848-7701  
info@uswatercorp.net  
www.uswatercorp.com

## Sight Flow Indicators

**Sure Flow Products, LLC**  
Wixom, MI  
248-380-3569 • Fax: 248-380-3568  
sales@sureflowproducts.com  
www.flowmetersource.com

## Skimmers

**AMWELL, A Div. of McNish Corp.**  
Aurora, IL  
630-898-6900 • Fax: 630-898-1647  
phaizman@amwell-inc.com  
www.amwell-inc.com

**Park Process**  
Houston, TX  
855-511-7275 • 713-849-7189 • Fax: 713-937-4254  
rcaughman@parkprocess.com  
www.parkprocess.com  
**Ad on page 116**

**Rebuild-It Service Group, LLC**  
Midvale, UT  
888-709-5676 • Fax: 385-355-6989  
treburn@rebuild-it.com  
www.rebuild-it.com

## Sludge - Collectors/ Measurement

**AMWELL, A Div. of McNish Corp.**  
Aurora, IL  
630-898-6900 • Fax: 630-898-1647  
phaizman@amwell-inc.com  
www.amwell-inc.com

**Garland Manufacturing Company**  
Saco, ME  
800-727-1900 • 207-283-3693 • Fax: 207-283-4834  
wastewater@garlandmfg.com  
www.garlandmfg.com/plastics/wastewater.html  
**Ad on page 89**

**Hawk Measurement**  
Lawrence, MA  
888-429-5538 • 978-304-3000 • Fax: 978-304-1462  
info@hawkmeasure.com  
www.hawkmeasure.com

**Mud Cat, Division of Ellicott Dredge Technologies**  
New Richmond, WI  
866-467-4010 • 913-642-5100 • Fax: 913-642-5119  
sales@mudcatdredge.com  
www.mudcatdredge.com

**Nasco Whirl-Pak**  
Fort Atkinson, WI  
800-558-9595 • 920-568-5578 • Fax: 920-568-5778  
info@enasco.com  
www.enasco.com/whirlpak  
**Ad on page 117**

## Sludge - Dewatering/ Presses

**Alfa Laval Inc.**  
Richmond, VA  
866-253-2528  
customerservice.usa@alfalaval.com  
www.alfalaval.us

**Aqseptence Group Inc.**  
New Brighton, MN  
800-833-9473 • 651-636-3900 • Fax: 651-638-3171  
matthew.bentley@aqseptence.com  
www.johnsonscreeens.com

**Aqualitec Corp.**  
Los Angeles, CA  
855-650-2214  
info@aqualitec.com  
www.aqualitec.com

**BCR Environmental Corporation**  
Jacksonville, FL  
904-819-9170 • Fax: 904-998-3828  
marketing@bcenv.com  
www.bcenv.com

**BDP Industries**  
Greenwich, NY  
518-695-6851 • Fax: 518-695-5417  
dan@bdpindustries.com  
www.bdpindustries.com  
**Ad on page 73**

**Boerger, LLC**  
Chanhausen, MN  
612-435-7300 • Fax: 612-435-7301  
america@boerger.com  
www.boerger.com  
**Ad on page 55**

**Bright Technologies, Division of Sebright Products, Inc.**  
Hopkins, MI  
800-253-0532 • 269-793-7183 • Fax: 269-793-4022  
julie@brightbeltpress.com  
www.brightbeltpress.com  
**Ad on page 83**

**Brown Bear Corporation**  
Corning, IA  
641-322-4220 • Fax: 641-322-3527  
sales@brownbearcorp.com  
www.brownbearcorp.com

**Centrisys Corporation**  
Kenosha, WI  
262-654-6006 • Fax: 262-764-8705  
info@centrisys.us  
www.centrisys.com  
**Ad on page 81**



**Charter Machine Company**  
Metuchen, NJ  
732-548-4400  
walterk@chartermachine.com  
www.chartermachine.com



**DRYCAKE**  
Vancouver, BC  
Canada  
877-379-2253 • 604-535-2238  
sales@drycake.com  
www.drycake.com

**FKC Co., Ltd.**  
Port Angeles, WA  
360-452-9472 • Fax: 360-452-6880  
mail@fkcscrewpress.com  
www.fkcscrewpress.com

**Flottweg Separation Technology, Inc.**  
Independence, KY  
859-448-2331 • Fax: 859-448-2333  
sales@flottweg.net  
www.flottweg.com



**Fournier Industries, Inc.**  
Theftord Mines, QC  
Canada  
418-423-4241 • 941-757-7201 • Fax: 418-423-7366  
f.caouette@fournierindustries.com  
www.rotary-press.com  
**Ad on page 91**

**Garland Manufacturing Company**  
Saco, ME  
800-727-1900 • 207-283-3693 • Fax: 207-283-4834  
wastewater@garlandmfg.com  
www.garlandmfg.com/plastics/wastewater.html  
**Ad on page 89**



**GEA Group**  
Northvale, NJ  
800-722-6622 • 201-767-3900 • Fax: 201-767-3901  
info.wsus@gea.com  
www.gea.com



**Huber Technology, Inc.**  
Huntersville, NC  
704-949-1010 • Fax: 704-949-1020  
marketing@hhusa.net  
www.huberforum.net  
**Ad on page 9**



**Hydra-Tech Pumps**  
Nesquehoning, PA  
570-645-3779 • Fax: 570-645-4061  
htpump@hydra-tech.com  
www.hydra-tech.com

**Hydro International**  
Hillsboro, OR  
866-615-8130 • 503-615-8130 • Fax: 503-615-2906  
questions@hydro-int.com  
www.hydro-int.com

**Ad on page 63**

**JDV Equipment Corporation**  
Dover, NJ  
973-366-6556 • Fax: 973-366-3193  
sales@jdvequipment.com  
www.jdvequipment.com

**Ad on page 83**



**Komline-Sanderson**  
Peapack, NJ  
800-225-5457 • 908-234-1000 • Fax: 908-234-9487  
info@komline.com  
www.komline.com

**Ad on page 69**

**LANXESS / International Dioxide, Inc.**  
North Kingstown, RI  
401-295-8800 • Fax: 401-295-7108  
adox@lanxess.com  
www.lanxess.com

**Mud Cat, Division of Ellicott Dredge Technologies**  
New Richmond, WI  
866-467-4010 • 913-642-5100 • Fax: 913-642-5119  
sales@mudcatdredge.com  
www.mudcatdredge.com



**Ovivo USA, LLC**  
Austin, TX  
512-834-6000 • Fax: 512-834-6039  
info.us@ovivowater.com  
www.ovivowater.com

**Park Process**  
Houston, TX  
855-511-7275 • 713-849-7189 • Fax: 713-937-4254  
rcaughman@parkprocess.com  
www.parkprocess.com

**Ad on page 116**

**Schwing Bioset, Inc.**  
Somerset, WI  
844-246-7381 • 715-247-3433 • Fax: 715-247-3438  
marketing@schwingbioset.com  
www.schwingbioset.com



**Trident Processes LLC**  
Sumas, WA  
800-799-3740 • 604-330-2500  
info@tridentprocesses.com  
www.tridentprocesses.com

**USP Technologies (US Peroxide)**  
Atlanta, GA  
877-346-4262 • 404-352-6070 • Fax: 404-352-6077  
info@usp technologies.com  
www.usptechnologies.com



**VFOLD INC.**  
15700 Robin's Hill Rd., Unit #2  
London, ON N5V 0A4  
Canada  
877-818-3653 • Fax: 519-659-6941  
sales@vfoldinc.com  
www.vfoldinc.com

**Wastewater Depot, LLC**  
Batavia, OH  
513-732-0129 • Fax: 513-735-1485  
info@wastewaterdepot.com  
www.wastewaterdepot.com

**Sludge - Dryers**

**BCR Environmental Corporation**  
Jacksonville, FL  
904-819-9170 • Fax: 904-998-3828  
marketing@bcrenv.com  
www.bcrenv.com

**BDP Industries**  
Greenwich, NY  
518-695-6851 • Fax: 518-695-5417  
dan@bdpindustries.com  
www.bdpindustries.com

**Ad on page 73**

**Brown Bear Corporation**  
Corning, IA  
641-322-4220 • Fax: 641-322-3527  
sales@brownbearcorp.com  
www.brownbearcorp.com

**Centrisys Corporation**  
Kenosha, WI  
262-654-6006 • Fax: 262-764-8705  
info@centrisys.us  
www.centrisys.com

**Ad on page 81**



**DRYCAKE**  
Vancouver, BC  
Canada  
877-379-2253 • 604-535-2238  
sales@drycake.com  
www.drycake.com

**Gryphon Environmental**  
Owensboro, KY  
270-485-2680  
info@2gryphon.com  
www.2gryphon.com

**Huber Technology, Inc.**  
Huntersville, NC  
704-949-1010 • Fax: 704-949-1020  
marketing@hhusa.net  
www.huberforum.net

**Ad on page 9**



**Komline-Sanderson**  
Peapack, NJ  
800-225-5457 • 908-234-1000 • Fax: 908-234-9487  
info@komline.com  
www.komline.com

**Ad on page 69**

**Parkson Corporation**  
Ft. Lauderdale, FL  
888-727-5766 • Fax: 954-974-6182  
technology@parkson.com  
www.parkson.com

**Schwing Bioset, Inc.**  
Somerset, WI  
844-246-7381 • 715-247-3433 • Fax: 715-247-3438  
marketing@schwingbioset.com  
www.schwingbioset.com

**Sludge - Hauling/Disposal**

**BCR Environmental Corporation**  
Jacksonville, FL  
904-819-9170 • Fax: 904-998-3828  
marketing@bcrenv.com  
www.bcrenv.com

**Kuhn North America, Inc.**  
Brodhead, WI  
608-897-2131 • Fax: 608-897-2561  
chris.searles@kuhn.com  
www.kuhnnorthamerica.com

**Ad on page 8**

**Schwing Bioset, Inc.**  
Somerset, WI  
844-246-7381 • 715-247-3433 • Fax: 715-247-3438  
marketing@schwingbioset.com  
www.schwingbioset.com

**Sludge - Heaters**

**CleanTek Water Solutions**  
Fridley, MN  
866-929-7773  
info@cleantekwater.com  
www.cleantekwater.com



**HRS HEAT EXCHANGERS**  
Marietta, GA  
770-726-3540  
info@hrs-heatexchangers.com  
www.hrs-heatexchangers.com

**Sludge - Hydrolysis**

**CNP-Technology Water and Biosolids Corp.**  
Kenosha, WI  
262-764-3651 • Fax: 262-764-8705  
info@cnp-tec.com  
www.cnp-tec.com

**Ad on page 85**

**Sludge - Land Application**

**Schwing Bioset, Inc.**  
Somerset, WI  
844-246-7381 • 715-247-3433 • Fax: 715-247-3438  
marketing@schwingbioset.com  
www.schwingbioset.com

**Sludge - Mixers/Thickeners**

**Aeration Industries International**  
Chaska, MN  
800-328-8287 • 952-448-6789 • Fax: 952-448-7293  
aia@aireo2.com  
www.aireo2.com

**Alfa Laval Inc.**  
Richmond, VA  
866-253-2528  
customerservice.usa@alfalaval.com  
www.alfalaval.us

**AMWELL, A Div. of McNish Corp.**  
Aurora, IL  
630-898-6900 • Fax: 630-898-1647  
phaizman@amwell-inc.com  
www.amwell-inc.com

**Aqseptence Group Inc.**  
New Brighton, MN  
800-833-9473 • 651-636-3900 • Fax: 651-638-3171  
matthew.bentley@aqseptence.com  
www.johnsonscreens.com

**AQUATURBO SYSTEMS, Inc.**  
Springdale, AR  
479-927-1300 • Fax: 479-927-0700  
ats@aquaturbo.com  
www.aquaturbousa.com

**BDP Industries**  
Greenwich, NY  
518-695-6851 • Fax: 518-695-5417  
dan@bdpindustries.com  
www.bdpindustries.com

**Ad on page 73**

**Brown Bear Corporation**  
Corning, IA  
641-322-4220 • Fax: 641-322-3527  
sales@brownbearcorp.com  
www.brownbearcorp.com

**Centrisys Corporation**  
Kenosha, WI  
262-654-6006 • Fax: 262-764-8705  
info@centrisys.us  
www.centrisys.com

**Ad on page 81**

**Charter Machine Company**  
Metuchen, NJ  
732-548-4400  
walterk@chartermachine.com  
www.chartermachine.com

**CleanTek Water Solutions**  
Fridley, MN  
866-929-7773  
info@cleantekwater.com  
www.cleantekwater.com

**DRYCAKE**  
Vancouver, BC  
Canada  
877-379-2253 • 604-535-2238  
sales@drycake.com  
www.drycake.com

**FKC Co., Ltd.**  
Port Angeles, WA  
360-452-9472 • Fax: 360-452-6880  
mail@fkcscrewpress.com  
www.fkcscrewpress.com

**Huber Technology, Inc.**  
Huntersville, NC  
704-949-1010 • Fax: 704-949-1020  
marketing@hhusa.net  
www.huberforum.net  
**Ad on page 9**

**JDV Equipment Corporation**  
Dover, NJ  
973-366-6556 • Fax: 973-366-3193  
sales@jdvequipment.com  
www.jdvequipment.com  
**Ad on page 83**

 **Komline-Sanderson**  
Peapack, NJ  
800-225-5457 • 908-234-1000 • Fax: 908-234-9487  
info@komline.com  
www.komline.com  
**Ad on page 69**

**KSB, Inc.**  
Henrico, VA  
800-945-7867 • 804-222-1818 • Fax: 804-226-6961  
sales@ksbusa.com  
www.ksbusa.com

**Kuhn North America, Inc.**  
Brodhead, WI  
608-897-2131 • Fax: 608-897-2561  
chris.searles@kuhn.com  
www.kuhnnorthamerica.com  
**Ad on page 8**

 **OVIVO**  
Bringing water to life  
**Ovivo USA, LLC**  
Austin, TX  
512-834-6000 • Fax: 512-834-6039  
info.us@ovivowater.com  
www.ovivowater.com

**Parkson Corporation**  
Ft. Lauderdale, FL  
888-727-5766 • Fax: 954-974-6182  
technology@parkson.com  
www.parkson.com

**Pulsed Hydraulics, Inc.**  
Oroville, WA  
800-641-1726 • 425-785-3225  
info@phiwater.com  
www.phiwater.com  
**Ad on page 116**

**Rebuild-It Service Group, LLC**  
Midvale, UT  
888-709-5676 • Fax: 385-355-6989  
treburn@rebuild-it.com  
www.rebuild-it.com

**ScreenCo Systems LLC**  
Genesee, ID  
208-790-8770  
sales@screenco.com  
www.screenco.com  
**Ad on page 116**

**Smith & Loveless, Inc.**  
Lenexa, KS  
800-898-9122 • 913-888-5201  
answers@smithandloveless.com  
www.smithandloveless.com

**Trident Processes LLC**  
Sumas, WA  
800-799-3740 • 604-330-2500  
info@tridentprocesses.com  
www.tridentprocesses.com

**Vaughan Company, Inc.**  
Montesano, WA  
888-249-2467 • 360-249-4042 • Fax: 360-249-6155  
info@chopperpumps.com  
www.chopperpumps.com  
**Ad on page 120**

**Walker Process Equipment, A Div. of McNish Corp.**  
Aurora, IL  
800-992-5537 • 630-892-7921 • Fax: 630-892-7951  
walker.process@walker-process.com  
www.walker-process.com  
**Ad on page 87**

## Sludge - Screening

**Enviro-Care Company**  
Gurnee, IL  
815-636-8306 • Fax: 847-672-7968  
ecsales@enviro-care.com  
www.enviro-care.com  
**Ad on page 59**

**Huber Technology, Inc.**  
Huntersville, NC  
704-949-1010 • Fax: 704-949-1020  
marketing@hhusa.net  
www.huberforum.net  
**Ad on page 9**

## Sludge Reduction/ Treatment

**Aeration Industries International**  
Chaska, MN  
800-328-8287 • 952-448-6789 • Fax: 952-448-7293  
aii@aireo2.com  
www.aireo2.com

**Airmaster Aerator LLC**  
DeRidder, LA  
888-813-3680 • 337-463-6567 • Fax: 337-463-9119  
deanc@airmasteraerator.com  
www.airmasteraerator.com  
**Ad on page 4**

**Aqualitec Corp.**  
Los Angeles, CA  
855-650-2214  
info@aqualitec.com  
www.aqualitec.com

**BCR Environmental Corporation**  
Jacksonville, FL  
904-819-9170 • Fax: 904-998-3828  
marketing@bcrenv.com  
www.bcrenv.com

**Bionetix International**  
Ste-Anne-de-Bellevue, QC  
Canada  
514-457-2914 • Fax: 514-457-3589  
info@bionetix.ca  
www.bionetix-international.com

**Bradley Innovation Group**  
Indianapolis, IN  
317-726-6615  
sales@big-h2o.com  
www.big-h2o.com

**Bright Technologies, Division of Sebright Products, Inc.**  
Hopkins, MI  
800-253-0532 • 269-793-7183 • Fax: 269-793-4022  
julie@brightbeltpress.com  
www.brightbeltpress.com  
**Ad on page 83**

**Brown Bear Corporation**  
Corning, IA  
641-322-4220 • Fax: 641-322-3527  
sales@brownbearcorp.com  
www.brownbearcorp.com

**Byo-Gon, Inc.**  
Charleston, SC  
888-796-4661 • 843-822-3415 • Fax: 843-606-6318  
info@byogon.com  
www.byogon.com  
**Ad on page 117**

**CNP-Technology Water and Biosolids Corp.**  
Kenosha, WI  
262-764-3651 • Fax: 262-764-8705  
info@cnp-tec.com  
www.cnp-tec.com  
**Ad on page 85**

**Flottweg Separation Technology, Inc.**  
Independence, KY  
859-448-2331 • Fax: 859-448-2333  
sales@flottweg.net  
www.flottweg.com

**Fluidyne Corporation**  
Cedar Falls, IA  
319-266-9967 • Fax: 319-277-6034  
fluidyne@fluidynecorp.com  
www.fluidynecorp.com

 **GREENER PLANET SYSTEMS**  
**Greener Planet Systems**  
Monroe, IA  
888-669-1787 • 517-719-2580  
brianm@greenerplanetsystems.com  
www.greenerplanetsystems.com

**Huber Technology, Inc.**  
Huntersville, NC  
704-949-1010 • Fax: 704-949-1020  
marketing@hhusa.net  
www.huberforum.net  
**Ad on page 9**

**LANXESS / International Dioxide, Inc.**  
North Kingstown, RI  
401-295-8800 • Fax: 401-295-7108  
adox@lanxess.com  
www.lanxess.com

**Mud Cat, Division of Ellicott Dredge Technologies**  
New Richmond, WI  
866-467-4010 • 913-642-5100 • Fax: 913-642-5119  
sales@mudcatdredge.com  
www.mudcatdredge.com

**Ovivo USA, LLC**  
Austin, TX  
512-834-6000 • Fax: 512-834-6039  
info.us@ovivowater.com  
www.ovivowater.com

**Smith & Loveless, Inc.**  
Lenexa, KS  
800-898-9122 • 913-888-5201  
answers@smithandloveless.com  
www.smithandloveless.com

**Trident Processes LLC**  
Sumas, WA  
800-799-3740 • 604-330-2500  
info@tridentprocesses.com  
www.tridentprocesses.com

## Software - Operations/ Maintenance

**AllMax Software, Inc.**  
Kenton, OH  
800-670-1867 • 419-673-8863 • Fax: 419-673-8864  
sales@allmaxsoftware.com  
www.allmaxsoftware.com  
**Ad on page 31**

**BinMaster Level Controls**  
Lincoln, NE  
800-278-4241 • 402-434-9102 • Fax: 402-434-9133  
info@binmaster.com  
www.binmaster.com  
**Ad on page 117**

**Emerson Automation Solutions**  
Pittsburgh, PA  
800-445-9723 • 412-963-4000  
powerwater@emerson.com  
www.emerson.com/water

**EnviroSuite**  
Burlingame, CA  
424-335-1331  
inquiries@envirosuite.com  
www.envirosuite.com

 **Hydromantis**  
Environmental Software Solutions, Inc.  
**Hydromantis Environmental Software Solutions, Inc.**  
Hamilton, ON  
Canada  
905-522-0012 • Fax: 905-522-0031  
info@hydromantis.com  
www.hydromantis.com

**ProComSol, Ltd**  
Lakewood, OH  
877-221-1551 • 216-221-1550 • Fax: 216-221-1554  
sales@procomsol.com  
www.procomsol.com  
**Ad on page 85**

## Software - Process Control/Regulatory

**Activated Carbon Services - PACS**  
Coraopolis, PA  
800-367-2587 • 724-457-6576  
henry@pacslabs.com  
www.pacslabs.com

**AllMax Software, Inc.**  
Kenton, OH  
800-670-1867 • 419-673-8863 • Fax: 419-673-8864  
sales@allmaxsoftware.com  
www.allmaxsoftware.com  
**Ad on page 31**



**Emerson Automation Solutions**  
Pittsburgh, PA  
800-445-9723 • 412-963-4000  
powerwater@emerson.com  
www.emerson.com/water

**EnviroSuite**  
Burlingame, CA  
424-335-1331  
inquiries@envirosuite.com  
www.envirosuite.com

**Hach**  
Loveland, CO  
800-227-4224 • 970-669-3050  
orders@hach.com  
www.hach.com

**Ad on page 5**

**Hydromantis Environmental Software Solutions, Inc.**  
Hamilton, ON  
Canada  
905-522-0012 • Fax: 905-522-0031  
info@hydromantis.com  
www.hydromantis.com

**Trihedral Engineering Limited**  
Bedford, NS  
Canada  
800-463-2783 • 902-835-1575 • Fax: 902-835-0366  
pcooke@trihedral.com  
www.trihedral.com

**WEG Electric Corp**  
Duluth, GA  
800-275-4934  
info-us@weg.net  
www.weg.net/us

## Stormwater Monitoring/ Treatment

**Aqua-Aerobic Systems, Inc.**  
Loves Park, IL  
800-940-5008 • 815-654-2501 • Fax: 815-654-2508  
solutions@aqua-aerobic.com  
www.aqua-aerobic.com



**Bio-Microbics, Inc.**  
Shawnee, KS  
800-753-3278 • 913-422-0707 • Fax: 913-422-0808  
sales@biomicrobics.com  
www.biomicrobics.com

**CHEMetrics, Inc.**  
Midland, VA  
800-356-3072 • 540-788-9026 • Fax: 540-788-4856  
sales@chemetrics.com  
www.chemetrics.com

**Data Flow Systems, Inc.**  
Melbourne, FL  
321-259-5009 • Fax: 321-259-4006  
info@dataflowsys.com  
www.dataflowsys.com

**Deep Trekker Inc.**  
Kitchener, ON  
Canada  
519-342-3177  
sales@deeptrekker.com  
www.deeptrekker.com

**Ad on page 93**

**Duperon Corporation**  
Saginaw, MI  
800-383-8479 • 989-754-8800 • Fax: 989-754-2175  
bbauer@duperon.com  
www.duperon.com

**EnviroSuite**  
Burlingame, CA  
424-335-1331  
inquiries@envirosuite.com  
www.envirosuite.com

**Hydro International**  
Hillsboro, OR  
866-615-8130 • 503-615-8130 • Fax: 503-615-2906  
questions@hydro-int.com  
www.hydro-int.com

**Ad on page 63**

**IWAKI America**  
Holliston, MA  
508-429-1440  
info@iwakiamerica.com  
www.iwakiamerica.com

**Keller America Inc.**  
Newport News, VA  
877-253-5537 • 757-596-6680 • Fax: 757-596-6659  
sales@kelleramerica.com  
www.kelleramerica.com

**Ad on page 7**

**MYRON L COMPANY**  
Myron L Company  
Carlsbad, CA  
760-438-2021 • Fax: 760-931-9189  
info@myronl.com  
www.myronl.com  
**Ad on page 57**

**PMC Engineering**  
Danbury, CT  
203-792-8686 • Fax: 203-743-2051  
sales@pmc1.com  
www.pmc1.com

**Rain for Rent**  
Bakersfield, CA  
800-742-7246 • 661-399-9124  
info@rainforrent.com  
www.rainforrent.com

**Trihedral Engineering Limited**  
Bedford, NS  
Canada  
800-463-2783 • 902-835-1575 • Fax: 902-835-0366  
pcooke@trihedral.com  
www.trihedral.com

## Struvite Removal/Recovery

**CNP-Technology Water and Biosolids Corp.**  
Kenosha, WI  
262-764-3651 • Fax: 262-764-8705  
info@cnp-tec.com  
www.cnp-tec.com

**Ad on page 85**

## Switches/Relays

**ElectroSwitch Corporation**  
Weymouth, MA  
781-335-5200  
info@electroswitch.com  
www.electroswitch.com

**Harwil Corp.**  
Oxnard, CA  
805-988-6800 • Fax: 805-988-6804  
sales@harwil.com  
www.harwil.com

**PRIMEX**  
Detroit Lakes, MN  
888-342-5753 • 218-847-1317 • Fax: 218-847-4617  
info@primexcontrols.com  
www.primexcontrols.com

**Ronk Electrical**  
Nokomis, IL  
800-221-7665 • 217-563-8333 • Fax: 217-563-8336  
sales@ronkelectrical.com  
www.ronkelectrical.com

**Ad on page 116**

**WEG Electric Corp**  
Duluth, GA  
800-275-4934  
info-us@weg.net  
www.weg.net/us

## Tanks - Chemical Storage

**AmTech Tank Lining & Repair**  
Plymouth, NH  
888-839-0373 • Fax: 603-947-9500  
info@amtechtanklining.com  
www.amtechtanklining.com

**Ad on page 91**

**CST Industries, Inc.**  
Kansas City, MO  
913-621-3700  
sales@cstindustries.com  
www.cstindustries.com



**Dragon Products, Ltd.**  
Beaumont, TX  
800-231-8198  
sales@modernusa.com  
www.dragonproductsLtd.com

**Hawkins Water Treatment Group**  
Roseville, MN  
800-328-5460 • 612-331-6910 • Fax: 612-331-5304  
laura.eilek@hawkinsinc.com  
www.hawkinsinc.com

**KCH Engineered Systems**  
Forest City, NC  
828-245-9836  
khankinson@kchservices.com  
www.kchservices.com

**Lutz-JESCO America Corp.**  
Rochester, NY  
800-554-2762 • 585-426-0990 • Fax: 585-426-4025  
mail@jescoamerica.com  
www.lutzjescoamerica.com

**Peabody Engineering and Supply Inc.**  
Corona, CA  
877-734-3759 • Fax: 951-734-4111  
sales@4peabody.com  
www.4peabody.com

**Pittsburg Tank & Tower Co., Inc.**  
Henderson, KY  
270-826-9000 • Fax: 270-827-4417  
pheltsley@watertank.com  
www.watertank.com

**Rhino Linings Corporation**  
San Diego, CA  
800-747-6966 • 858-450-0441 • Fax: 858-450-6881  
sales@rhinolining.com  
www.rhinolining.com

**Ad on page 19**

## Tanks - Cleaning/ Inspection/Repair



**AmTech Tank Lining & Repair**  
Plymouth, NH  
888-839-0373 • Fax: 603-947-9500  
info@amtechtanklining.com  
www.amtechtanklining.com

**Ad on page 91**

**Deep Trekker Inc.**  
Kitchener, ON  
Canada  
519-342-3177  
sales@deeptrekker.com  
www.deeptrekker.com

**Ad on page 93**

**Environmental Coatings LLC**  
Mesa, AZ  
480-984-7608  
info@sewershield.com  
www.sewershield.com

**Ford Hall Company, Inc.**  
Richmond, KY  
859-624-1077 • Fax: 859-624-3320  
sperry@fordhall.com  
www.weir-wolf.com

**Ad on page 79**

**GillTrading.com, Inc./WeirWasher, ACS**  
Beaverton, OR  
866-447-2496 • 503-628-0197 • Fax: 503-646-9293  
brentgill@gilltrading.com  
www.gilltrading.com

**JPCI Services**  
Mesa, AZ  
480-986-1212  
info@jpciservices.com  
www.jpciservices.com

**Permastore**  
Suffolk  
England  
011 44 1379870723  
sales@permastore.com  
www.permastore.com

**Pittsburg Tank & Tower Co., Inc.**  
Henderson, KY  
270-826-9000 • Fax: 270-827-4417  
pheltsley@watertank.com  
www.watertank.com

**Rhino Linings Corporation**

San Deigo, CA  
800-747-6966 • 858-450-0441 • Fax: 858-450-6881  
sales@rhinolinings.com  
www.rhinolinings.com  
**Ad on page 19**

**Superior Tank Co., Inc.**

Rancho Cucamonga, CA  
877-974-4438 • 909-912-0580 • Fax: 909-912-0585  
marketing@superiortank.com  
www.superiortank.com  
**Ad on page 75**

**Tanks - Coatings/Linings**



**AmTech Tank Lining & Repair**

Plymouth, NH  
888-839-0373 • Fax: 603-947-9500  
info@amtechtanklining.com  
www.amtechtanklining.com  
**Ad on page 91**

**CST Industries, Inc.**

Kansas City, MT  
913-621-3700  
sales@cstindustries.com  
www.cstindustries.com

**DRYCAKE**

Vancouver, BC  
Canada  
877-379-2253 • 604-535-2238  
sales@drycake.com  
www.drycake.com

**Environmental Coatings LLC**

Mesa, AZ  
480-984-7608  
info@sewershield.com  
www.sewershield.com

**JPCI Services**

Mesa, AZ  
480-986-1212  
info@jpciservices.com  
www.jpciservices.com

**Pittsburg Tank & Tower Co., Inc.**

Henderson, KY  
270-826-9000 • Fax: 270-827-4417  
pheltsley@watertank.com  
www.watertank.com

**Rhino Linings Corporation**

San Deigo, CA  
800-747-6966 • 858-450-0441 • Fax: 858-450-6881  
sales@rhinolinings.com  
www.rhinolinings.com  
**Ad on page 19**

**Superior Tank Co., Inc.**

Rancho Cucamonga, CA  
877-974-4438 • 909-912-0580 • Fax: 909-912-0585  
marketing@superiortank.com  
www.superiortank.com  
**Ad on page 75**

**Tanks - Mixers**

**AQUATURBO SYSTEMS, Inc.**  
Springdale, AR  
479-927-1300 • Fax: 479-927-0700  
ats@aquaturbo.com  
www.aquaturbousa.com



**Dragon Products, Ltd.**

Beaumont, TX  
800-231-8198  
sales@modernusa.com  
www.dragonproductsltd.com

**DRYCAKE**

Vancouver, BC  
Canada  
877-379-2253 • 604-535-2238  
sales@drycake.com  
www.drycake.com

**JDV Equipment Corporation**

Dover, NJ  
973-366-6556 • Fax: 973-366-3193  
sales@jdvequipment.com  
www.jdvequipment.com  
**Ad on page 83**

**KSB, Inc.**

Henrico, VA  
800-945-7867 • 804-222-1818 • Fax: 804-226-6961  
sales@ksbusa.com  
www.ksbusa.com

**Pittsburg Tank & Tower Co., Inc.**

Henderson, KY  
270-826-9000 • Fax: 270-827-4417  
pheltsley@watertank.com  
www.watertank.com

**Red Valve Co. / Tideflex Technologies**

Carnegie, PA  
412-279-0044 • Fax: 412-279-7878  
sales@redvalve.com  
www.redvalve.com  
**Ad on page 35**

**Vaughan Company, Inc.**

Montesano, WA  
888-249-2467 • 360-249-4042 • Fax: 360-249-6155  
info@chopperpumps.com  
www.chopperpumps.com  
**Ad on page 120**

**Tanks - Pressure**

**AmTech Tank Lining & Repair**

Plymouth, NH  
888-839-0373 • Fax: 603-947-9500  
info@amtechtanklining.com  
www.amtechtanklining.com  
**Ad on page 91**

**Tanks - Storage**



**CST Industries, Inc.**

Kansas City, MT  
913-621-3700  
sales@cstindustries.com  
www.cstindustries.com



**Dragon Products, Ltd.**

Beaumont, TX  
800-231-8198  
sales@modernusa.com  
www.dragonproductsltd.com



**DRYCAKE**

Vancouver, BC  
Canada  
877-379-2253 • 604-535-2238  
sales@drycake.com  
www.drycake.com

**Park Process**

Houston, TX  
855-511-7275 • 713-849-7189 • Fax: 713-937-4254  
rcaughman@parkprocess.com  
www.parkprocess.com  
**Ad on page 116**

**Parker Boiler Co.**

Los Angeles, CA  
323-727-9800 • Fax: 323-722-2848  
mleeming@parkerboiler.com  
www.parkerboiler.com

**Peabody Engineering and Supply Inc.**

Corona, CA  
877-734-3759 • Fax: 951-734-4111  
sales@4peabody.com  
www.4peabody.com

**PermaStore**

Suffolk  
England  
011 44 1379870723  
sales@permaStore.com  
www.permaStore.com

**Pittsburg Tank & Tower Co., Inc.**

Henderson, KY  
270-826-9000 • Fax: 270-827-4417  
pheltsley@watertank.com  
www.watertank.com



**Premier Tech Aqua**

Riviere-du-Loup, QC  
Canada  
800-632-6356 • 418-867-8883 • Fax: 418-862-6642  
pta@premiertech.com  
www.premiertechaqua.com

**Rhino Linings Corporation**

San Deigo, CA  
800-747-6966 • 858-450-0441 • Fax: 858-450-6881  
sales@rhinolinings.com  
www.rhinolinings.com  
**Ad on page 19**

**Superior Tank Co., Inc.**

Rancho Cucamonga, CA  
877-974-4438 • 909-912-0580 • Fax: 909-912-0585  
marketing@superiortank.com  
www.superiortank.com  
**Ad on page 75**

**Thermal Flow Meters**



**Delta M Corporation**

Oak Ridge, TN  
800-922-0083 • 865-483-1569 • Fax: 865-483-1142  
sales@deltamcorp.com  
www.deltamcorp.com

**Emerson / Rosemount**

Shakopee, MN  
800-854-8257 • 952-906-8888  
liquid.csc@emerson.com  
www.rosemount.com



**FCI - Fluid Components International**

San Marcos, CA  
800-854-1993 • 760-744-6950 • Fax: 760-736-6250  
eflow@fluidcomponents.com  
www.fluidcomponents.com

**Sierra Instruments, Inc.**

Monterey, CA  
800-866-0200 • 831-373-0200 • Fax: 831-373-4402  
info@sierrainstruments.com  
www.sierrainstruments.com

**Truck Loading Bins & Silos**

**Schwing Bioset, Inc.**

Somerset, WI  
844-246-7381 • 715-247-3433 • Fax: 715-247-3438  
marketing@schwingbioset.com  
www.schwingbioset.com

**Turbidity Analyzers**

**CHEMetrics, Inc.**

Midland, VA  
800-356-3072 • 540-788-9026 • Fax: 540-788-4856  
sales@chemetrics.com  
www.chemetrics.com



**Emerson / Rosemount**

Shakopee, MN  
800-854-8257 • 952-906-8888  
liquid.csc@emerson.com  
www.rosemount.com



## Endress+Hauser

**Endress+Hauser**  
Greenwood, IN  
888-363-7377 • Fax: 317-535-8498  
info@us.endress.com  
www.us.endress.com

**Hach**  
Loveland, CO  
800-227-4224 • 970-669-3050  
orders@hach.com  
www.hach.com  
**Ad on page 5**

**LaMotte Company**  
Chestertown, MD  
800-344-3100 • 410-778-3100 • Fax: 410-778-6394  
mkt@lamotte.com  
www.lamotte.com

**Van London Co.**  
Houston, TX  
800-522-7920 • 832-456-6641 • Fax: 832-456-6642  
anna@vanlondon.com  
www.vanlondon.com

## Ultrasonic Flow Meters

**AMETEK Drexelbrook**  
Horsham, PA  
215-674-1234 • Fax: 215-674-2731  
drexelbrook.info@ametek.com  
www.drexelbrook.com

**Blue-White Industries, Ltd.**

**Blue-White Industries**  
Huntington Beach, CA  
714-893-8529 • Fax: 714-894-9492  
sales@blue-white.com  
www.blue-white.com  
**Ad on page 2**

**Emerson / Rosemount**  
Shakopee, MN  
800-854-8257 • 952-906-8888  
liquid.csc@emerson.com  
www.rosemount.com

## Endress+Hauser

**Endress+Hauser**  
Greenwood, IN  
888-363-7377 • Fax: 317-535-8498  
info@us.endress.com  
www.us.endress.com

**SIERRA**

**Sierra Instruments, Inc.**  
Monterey, CA  
800-866-0200 • 831-373-0200 • Fax: 831-373-4402  
info@sierrainstruments.com  
www.sierrainstruments.com

**Sure Flow Products, LLC**  
Wixom, MI  
248-380-3569 • Fax: 248-380-3568  
sales@sureflowproducts.com  
www.flowmetersource.com

## UV Disinfection Equipment

**Amiad USA**  
Maoreville, NC  
704-662-3133 • Fax: 704-662-3155  
info@amiadusa.com  
www.amiadusa.com

**Ovivo USA, LLC**  
Austin, TX  
512-834-6000 • Fax: 512-834-6039  
info.us@ovivowater.com  
www.ovivowater.com

**Premier Tech Aqua**  
Riviere-du-Loup, QC  
Canada  
800-632-6356 • 418-867-8883 • Fax: 418-862-6642  
pta@premiertech.com  
www.premiertechaqua.com

**ProMinent Fluid Controls, Inc.**  
Pittsburgh, PA  
412-787-2484 • Fax: 412-787-0704  
sales@prominent.us  
www.prominent.us



**SALCOR, Inc.**  
Fallbrook, CA  
760-731-0745 • Fax: 760-731-2405  
jsruver@aol.com  
**Ad on page 95**

**Sensorex**  
Garden Grove, CA  
800-835-4344 • 714-895-4344  
sales@sensorex.com  
www.sensorex.com

Pure, safe water.   
**Always.**

**UV Pure Technologies, Inc.**  
Toronto, ON  
Canada  
888-407-9997 • 416-208-9884 • Fax: 416-208-5808  
info@uvpure.com  
www.uvpure.com

**Wastewater Depot, LLC**  
Batavia, OH  
513-732-0129 • Fax: 513-735-1485  
info@wastewaterdepot.com  
www.wastewaterdepot.com

## Valves - Actuators/Controls

**Asahi/America, Inc.**  
Lawrence, MA  
800-343-3618 • 781-321-5409 • Fax: 800-787-6861  
asahi@asahi-america.com  
www.asahi-america.com

**Cla-Val**  
Costa Mesa, CA  
800-942-6326 • 949-722-4800 • Fax: 949-574-5703  
info@cla-val.com  
www.cla-val.com

**Flomatic Valves**  
Glens Falls, NY  
800-833-2040 • 518-761-9797 • Fax: 518-761-9798  
flomatic@flomatic.com  
www.flomatic.com

**Flowrox, Inc.**  
Linthicum, MD  
410-636-2250 • Fax: 410-636-9062  
sales-us@flowrox.com  
www.flowrox.com

**Halogen Valve Systems, Inc.**  
Irvine, CA  
949-261-5030 • Fax: 949-261-5033  
info@halogenvaive.com  
www.halogenvaive.com

**Hayward Flow Control**  
Clemmons, NC  
888-429-4635 • Fax: 888-778-8410  
hfcsales@hayward.com  
www.haywardflowcontrol.com  
**Ad on page 15**

**Red Valve Co. / Tidfex Technologies**  
Carnegie, PA  
412-279-0044 • Fax: 412-279-7878  
sales@redvalve.com  
www.redvalve.com  
**Ad on page 35**

**Ronk Electrical**  
Nokomis, IL  
800-221-7665 • 217-563-8333 • Fax: 217-563-8336  
sales@ronkelectrical.com  
www.ronkelectrical.com  
**Ad on page 116**

**Shand & Jurs**  
Hillside, IL  
708-236-6000 • Fax: 708-236-6006  
sales@ljtechnologies.com  
www.ljtechnologies.com  
**Ad on page 29**

**Singer Valve Inc.**  
Surrey, BC  
Canada  
888-764-7858 • 604-594-5404 • Fax: 604-594-8845  
singer@singervalue.com  
www.singervalue.com  
**Ad on page 79**

**ValveUSA**  
786-571-8258  
info@valveusa.com  
www.valveusa.com

## Valves - Air Relief

**Cla-Val**  
Costa Mesa, CA  
800-942-6326 • 949-722-4800 • Fax: 949-574-5703  
info@cla-val.com  
www.cla-val.com

**Flomatic Valves**  
Glens Falls, NY  
800-833-2040 • 518-761-9797 • Fax: 518-761-9798  
flomatic@flomatic.com  
www.flomatic.com

**Hayward Flow Control**  
Clemmons, NC  
888-429-4635 • Fax: 888-778-8410  
hfcsales@hayward.com  
www.haywardflowcontrol.com  
**Ad on page 15**

**Red Valve Co. / Tidfex Technologies**  
Carnegie, PA  
412-279-0044 • Fax: 412-279-7878  
sales@redvalve.com  
www.redvalve.com  
**Ad on page 35**

**Shand & Jurs**  
Hillside, IL  
708-236-6000 • Fax: 708-236-6006  
sales@ljtechnologies.com  
www.ljtechnologies.com  
**Ad on page 29**

**Singer Valve Inc.**  
Surrey, BC  
Canada  
888-764-7858 • 604-594-5404 • Fax: 604-594-8845  
singer@singervalue.com  
www.singervalue.com  
**Ad on page 79**

## Valves - Backflow Prevention/Check/Float

**Asahi/America, Inc.**  
Lawrence, MA  
800-343-3618 • 781-321-5409 • Fax: 800-787-6861  
asahi@asahi-america.com  
www.asahi-america.com

**Cla-Val**  
Costa Mesa, CA  
800-942-6326 • 949-722-4800 • Fax: 949-574-5703  
info@cla-val.com  
www.cla-val.com

**Flomatic Valves**  
Glens Falls, NY  
800-833-2040 • 518-761-9797 • Fax: 518-761-9798  
flomatic@flomatic.com  
www.flomatic.com

**Flowrox, Inc.**  
Linthicum, MD  
410-636-2250 • Fax: 410-636-9062  
sales-us@flowrox.com  
www.flowrox.com

**Hayward Flow Control**  
Clemmons, NC  
888-429-4635 • Fax: 888-778-8410  
hfcsales@hayward.com  
www.haywardflowcontrol.com  
**Ad on page 15**

**PROCO**  
PROCO PRODUCTS, INC.

**Proco Products, Inc.**  
Stockton, CA  
800-344-3246 • 209-943-6088 • Fax: 209-943-0242  
sales@procoproducts.com  
www.procoproducts.com

**Red Valve Co. / Tidfex Technologies**  
Carnegie, PA  
412-279-0044 • Fax: 412-279-7878  
sales@redvalve.com  
www.redvalve.com  
**Ad on page 35**

**Shand & Jurs**

Hillside, IL  
708-236-6000 • Fax: 708-236-6006  
sales@ljtechnologies.com  
www.ljtechnologies.com  
**Ad on page 29**

**Singer Valve Inc.**

Surrey, BC  
Canada  
888-764-7858 • 604-594-5404 • Fax: 604-594-8845  
singer@singervalve.com  
www.singervalve.com  
**Ad on page 79**

**Sure Flow Products, LLC**

Wixom, MI  
248-380-3569 • Fax: 248-380-3568  
sales@sureflowproducts.com  
www.flowmetersource.com

**ValveUSA**

786-571-8258  
info@valveusa.com  
www.valveusa.com

**Zoeller Pump Company**

Louisville, KY  
800-928-7867 • 502-778-2731  
www.zoeller.com

**Valves - Ball/Butterfly**

**Asahi/America, Inc.**

Lawrence, MA  
800-343-3618 • 781-321-5409 • Fax: 800-787-6861  
asahi@asahi-america.com  
www.asahi-america.com

**Flomatic Valves**

Glens Falls, NY  
800-833-2040 • 518-761-9797 • Fax: 518-761-9798  
flomatic@flomatic.com  
www.flomatic.com



**Hayward Flow Control**

Clemmons, NC  
888-429-4635 • Fax: 888-778-8410  
hfcsales@hayward.com  
www.haywardflowcontrol.com  
**Ad on page 15**

**Milwaukee Rubber Products, Inc.**

Menomonee Falls, WI  
800-325-3730 • 262-781-7888 • Fax: 262-781-1742  
sales@milwaukeeerubber.com  
www.milwaukeeerubber.com

**Shand & Jurs**

Hillside, IL  
708-236-6000 • Fax: 708-236-6006  
sales@ljtechnologies.com  
www.ljtechnologies.com  
**Ad on page 29**

**Sunbelt Rentals**

Fort Mill, SC  
800-736-2504  
www.sunbeltrentals.com  
**Ad on page 27**

**Valves - Pinch**

**Red Valve Co. / Tideflex Technologies**

Carnegie, PA  
412-279-0044 • Fax: 412-279-7878  
sales@redvalve.com  
www.redvalve.com  
**Ad on page 35**

**Valves - Plug**

**Flomatic Valves**

Glens Falls, NY  
800-833-2040 • 518-761-9797 • Fax: 518-761-9798  
flomatic@flomatic.com  
www.flomatic.com

**Valves - Pressure Regulating/Solenoid**

**Asahi/America, Inc.**

Lawrence, MA  
800-343-3618 • 781-321-5409 • Fax: 800-787-6861  
asahi@asahi-america.com  
www.asahi-america.com

**Cla-Val**

Costa Mesa, CA  
800-942-6326 • 949-722-4800 • Fax: 949-574-5703  
info@cla-val.com  
www.cla-val.com

**Flomatic Valves**

Glens Falls, NY  
800-833-2040 • 518-761-9797 • Fax: 518-761-9798  
flomatic@flomatic.com  
www.flomatic.com

**Hayward Flow Control**

Clemmons, NC  
888-429-4635 • Fax: 888-778-8410  
hfcsales@hayward.com  
www.haywardflowcontrol.com  
**Ad on page 15**

**Singer Valve Inc.**

Surrey, BC  
Canada  
888-764-7858 • 604-594-5404 • Fax: 604-594-8845  
singer@singervalve.com  
www.singervalve.com  
**Ad on page 79**

**Valves - Telescoping/Gate**

**AMWELL, A Div. of McNish Corp.**

Aurora, IL  
630-898-6900 • Fax: 630-898-1647  
phaizman@amwell-inc.com  
www.amwell-inc.com

**Asahi/America, Inc.**

Lawrence, MA  
800-343-3618 • 781-321-5409 • Fax: 800-787-6861  
asahi@asahi-america.com  
www.asahi-america.com

**Flomatic Valves**

Glens Falls, NY  
800-833-2040 • 518-761-9797 • Fax: 518-761-9798  
flomatic@flomatic.com  
www.flomatic.com

**ValveUSA**

786-571-8258  
info@valveusa.com  
www.valveusa.com

**Water Towers**

**Pittsburg Tank & Tower Co., Inc.**

Henderson, KY  
270-826-9000 • Fax: 270-827-4417  
pheltsley@watertank.com  
www.watertank.com

**Rhino Linings Corporation**

San Diego, CA  
800-747-6966 • 858-450-0441 • Fax: 858-450-6881  
sales@rhinolining.com  
www.rhinolining.com  
**Ad on page 19**

**Water/Wastewater Reuse Systems**

**Alfa Laval Inc.**

Richmond, VA  
866-253-2528  
customerservice.usa@alfalaval.com  
www.alfalaval.us



**Anue Water Technologies, Inc.**

Oceanside, CA  
760-727-2683  
info@anuewater.com  
www.anuewater.com

**Aqua-Aerobic Systems, Inc.**

Loves Park, IL  
800-940-5008 • 815-654-2501 • Fax: 815-654-2508  
solutions@aqua-aerobic.com  
www.aqua-aerobic.com  
**Ad on page 11**

**CEI - Carbon Enterprises Inc.**

Circleville, OH  
800-344-5770 • Fax: 888-204-9656  
info@ceicompanies.com  
www.ceifiltration.com

**GillTrading.com, Inc./WeirWasher, ACS**

Beaverton, OR  
866-447-2496 • 503-628-0197 • Fax: 503-646-9293  
brentgill@gilltrading.com  
www.gilltrading.com

**Headworks International, Inc.**

Houston, TX  
713-647-6667 • Fax: 713-647-0999  
hw@headworksintl.com  
www.headworksintl.com

**Praxair, Inc.**

Burr Ridge, IL  
800-772-9247 • 630-320-4000 • Fax: 630-320-4508  
info@praxair.com  
www.praxair.com/wastewater

**RWL Water**

Golden Valley, MN  
800-879-3677 • 763-746-8400 • Fax: 763-746-8408  
info@rwlwater.com  
www.rwlwater.com



**SALCOR, Inc.**

Fallbrook, CA  
760-731-0745 • Fax: 760-731-2405  
jscraver@aol.com  
**Ad on page 95**

**Smith & Loveless, Inc.**

Lenexa, KS  
800-898-9122 • 913-888-5201  
answers@smithandloveless.com  
www.smithandloveless.com



**UV Pure Technologies, Inc.**

Toronto, ON  
Canada  
888-407-9997 • 416-208-9884 • Fax: 416-208-5808  
info@uvpure.com  
www.uvpure.com

**VAF Filtration Systems**

Arvada, CO  
303-425-4242 • Fax: 303-425-0112  
sales.vaf@evoqua.com  
www.vafusa.com

**Westech Engineering**

Salt Lake City, UT  
801-265-1000 • Fax: 801-265-1080  
info@westech-inc.com  
www.westech-inc.com

**Wireless Ethernet and I/O**



**Weidmüller**  
Richmond, VA  
800-849-9343 • Fax: 804-379-2593  
info@weidmuller.com  
www.weidmuller.com





Order by July 25!

EAT.  
SLEEP.  
SAVE THE  
ENVIRONMENT.  
REPEAT.



Order this custom *TPO* T-Shirt by July 25th!

Only \$18.95 Short-sleeved

\$22.95 long-sleeved

FREE Shipping!

**Tee Style:**  Men  Women    **Tee Color:**  White  Black  
**Tee Size:**  Small  Medium  Large  X-Large  XX-Large  
**Tee Sleeves:**  Short  Long    **Quantity:** \_\_\_\_\_  
**Notes:** \_\_\_\_\_  
**Name:** \_\_\_\_\_  
**Address:** \_\_\_\_\_  
**City:** \_\_\_\_\_ **State:** \_\_\_\_\_ **Zip:** \_\_\_\_\_  
**Phone:** \_\_\_\_\_  
**Credit Card #:** \_\_\_\_\_ **CC Exp:** \_\_\_\_\_ **V-Code:** \_\_\_\_\_

**Mail to:**

COLE Publishing  
PO Box 220  
Three Lakes, WI 54562

**Fax to:** 715-546-3786

Please make checks payable to:  
COLE Publishing

**Order online:**

**shop.tpomag.com**

**NOTE:** Orders ship 2-3 weeks after July 25th closing date.  
Sorry, no foreign orders, shipping to United States only.

Do you have an idea for a tee shirt that *TPO* readers would love? Send your idea to [tees@tpomag.com](mailto:tees@tpomag.com). If we choose your idea you'll get a free 6 pack of tees with your design!



### 1. BLUE-WHITE HYBRID DIAPHRAGM CHEMICAL METERING PUMP

The ProSeries-M MD-3 hybrid diaphragm chemical metering pump from Blue-White has sonic-welded manifolds for added durability and protection from chemical leaks. It provides precision chemical metering for treatment of municipal water and wastewater. It is NSF 61, CE, ETL and NEMA 4X certified, has a 2,000-1 turndown ratio, and provides smooth chemical dosing with no pulsation dampener. With 380 strokes per minute, it provides steady flow. It offers output rates to 58 gph and pressures to 145 psi, with a long service life at high pressures with no pressure regulator needed. PVDF wetted end fittings allow for over 14 inlet and outlet configurations. **714/893-8529; www.blue-white.com**

### 2. RACO EQUIPMENT MONITORING SYSTEM

RACO has introduced Verbatim Connect for its Verbatim alarm autodialer product line, which has been in continuous production since 1989. Verbatim Connect is the latest Industrial Internet of Things (IIoT) innovation in alarm autodialer monitoring. It provides web access to any existing Verbatim monitoring system so users can make smart, timely decisions about all their remote equipment. Verbatim Connect allows users to receive cloud-based alarm notifications by SMS message, email, pager or phone; it monitors a fleet from a single dashboard; and it provides complete alarm history with alarm notification reporting. Upgrading is easy: Existing systems can be retrofitted to offer the newest capabilities. **800/722-6999; www.racom.com/vc**

### 3. PMC ENGINEERING SUBMERSIBLE TRANSDUCER

The VersaLine VL4500 Series submersible transducer from PMC Engineering offers high-integrity construction in a compact design with

a choice of millivolt or 4-20mA configurations for most ranges. Built with a titanium body and diaphragm, this fully welded, compact 0.725-inch-diameter unit can be used for any application where corrosion is a concern. The standard Kevlar-reinforced polyurethane vented cable is molded to the transmitter, providing a high-integrity waterproof assembly. It is available in ranges from 0 to 30 inches, 50-inch WC through 0 to 300 psi with 0.25 and 0.1 percent accuracies. **203/792-8686; www.pmc1.com tpo**

**For FREE information on these products, check the box(es) below:**

- 1. Blue-White ProSeries-M MD-3 hybrid diaphragm chemical metering pump
- 2. RACO Verbatim Connect monitoring system
- 3. PMC Engineering VersaLine VL4500 Series submersible transducer
- Force Flow IBC Tote Scale
- Schneider Electric PowerPact B thermal-magnetic-type circuit breaker
- FREE subscription to TPO magazine**

PRINT NAME: \_\_\_\_\_ TITLE: \_\_\_\_\_

FACILITY NAME: \_\_\_\_\_

MAILING ADDRESS: \_\_\_\_\_

CITY: \_\_\_\_\_ STATE: \_\_\_\_\_ ZIP: \_\_\_\_\_

PHONE: \_\_\_\_\_ CELL PHONE: \_\_\_\_\_

FAX: \_\_\_\_\_ EMAIL: \_\_\_\_\_

**Scan and email to:** nicole.labeau@colepublishing.com

**Fax to:** 715-546-3786

**Mail to:** COLE Publishing Inc., P.O. Box 220, Three Lakes WI 54562

O0517

FREE INFO ON THESE PRODUCTS – RETURN FORM ABOVE



# Every day is Earth Day.™

“I was attracted to wastewater because it offered steady work, a chance to use my background in science and the opportunity to improve the environment and make the community a better place to live.”

Josh Willison  
**An Original Environmentalist**  
 WASTEWATER TREATMENT OPERATOR  
 Franklin County (Mo.) Water & Sewer District



Read about original environmentalists like Josh each month in *Treatment Plant Operator*.

FREE SUBSCRIPTION AT TPOMAG.COM



## wastewater: product spotlight

### Scale allows operators to accurately gauge polymer usage

By Craig Mandli

Increasingly strict federal and state reporting requirements have created a need for water and wastewater plant operators to easily and accurately track chemical feed rates and usages. The **IBC Tote Scale** from **Force Flow** does just that, while providing the assurance that the chemical supply won't unexpectedly run out. Accurately measuring chemical application can also be a big cost saver in the long run.

"Polymer especially is expensive," says Christina Rumbel, marketing coordinator for Force Flow/Halogen. "When adding for dewatering, volumes reach a point where there is little to no more benefit of increasing feed rate further. By cross-checking the amount fed to the solids level achieved, polymer feed can be fine-tuned to maximize effect with minimum expense."

The unit's heavy-duty steel platform is protected with 80-mil-thick Tuf-Coat Environmental Armor. Tuf-Coat is highly resistant to chemicals, abrasion, impact and ultraviolet light degradation, making the IBC Tote Scale ideal for harsh environments. Options include 316 stainless steel and MaxSense high-accuracy models.

The unit creates a highly reliable, non-contacting chemical monitoring system that avoids problems other sensor technologies can face caused by irregular tank shapes, corrosive chemical fumes, fluctuating temperatures and changes in specific gravity. According to Rumbel, users of the product in treatment plant settings have taken notice of that reliability.

"Those using it have told us that the IBC Tote Scale is very durable due to the non-contacting, noninvasive nature into the chemical environment of a weigh scale, as no part of the system is actually inside the vessel," she says. "No technology is more accurate than a scale using electronic load cells."

Using the scale is easy for plant operators. Simply place a chemical tote on the platform and monitoring begins. There is nothing to install inside the tote, making the unit virtually plug-and-play.

"Unlike other sensor technologies, a scale is perfectly suited for monitoring portable vessels since there is no installation on or into the vessel of any kind required," says Rumbel. "Our experience with using our scales to monitor other portable tanks such as 55-gallon drums and smaller carboys made it a straightforward jump to take the same technology and use it for a larger vessel."

Systems can be remotely monitored from SCADA or PLC, and are available with the SOLO G2 digital display or with the advanced Wizard 4000 Chemical Inventory Monitoring System. **800/893-6723; www.forceflow.com**



IBC Tote Scale from Force Flow

## water: product spotlight

### B-frame circuit breaker offers smaller footprint, installation flexibility

By Craig Mandli

Water system operators are constantly on the lookout for ways to add efficiency and reduce overall footprint. The **PowerPact B** thermal-magnetic-type circuit breaker from **Schneider Electric** accomplishes that, offering power protection in a compact size with easy installation.

The breaker supersedes the popular Square D FA circuit breaker used in multiple water and wastewater applications for circuit protection. It has 25 percent more capacity and takes up less space in electrical equipment. Common water applications include control panel disconnects and multi-motor feeder circuit protection in remote pumping panels, in treatment plant motor control center feeder circuit units (otherwise known as "buckets") and inside Square D I-Line power distribution panels.

"Its smaller footprint not only saves space and costs, it is essential when upsizing infrastructure in existing facilities where space is limited," says Ross Marostica, product manager for Schneider Electric. "For example, it is often necessary to upsize pumps, therefore increasing power requirements, but there may not be enough space to replace existing electrical gear to meet the load requirements. This breaker allows you to provide for higher power requirements within existing spaces."

The breaker uses economical, thermal magnetic sensing elements in each of the various one-, two-, three- and four-pole construction types. A wide variety of external mechanical operators for control panel applications complement field-installable electrical accessories that let customers easily configure the product to their specific needs. The Ever-Link creep-compensating lug spring-based power terminal system ensures a lasting connection by mitigating the loosening effects of heat cycling or vibration. EverLink lugs are even offered with optional built-in control wire terminals.

"It was time to give our customers more flexibility," says Marostica about the new circuit breaker. "And with global challenges of counterfeiting, safe electrical infrastructure and support logistics, we were also able to design in features to help eliminate some of these issues."

To make functionality even more convenient, each breaker includes a QR code that provides access to online product information, customer care center contact info, a serial number for tracking, and an embedded anti-counterfeit system.

"The importance of a circuit breaker in the water industry is critical, as it's your last line of defense when everything else does not catch an electrical failure," says Marostica. "It is an unsung hero, waiting a decade to do its job in fractions of a second, all to protect from even greater issues that could arise from an electrical fault. That's why quality and reliability is the most important feature in a new circuit breaker design." **888/778-2733; www.schneider-electric.us**



PowerPact B from Schneider Electric



// The team members are the greatest resource at this plant. They know it. They've been here forever. They do the work. I'm support staff. I coordinate what they do, and the best way for me to do that is to listen to what they have to say."

**Nate Tillis**  
Operations and maintenance supervisor  
Beloit (Wis.) Water Pollution Control  
Treatment Facility

# People.

The greatest natural resource.

**tpomag.com**  
SUBSCRIBE FOR FREE

## industry news

### Endress+Hauser installs high-pressure test rig

Endress+Hauser installed a high-pressure test rig at its U.S. headquarters in Greenwood, Indiana. The rig allows for testing complete instrument assemblies to customer specifications, and provides a 100 percent test indicating a specific instrument can withstand the design process pressure up to 15,000 psi.

### AWWA CEO David LaFrance joins Executive Council of NOAA's NIDIS

The American Water Works Association announced that CEO David LaFrance has joined the Executive Council of the National Integrated Drought Information System for a five-year term. NIDIS is a multiagency partnership led by the U.S. National Oceanic and Atmospheric Administration that provides information and tools to forecast, prepare for and mitigate the effects of drought. **tpo**



Like something?  
Hate something?  
Agree? Disagree?

Share your opinions about *TPO* articles through our Letters to the Editor.

**Send a note to editor@tpomag.com**



# Socially Accepted



facebook.com/TPOmag

twitter.com/TPOmag

plus.google.com

youtube.com/TPOmagazine

linkedin.com/company/treatment-plant-operator-magazine



# FATBOY

**Keep stuff cold. Keep stuff dry. Keep stuff safe.**



**DOUBLE DRAIN PLUG**

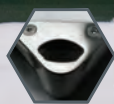

**DUAL STAINLESS LOCKING CORNERS**



**FAST-DRAIN BUTTON**



**ALL STAINLESS OR ALUMINUM HARDWARE**

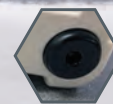

**FRICTION FEET**

**Order yours at [FatboyCoolers.com](http://FatboyCoolers.com). Use promo code **COLE17** to save 10% on your order and get free shipping**



**24 CANS + ICE**



**FLOATS**



**WATERPROOF**



**RUGGED**



**PADDED**



**INSULATED**



**REFLECTIVE**

FREE INFO - SEE ADVERTISER INDEX

## people/awards

The **South Kingstown (Rhode Island) Regional Wastewater Treatment Facility** received a 2016 Wastewater Treatment Regional Operations and Maintenance Excellence Award from the U.S. EPA.

**Kara French** began training as the new operator apprentice at the Three Rivers (Michigan) Wastewater Treatment Plant.

The city of **Holtville, California**, held a ribbon-cutting at its new \$15 million wastewater treatment plant. The U.S. EPA and Border Environment Cooperation Commission along with the North American Development Bank provided more than \$7.2 million in grant funds. The state Clean Water Revolving Fund provided a \$4 million grant and a \$3.8 million low-interest loan.

The **Rural Community Assistance Partnership** received \$1.2 million from the U.S. EPA to improve small, publicly owned wastewater systems.

The **Eustis (Florida) Public Works Department** broke ground on a \$6.85 million upgrade and expansion project at its Eastern Wastewater Treatment Plant, funded in part by a \$2.475 million cost-share grant from the St. Johns River Water Management District.

The **Mount Olivet (Kentucky) Wastewater Treatment Facility** received a \$259,000 USDA Water and Waste Disposal grant to assist upgrades at the facility.

**Bill Breeden** retired as wastewater superintendent for the city of Chillicothe, Missouri. He held the position for 20 years.

The town of **Chazy, New York**, received a \$6,800 state grant to conduct an engineering study on a new disinfection station at its wastewater treatment plant.

The city of **Huron, South Dakota**, received a \$352,930 Community Development Block Grant for improvements to its wastewater system.

**Paul Howard** of Haverhill received the 2016 Massachusetts State Leadership Award from the New England Water Works Association. Howard is senior vice president and co-founder of Tata & Howard, a water, wastewater, stormwater and environmental consulting engineering firm.

The U.S. Water Alliance announced that DC Water CEO and general manager **George Hawkins** and American Water CEO and president **Susan Story** will join its board of directors.

**Randy Mahlman** was named water/wastewater supervisor in West Unity, Ohio.

**David Dockery** retired as the Public Works director in Gainesville, Georgia.

The Belchertown (Massachusetts) Municipal Wastewater Plant received a U.S. EPA award for outstanding operations. The EPA praised treatment plant superintendent Rollin DeWitt and his staff.

The **Beaufort-Jasper Water & Sewer Authority Purrysburg Water Treatment Plant** in South Carolina received the Presidents Award from the Partnership for Safe Water.

## events

### May 3-5

AWWA Arizona Section Annual Conference, Phoenix. Visit [www.azwater.org](http://www.azwater.org).

### May 3-5

AWWA Pacific Northwest Section Annual Conference, Three Rivers Convention Center, Kennewick, Washington. Visit [www.pnws-awwa.org](http://www.pnws-awwa.org).

### May 7-10

AWWA Ontario Section Annual Conference, Scotiabank Convention Centre, Niagara Falls, Ontario. Visit [www.owwa.ca](http://www.owwa.ca).

### May 8-12

New Jersey Water Environment Associations John J. Lagrosa Conference and Exposition, Bally's, Atlantic City. Visit [www.njwea.org](http://www.njwea.org).

### May 9-10

Michigan Water Environment Association Upper Peninsula Wastewater Operators Conference, Island Resort & Casino, Harris. Visit [www.mi-wea.org](http://www.mi-wea.org).

### May 15-16

Greater Water Cities Summit 2017, New York Marriott Marquis. Visit [www.wef.org](http://www.wef.org).

### May 18-19

Water Environment Association of Texas WaterReuse in Texas Conference, El Paso Convention Center. Visit [www.weat.org](http://www.weat.org).

### May 21-24

AWWA West Virginia Annual Conference, Oglebay Resort, Wheeling. Visit [www.wvawwa.org](http://www.wvawwa.org).

### May 21-24

Collection Systems Conference 2017, presented by the Water Environment Federation and the Nebraska Water Environment

### May 22-24

Oklahoma Water Environment Association Technical Conference: Progress In The Heartland, Renaissance Hotel and Convention Center, Oklahoma City. Visit [www.owea.org](http://www.owea.org).

### May 22-25

Central States Water Environment Association Annual Meeting, Intercontinental Riverside (previously Crowne Plaza), St. Paul, Minnesota. Visit [www.cswea.org](http://www.cswea.org).

### May 24-26

AWWA Connecticut Section Annual Conference, Newport, Rhode Island. Visit [www.ctawwa.org](http://www.ctawwa.org).

### May 27-30

AWWA British Columbia Section Annual Conference, Victoria. Visit [www.bcwwa.org](http://www.bcwwa.org).

### May 28-30

British Columbia Water and Waste Association Annual Conference and Trade Show, Victoria. Visit [www.bcwwa.org](http://www.bcwwa.org).

The **South Kingstown (Rhode Island) Regional Wastewater Treatment Facility** received a 2016 Wastewater Treatment Regional Operations and Maintenance Excellence Award from the U.S. EPA.

The **Carpinteria Sanitary District** received both Plant of the Year and Collection System of the Year awards for 2016 from the Tri-Counties Section of the California Water Environment Association.



**Raymond Marshall**, Narragansett Bay Commission executive director, received the 2016 Elizabeth A. Cutone Leadership Award from the New England Water Environment Association.

**Ironhouse Sanitary District** received four awards of excellence from the San Francisco Bay Section of the California Water Environment Association: Plant of the Year, Collection System of the Year, Newsletter of the Year, and Community Engagement and Outreach: Project of the Year.

**Joseph Emminger**, supervisor of the town of Tonawanda, received the New York Water Environment Association Frank E. Van Lare Award for outstanding contributions and commitment of an elected official supporting environmental projects including water resources, wastewater facilities and water quality preservation.

The city of **Duluth** and **MSA Professional Services of Duluth** received an Engineering Excellence Honor Award from the American Council of Engineering Companies of Minnesota for the city's Lift Station No. 8 project.

**Robert J. Kukenberger** received a Life Membership Award from the New York Water Environment Association. Kukenberger, a 40-year member of NYWEA, served as its president in 2008 and then as a national representative to the Water Environment Federation House of Delegates for three years.

State Assemblyman **Steve Englebright** received the 2016 Nelson A. Rockefeller Award from the New York Water Environment Association for contributions to advancing the quality of the water environment.

The **Fort Collins (Colorado) Utilities Water Treatment Facility** received the Presidents Award from the Partnership for Safe Water.

New York City's **Sheldon Avenue Stormwater Management Project** on Staten Island, executed by the Department of Design and Construction on behalf of the Department of Environmental Protection, received an Envision Silver sustainable infrastructure award from the Institute for Sustainable Infrastructure.

The **Colorado Springs Utilities Southern Delivery System Program** received a Mountain States Best Projects Award from Engineering News-Record in the Water/Environment Category.

The **Lake County (Illinois) Department of Utilities** has received a Directors Award from the Partnership for Safe Water for its East Water Treatment Plant in Painesville and West Water Treatment Plant in Willoughby.

**Kyle Pritchett**, wastewater management supervisor in Corsicana, Texas, was promoted to environmental services director. **tpo**



# CLASSIFIED ADVERTISING

## COVERS

**POND & TANK COVERS:** Industrial & Environmental Concepts makes gas-collection covers, odor-control covers, heat-retention covers and anaerobic digester covers. Call 952-829-0731 [www.ieccovers.com](http://www.ieccovers.com) (oBM)

## EDUCATION

RoyCEU.com: We provide continuing education courses for water, wastewater and water distribution system operators. Log onto [www.royceu.com](http://www.royceu.com) and see our approved states and courses. Call 386-574-4307 for details. (oBM)

## PIPELINE REHABILITATION

One trade-in model of Pipe Genie heavy-duty, pipe bursting equipment. Excellent condition, looks new, 30-ton, 100 feet cable, full 2-year warranty. 877-411-7473. (CBM)

## POSITIONS AVAILABLE

The Town of Wartrace, Tennessee is seeking a Water & Utilities Manager to supervise the overall operations of Wartrace Waterworks and Sewer Systems and the Public Works Department. Responsible for proper operation, maintenance, reporting, collection, treatment, distribution and/or disposal of water and wastewater. Four years of experience and Tennessee Grade 1 Water Distribution, Grade 1 Wastewater Treatment and Grade 1 Wastewater Collection Certifications. Valid Tennessee driver's license. Finalist must pass a background check and drug test prior to employment. NOTE: Wartrace is also hiring a water/wastewater operator. Prefer wastewater certifications and must have valid driver's license. Applications for both positions are available online at [www.townofwartrace.com](http://www.townofwartrace.com) or mail resume to Town of Wartrace, P.O. Box 158, Wartrace, TN 37183. (M05)

Submit your classified ad online!  
[www.tpomag.com/classifieds/place\\_ad](http://www.tpomag.com/classifieds/place_ad)



Keeping it GREEN since 1979

[www.colepublishing.com](http://www.colepublishing.com)

tpomag.com May 2017 115

# Connect with us

[Facebook.com/TPOMag](https://www.facebook.com/TPOMag) [Plus.google.com](https://plus.google.com/)  
[Twitter.com/TPOMag](https://twitter.com/TPOMag) [Youtube.com/TPOMagazine](https://www.youtube.com/TPOMagazine)  
[LinkedIn.com/company/treatment-plant-operator-magazine](https://www.linkedin.com/company/treatment-plant-operator-magazine)



**RED METERS**  
The World's Best Non-Nuclear Density Meter

Real-Time. Accurate. Repeatable.  
The New Standard.

Ask Us About Our Free Test Meter Program  
**407.337.0110**  
redmeters.com



**IWA** **OIML** **NIST** **SME**

855.511.PARK

**AquaCat™ SludgeKing™**  
Specially Designed Dewatering Container



**Features**

- Drier Cakes
- Faster Drying Time
- 30% More Filter Area
- No Cake Sticking When Dumping

**Available Package With PolyCat™**  
Just Flocc It!

**Batch Mixing Polymer System**

**Features**

- Ages Polymer
- Skid Mounted
- Includes VortaFlo™ Static Mixer



**PARK PROCESS**

www.ParkProcess.com



**RONK**

Water and Wastewater Solutions  
**1-800-221-7665**  
Ronkelectrical.com



**WATER-REEL**

Redistribute Waste Water with Superior Uniformity



**KIFCO**  
www.kifco.com  
800.452.7017 • sales@kifco.com

**NC RWA**  
TRAINING SUPPORT

Choose North Carolina Rural Water Association for all your water & wastewater training needs!

**www.ncrwa.com**  
**336-731-6963**

**ScreenCO Systems**  
208-790-8770  
www.ScreenCoSystems.com  
sales@screenco.com

**MEGA DUAL SCREEN PORTABLE RECEIVING STATION**

- No Other System Matches Our GPM Capacity
- 40.5 sq. ft. of Screen
- Off-Loads At Up To 1000 GPM
- 6" Offload Through Dual Fan Spreaders

**GRIT ELIMINATOR**

- Removes Grit From Flow Stream
- Keeps Onsite Storage Grit Free

**PROGRESSIVE CAVITY PUMP**

- Geared motor, flanged to pump
- Pin joint sealed with elastomeric boot
- Hardened steel, chrome plating rotor
- Enlarged suction housing
- ANSI connections

**SHAFT DRIVE PUMPS & AGITATORS**

- Move septic and grease waste from underground tanks
- Handles sand grit & slurry type materials
- Great for transferring to land application site
- Mix while dewatering
- Agitate fast, transfer fast, load fast
- Pit depths 3 - 12 ft.

**PHi**  
Pulsed Hydraulics, Inc.

Mix 1,000,000 gallons of water in an Hour

SEE IT WORK, GO TO THIS LINK  
[www.phewater.com/TPOwaterstorage2.htm](http://www.phewater.com/TPOwaterstorage2.htm)

**ACE<sup>17</sup>**  
Booth 1838

**Electrolytic Technologies**

Chlorine gas does not need to be a threat - safely produce chlorine and/or high-strength sodium hypochlorite for water disinfection with Klorigen on-site generation technology!

- Klorigen™ systems produce chlorine gas for safe, on-demand disinfection as it is produced OR combine with co-product sodium hydroxide to produce high quality 12.5-15% sodium hypochlorite. Benefits include:
- Chlorine capacities range from 40 lbs./day to over 20 tons
  - Automated systems require minimal operating manpower
  - Eliminate handling, storage and transportation of chlorine
  - Reduce or eliminate risk management reporting
  - NSF/ANSI Standard 60-compliant NaOCl product
  - Produce disinfectants equivalent to commercially available chemical at a fraction of the cost

**ACE<sup>17</sup>**  
ANNUAL CONFERENCE & EXPOSITION  
JUNE 11-14 | PHILADELPHIA, PA

Electrolytic Technologies LLC will be exhibiting at ACE 2017 in Philadelphia - visit us at Booth 1731 for more information on Klorigen™ on-site generators.

On-site generation for the next generation

For additional information, contact us at:

**Electrolytic Technologies LLC**  
19597 NE 10<sup>th</sup> Avenue, North Miami Beach, FL 33179  
Tel: (305) 655-2755 / Fax: (305) 655-2669  
Email: info@electrolytictech.com  
www.electrolytictech.com

**IndustrialOdorControl.com**  
A Broad and Economical Range of Odor Control Solutions



Pictured: Super Wolverine 8# Unit  
Patent # US 8,273,162

- Manhole Odor Inserts
- Pollution Control Barrels
- Activated Carbon
- Vapor Phase Adsorbors
- Septic Vent Filters
- Custom Solutions

Simple Solutions DISTRIBUTING LLC  
Makers of the Wolverine Brand of Odor Control Solutions

866-NO-STINK (866-667-9465)  
973-846-7817 in NJ

GET EMAIL NEWS ALERTS FOR

**tpo**  
Go to [tpomag.com/alerts](http://tpomag.com/alerts) and get started today!



**The Sludge Judge** Exclusive by **Nasco**

Available in three versions:

- Original Sludge Judge® (3/4" diameter)
- Sludge Judge II (1 1/4" diameter)
- Sludge Judge® Ultra (made of strong polycarbonate)

The Sludge Judge® will take accurate readings of settleable solids in a variety of liquids at any depth – clear 5-ft. plastic tubing that screws together. – for waste water treatment, chemical, and food processing plants, and other facilities.



**Contact Nasco for your FREE Catalog!**

**1.800.558.9595**  
**eNasco.com**

**When Safety is of the Essence**



Meets ANSI & OSHA requirements

Made in the USA

**Emergency Shower Decontamination Booth**

OSHA & ANSI require that emergency shower is to be located within 10 seconds walking time from the hazardous site location. Delivers immediate full body shower. Eye / face wash with positive stay open valves.

**HEMCO** For Prompt Service Call  
Laboratory Planning Solutions 800-779-4362  
**www.HEMCOcorp.com**



**Byo-Gon PX-109®**  
a natural solution to solving the world's water issues.

**We Can Help Solve Yours.**





- Lower BOD and TSS
- Improve clarifier settling
- Eliminates odor
- Reduce FOG
- Increase plant stability

Call Us Today  
**1-888-BYOGON1**  
Email: [info@byogon.com](mailto:info@byogon.com)  
Website: [www.byogon.com](http://www.byogon.com)



**Submersible Pressure Sensor for Liquid Level Indication**

- Compact size & simple "drop in" installation
- Class 1, Division 1 approvals
- Simple field zero adjustment
- Compatible with water, wastewater & many chemicals
- Data from BinView cloud or BinInventory PC software



**Plus!**  
Ultrasonic, float, and magnetostrictive level sensors

**BINMASTER®**  
[www.binmaster.com](http://www.binmaster.com)  
[info@binmaster.com](mailto:info@binmaster.com)  
**800-278-4241**

©2017 BinMaster, 7201 N 98th St., Lincoln, NE 68507

FREE INFO – SEE ADVERTISER INDEX

*Extra! Extra!*

## Want More Stories?

Get more news,  
more information,  
more features with

### Online Exclusives

Exclusive online content for  
*Treatment Plant Operator*

[www.tpomag.com/online\\_exclusives](http://www.tpomag.com/online_exclusives)

TREATMENT PLANT OPERATOR

WATER



## Residual Sulfite Monitor

### Keep Chemical Costs Under Control



The Q46S/66 prevents costly chemical overfeed by controlling the amount of chemical added for process dechlorination. Unique design prevents sensor fouling, which reduces system maintenance.

#### FEATURES

- Gas Phase Sensing - No Contact Between Sensor & Sample
- Internal Sequencing & Relay for Auto Sample Line Cleaning
- Cut Chemical Costs by Eliminating Costly Overfeeds

## Total Chlorine Measurement

### Amperometric Measurement



The Q46H/79S provides a high accuracy measurement at low concentrations of chlorine using an EPA compliant method for compliance monitoring and reporting of Total Chlorine in wastewater effluent.

#### FEATURES

- Unique Gas Sensor Prevents Sensor Fouling
- High Accuracy and Sensitivity Down to PPB
- EPA Compliant for Effluent Reporting

## Toxic & Combustible Gas XMTR

### "Smart Sensor" Technology



Model D12 Gas Transmitters provide the ultimate in application flexibility. Loop-powered or 3-wire models with on-board relays are available, as are both combustible gas and universal toxic gas versions. Digital communication using Hart™ or Modbus™ protocols are available.

#### FEATURES

- Interchangeable "Smart Sensors"
- Internal Data-Logger
- Optional Sensor Daily Auto-Testing

## Total Chlorine Monitor

### Reagent Free



The Q46/79PR direct measuring system does not require the addition of chemical reagents to measure Total Chlorine. This unit is ideal for controlling chlorine addition in wastewater disinfection applications.

#### FEATURES

- Easy installation
- Available in either 90-260 VAC or 12-24 VDC power supply
- Available in Profibus, Modbus, or Ethernet

## Dissolved Oxygen Monitor

### Reliable D.O. measurement Q-Blast



The Q-Blast System with reliable D.O. measurement uses either optical or membraned sensors. The Q-Blast D.O. System is ideal for aeration control systems, resulting in improved process performance and energy savings!

#### FEATURES

- The Q-Blast package includes the monitor and the cleaner air supply which are factory assembled for easy installation
- Choice of using either optical or membraned sensors
- Power Options include Universal 100-240 VAC or 12-24 VDC

## pH/ORP Monitor

### Self-Cleaning pH System



The Q46P/R Monitors enhance the reliability of long-term pH or ORP measurement by providing automatic sensor cleaning. Effective on biological slimes, oily coatings and other non-crystalline buildups, sensor maintenance is greatly reduced.

#### FEATURES

- "Q-Blast" Air-Blast Sensor Cleaning System
- Differential pH and ORP Sensors
- Sealed Reference Prevents Sensor Contamination

Optimize Clarifier & Thickener Performance

# EchoSmart Interface Level Analyzer



## Continuous sludge level measurement supports effective process control

- Prevent sludge wash-out
- Control blanket loss from over-pumping
- Maintain underflow sludge density
- Eliminate doubtful spot hand measurements



www.entechedesign.com



www.analyticaltechnology.com



800-959-0299



# ROBUSCH®

by Gardner Denver

INTRODUCING THE ROBOX ENERGY

## The World's Most Efficient

Rotary Screw Blower Package

The only rotary screw blower package with  
Permanent Magnet Drive Technology

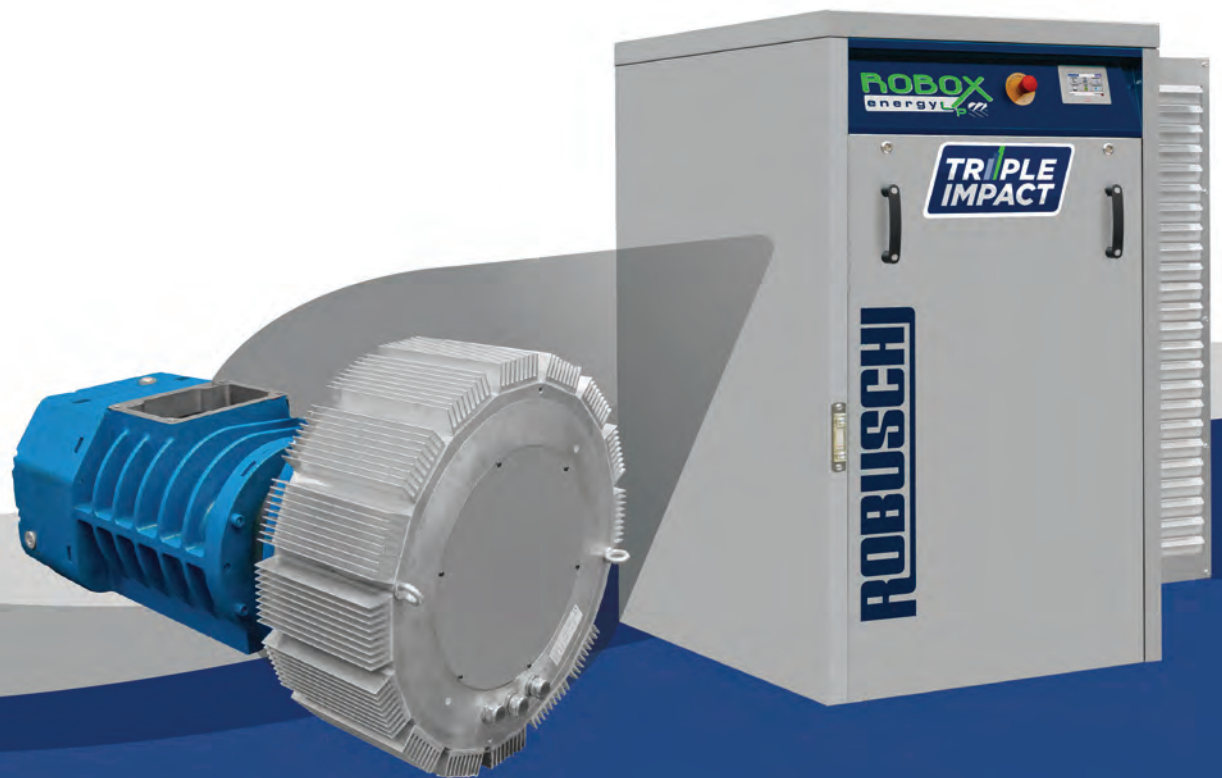

[www.RobuschiUSA.com](http://www.RobuschiUSA.com)

©2017 Gardner Denver. All rights reserved.

**ROBOX**  
energy LP

FREE INFO - SEE ADVERTISER INDEX





★ MANUFACTURED  
IN THE USA



BEFORE



AFTER



# ADD A CONDITIONING PUMP TO THE MIX

The Vaughan Conditioning Pump is a Vaughan Submersible Chopper Pump mounted on a portable stand and fitted with a high-velocity mixing nozzle. The Conditioning Pump recirculates wet wells, chopping and mixing to produce a homogeneous slurry that is more easily pumped out. Floating mats are removed and solids that have accumulated on the floor are re-suspended. Being portable, it can be used in multiple applications at a single job-site, facility or municipality. In one recent project, the Vaughan Chopper Pump paid for itself in 2.5 months. Contact us to see what we can do for you.

## APPLICATIONS

- Lift Station Conditioning
- Basin Conditioning
- Influent Station/Channel Conditioning
- Holding Tank Conditioning
- Digester Cleanout/Homogenization

Experience ease of maintenance with Vaughan Chopper Pumps.

ChopperPumps.com | 360.249.4042 | info@chopperpumps.com



 **Chopper**